



TECHNICAL FILE

ALTIRAIL



Distributed by

Horizontal rail system

ALTIRAIL

PRODUCT ADVANTAGES

The Altirail horizontal rail system is a personal fall protection solution designed to secure high installations, in overhead or where the fall clearance is incompatible with a cable system.

Versatility

Various possibilities of use
(suspended, remote, at the feet,
in front, in overhead, ...)
Can be installed on all types of
structures & roofs

Safety

Rigid system allowing a reduced
height of fall

Design

Careful finishes for
perfect integration
with architectural
constraints

User-friendly

Excellent smooth running
thanks to its mobile runners

Practicity

Possibility of infinite directions
thanks to the switch, which ensures
continuity of movement without
unhooking

Lifespan

Made of stainless
steel for excellent
corrosion resistance

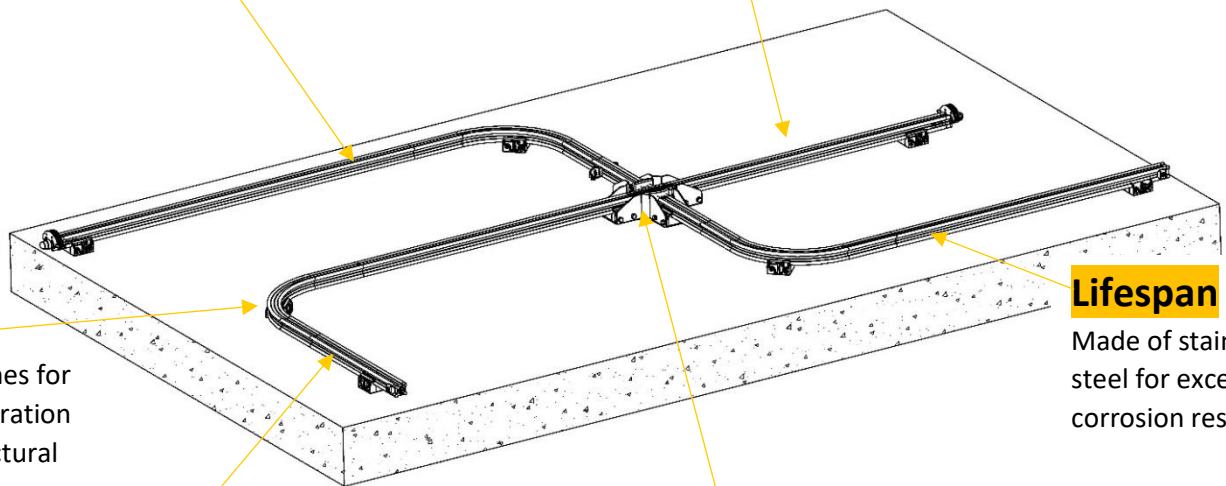



Distributed by

Horizontal rail system

ALTIRAIL

PRESENTATION

The ALTIRAIL solution is a unique way of securing all types of horizontal structures without unhooking.

TECHNICAL CHARACTERISTICS

- Rail material: aluminium 6060 T5
- WVRFC2 and WVRFC3 runners material: aluminium, absorbers and carabiners included
- WVRCBC runner material: Aluminium alloy body
Can be used on inclined structures from 0 to 180°.
Une simple tension exercée vers le bas, bloque automatiquement le chariot dans sa position

CONFORMITY

- Regulation UE 2016/425
- EN 795 D : 2012 + TS16415 :2017
- Certificate of compliance issued by:
DEKRA Testing and Certification GmbH
- Manufacturing follow up by:
APAVE SUDEUROPE SAS (n°0082)
CS60193 – 13322 MARSEILLE CEDEX 16 – France
- Download the declaration of conformity of the WVRCBC via this QR Code



CONFORMITY

It is only when it is technically impossible to implement collective protection that recourse to individual means of protection against falls from height can be considered (Labour Code R4323-61).

Personal protective equipment can also be used as a complement to collective protection. Indeed, the use of this type of protection requires organisational restrictions, such as

- the definition, layout and choice of the type of equipment (lifeline, anchorage point, etc.),
- working with at least two people,
- definition of an emergency response plan,
- implementation and use instructions
- information and training of users
- periodic verifications
- weather conditions.

As a reminder, extract from recommendation R430 - INRS/CNAMTS :

For buildings to be constructed of any kind, the technical provisions intended to facilitate the prevention of falls from height during subsequent work on the building must be provided for at the design stage.

The reason of technical impossibility cannot therefore be accepted, as it is now up to the client to modify his project so that no situation remains that cannot be properly resolved, at least, by the implementation of collective protection.



Distributed by



TRANSLATION

(1) Type Examination Certificate

- (2) No. of the Type Examination Certificate: **ZP/B240/19**
- (3) Product: **Anchor device type D**
Type: **Altirail**
- (4) Manufacturer: **Vertic SAS**
- (5) Address: **691 Chemin des Fontaines, 38190 Bernin, France**
- (6) The design of this product and any acceptable variation thereto are specified in the schedule to this Type Examination Certificate.
- (7) The certification body of DEKRA Testing and Certification GmbH certifies that this product complies with the fundamental requirements of the standard listed under item 8 below. The examination and test results are set out in the report PB 19-305.
- (8) The requirements of the standard are assured by compliance with
DIN EN 795:2012 **DIN CEN/ TS 16415:2017**
- (9) This Type Examination Certificate relates only to the design, examination and tests of the specified product in accordance to the standard list. Further requirements of the Directive apply to the manufacturing process and supply of this personal protective equipment. These are not covered by this certificate.
- (10) This Type Test Certificate is valid until 2024-11-17.

DEKRA Testing and Certification GmbH
Bochum, 2019-11-18

signed: Kilisch
Managing director

We confirm the correctness of the translation from the German original.
In the case of arbitration only the German wording shall be valid and binding.

Managing director



Distributed by



TRANSLATION

- (11) Appendix to
- (12) **Type Examination Certificate ZP/B240/19**
- (13) **13.1 Subject and Type**
Anchor device type D
Type: Altirail

13.2 Description

The anchor device, type: Altirail (figure 1) serves the temporary protection of persons against falls from a height. An extruded aluminium profile, type: R.RAIL3 (figure 2) is used as rigid anchor line, on which the mobile anchor point is running. The user can attach his personal fall protection equipment to that mobile anchor point. The mobile anchor point is available in three different versions, type: R.CF2 (figure 4), type: R.CF3 (figure 5) and type: R.CB2 (figure 6).

The rigid anchor line is attached to the roof, wall or ceiling of the building with suitable end and intermediate brackets, type: R.SUP (figure 3). The maximum field length, i.e. the distance between two brackets, is 4 m. In lateral application, not more than two persons are permitted per 4 m anchor line. For overhead application or when fastened on a roof, up to 4 persons are permitted per 4 m anchor line.

The projection, i.e., the distance from the rail end to the last bracket, must not exceed 200 mm.

The ends of the rigid anchor line are secured against accidental overrunning by firmly bolted end stops. There are two different types of end stops: type: R.EXTF (figure 7) and type: R.BE (figure 8); this one can be opened for installing a mobile anchor point on the rigid anchor line. To install a mobile anchor point on any section of the rigid anchor line, a folding element, type: R.RO (figure 9) can be integrated in the rigid anchor line where needed. Two rigid anchor lines are connected by suitable fastening elements and a connector, type: R.ECL (figure 10).

To move around building corners, the inner curve shown in Figure 11 or the outer curve in figure 12 can be installed. Switches type: R.AIG3D (figure 13) or type: R.AIG4D (figure 14) can be installed where three or four rigid anchor line sections meet.



Figure 1: Application of the anchor device type: Altirail



Distributed by



TRANSLATION



Figure 4: Mobile anchor point, type: R.CF2



Figure 5: Mobile anchor point, type: R.CF3



Figure 6: Mobile anchor point, type: R.CB2



Distributed by



TRANSLATION



Figure 7: End stop, type: R.EXTF



Figure 8: End stop, type: R.BE



Figure 9: Rigid anchor line with folding element for mounting a roller, type: R.RO



Figure 10: Connector, type: R.ECL



Figure 11: Inner curve, type: R.A90E2



Figure 12: Outer curve, type: R.A90S2



Figure 13: 3-way-switch, type: R.AIG3D



Figure 14: 4-way-switch, type: R.AIG4D

(14)

PB 19-305, 2019-11-18





Distributed by



Centre d'Essais de Fontaine
17, Bd Paul Langevin
38600 FONTAINE - France
Tél. +33.(0)4.76.53.52.22

CERTIFICATE OF CONFORMITY N° 19.0196/A

Translation of the certificate n°19.0196/A issued on 12/02/2020 from French to English

1. Applicant

Applicant: M. DUSSERT Sébastien
Manufacturer: VERTIC – 691 Chemins des Fontaines - 38190 BERNIN - France

2. Equipment

Type of equipment: Anchor device type D – EN 795:2012, & TS 16415:2013
Trademark: **VERTIC**
Model: **RCBC + ALTIRAIL**

3. Description

Type D anchorage device, made of:

- An anchorage line in straight rail, in 6060 T5 aluminum, 40.3x11.5,
 - reference R.RAIL_3 of 3 m, reference R.RAIL_1.5 of 1.5 m and reference R.RAIL_1 of 1m
- A rail bent at 90°
 - reference R.A90E2 inward rail, reference R.A90S2 outgoing rail
- Fixation bracket reference R.SUP
- Non-opening trolley in 316L stainless steel, with four guide rollers, including an energy absorber and a connector, reference RCBC.
- Mobile stops, reference R.BE, or fixed stop, reference R.EXTF
- Junction between two rails, reference R.ECL or reference R.RO
- Switch, reference R.AIG3D for 3 directions, reference R.AIG4D for 4 directions
- Maximum cantilevered allowed 20cm

Use floor, wall and underside, with an angle maximal allowed of 15° and for 3 peoples (test according TS 16415:2013). (Description and complete test results in report n°19.0196)

4. Technical reference

Type D anchorage system, has been evaluated according the standard EN 795:2012 and CEN/TS16415:2013 "Personal fall protection equipment - Anchor devices".

5. Condition of use

This type D anchorage system is not a Personal Protection Equipment against fall protection.
This type D anchorage system is intended to be used with Personal Protection Equipments against fall from a height.

6. Conclusion

The type D anchorage system, reference **RCBC + ALTIRAIL**, of trademark **VERTIC**, description and complete test results available in the report n°19.0196, is conforming to the requirements of EN 795:2012 and CEN/TS 16415:2013.

20/11/2020
PPE in charge of the translation

Valérie Bouchoux

This certificate includes one page. No duplicate will be issued

This type of equipment is not a Personal Protective Equipment against falls from height, the present certificate of conformity is not an EC type examination certificate delivered by a notified body

APAVE SUDEUROPE SAS Siège social : 8 rue Jean-Jacques Vernazza - Z.A.C. Saumaty-Séon - BP 193 - 13322 MARSEILLE CEDEX 16
Tél. : 04 96 15 22 60 - Fax : 04 96 15 22 61 - Site Internet : www.apave.com
Société par Actions Simplifiée au Capital de 6 848 544 € - N° SIREN : 518 720 925



Distributed by

Horizontal rail system

ALTIRAIL

CONFORMITE

Altirail system is compatible with:

EN 795 : 2012 + CEN TS 16415 : 2013

Attestation de conformité délivrée par:

Certificate of conformity issued by:

Certificado de conformidad expedido por:

Konformitätserklärung ausgestellt von:

DEKRA EXAM GmbH
Prüflaboratorium für
Bauteilsicherheit
Dinnendahlstraße 9 D-44809
Bochum Allemagne

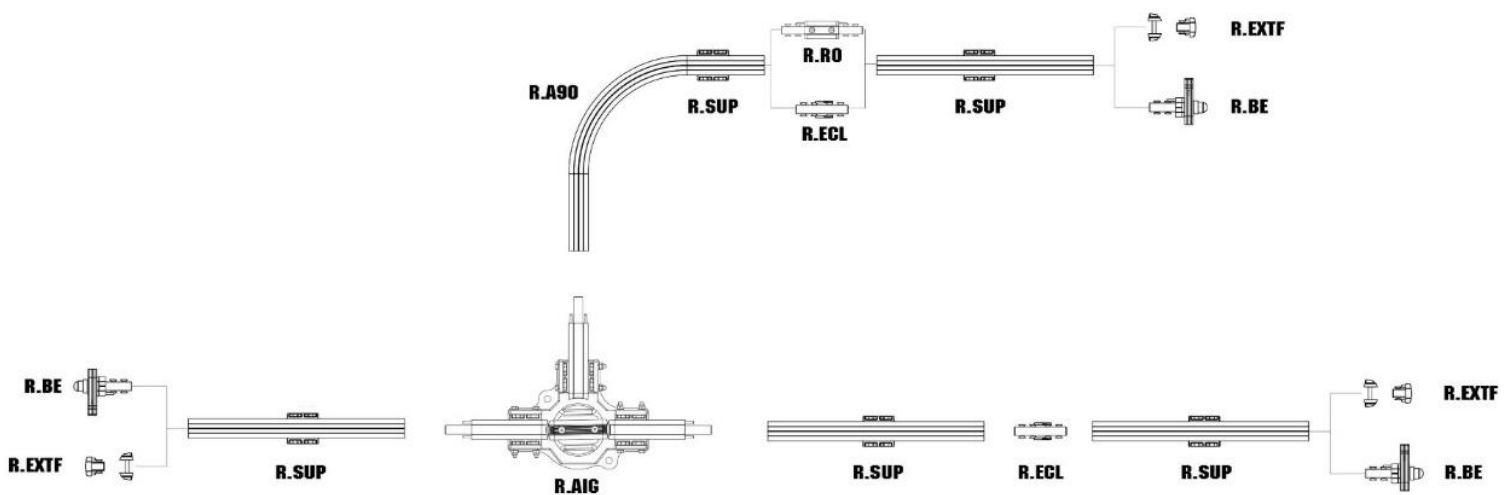



Distributed by

Horizontal rail system

ALTIRAIL

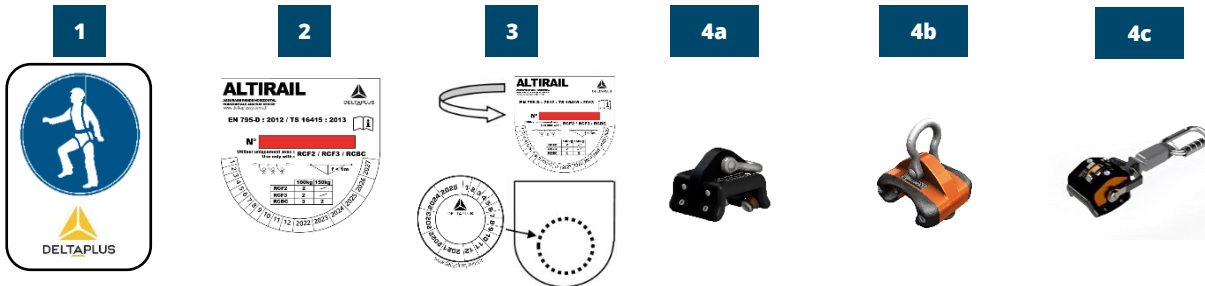

SIGNALISATION & MARKINGS

(1) A sign specifying that personal protective equipment against fall from a height must be worn at all times is placed at the rail's access.

(2) A sign is fixed on the fall arrest rail with the following information:

- System name
- Product description
- Standard
- The system's identification number
- Pictogram: read manual!
- Maximum number of people that can connect simultaneously.
- Manufacturer's name

(3) Badge indicating the periodic inspection's date and the location of the badge on the safety sign.

(4a,b&c) Trolley marking

OPERATING PRINCIPLE

Maximum 2 users between 2 supports.

Maximum 4 m pole distance reduced to 2 m for work in suspension.

The ALTIRAIL system has been designed and certified to be used with the trolley ref. WVRCF2, WVRCF3 and WVRCBC.

Insertion of the trolley on the rail with a retractable end stop WVRBE (1a) or with an entry/exit piece WVRRO (1b).

(2a & 2b) Connection of the fall arrest link (compliant to EN 353-2, EN 355 or EN 360) with a connector compliant to EN 362.

(3) Once connected to the rail, the trolley moves freely along the support, in both directions.

Unhooking won't be necessary to get over the intermediate and angle parts.

(4) Switch use

Warning: before disconnecting of the ALTIRAIL system, the operator must ensure to be safe: area of collective protection or connected to another fall arrest system.

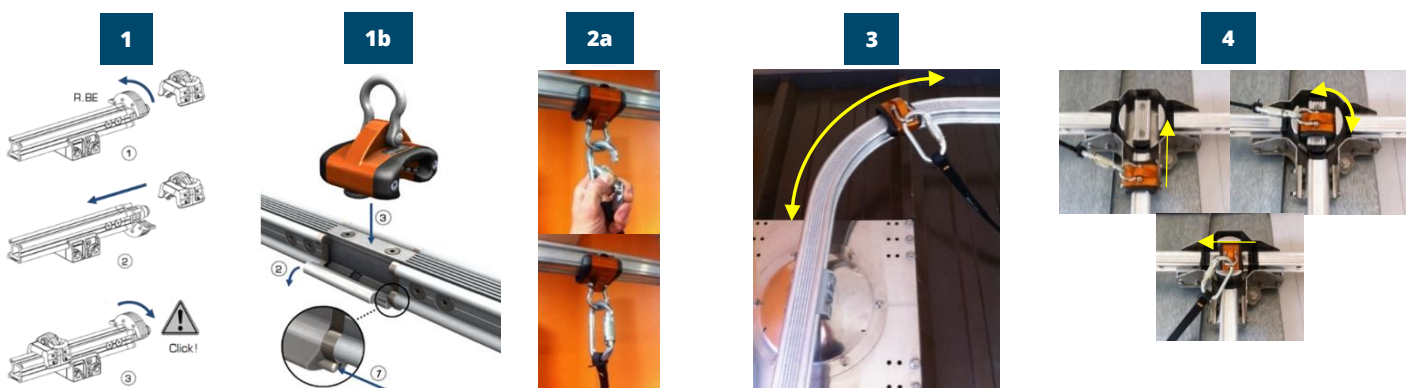



Distributed by

Horizontal rail system

ALTIRAIL

INFORMATION

These instructions are designed for the ALTIRAIL system's users. Before use, they must be read and understood. Should a doubt, a problem in understanding or a problem that is not dealt with in this document arise, please refer to a DELTA PLUS SYSTEMS representative or to DELTA PLUS SYSTEMS's technical services. These instructions must be always at the user's hand. If the product is sold outside of the first country of destination (France) it is crucial for the user's safety that the seller provides the operating instructions, the instructions regarding maintenance, periodic checks and repairs that must be drafted in the language of country where the product is to be used. Any activity at height is dangerous and can cause accidents, severe or fatal injuries. You are liable for the use and for the training to the use of the appropriate equipment. Before using the product, the information contained in these operating instructions must therefore be read and understood. The failure to comply with any of the warnings contained herein may cause severe or fatal injuries. For security reasons, the user must be in good health, and must not be under the influence of medicines, alcohol or drugs. Workers using a piece of personal protective equipment must have been appropriately trained, in compliance with the European directive 89/656, Section II, Article 4, §8.

OPERATING INSTRUCTIONS

TECHNICAL DESCRIPTION

The ALTIRAIL system is a horizontal (max. inclination 15°) rigid anchor support compliant to the EN 795:2012 standard and CEN/TS 16415:2013.

This system is designed to arrest the fall of one or several workers and should not be used for carrying heavy duty.

It is designed for a maximum of 2 users between 2 supports (maximum 4 m pole distance reduced to 2 m for work in suspension).

The ALTIRAIL system must be used with appropriate equipment and limiting the dynamic force exerted on the user to a maximum of 6 kN.

The user should wear an integral safety harness compliant to the EN361 standard.

The user connects to the ALTIRAIL's system with a runner type WVRFC2, WVRFC3 or WVRFCB (one runner per user).

IMPORTANT – PREVENTION:

Before any use

At height, your life depends on the equipment you use. Any doubt regarding the device safety must be reported to the manufacturer and to the installation manager.

The durability of the support should be verified according to the use.

A rescue plan must be implemented to face any emergency that may occur during work.

The ALTIRAIL system must preferably be located above the user.

The stopping distance of the used fall arrest link must be compatible with the clearance available on site. When an adjustable link is used, the worker must optimize its length so as to limit the possible fall height and to reduce the risk of pendulum movement.

Calculation of the Necessary Fall Clearance (NFC):

$$\begin{aligned}
 & \text{Rail deflection (approx.. 1 m)} \\
 & \quad + \text{Lanyard length LL} \\
 & + \text{Lanyard energy absorber deployment DLabs} \\
 & \quad + \text{User height t (usually 1.80m)} \\
 & \quad - \text{Rail height H} \\
 & \quad + \text{Safety distance 1m} \\
 & = \text{Necessary Fall Clearance}
 \end{aligned}$$

Use the ALTIRAIL system with the following PPE against fall from a height:

- EN 355 compliant lanyards with shock absorber
- EN 353-2 mobile rope fall arresters
- EN 360 compliant retractable type fall arresters
- EN 358 and EN 361 compliant full body harnesses and work positioning belts.

CONTROL – CHECKS

Check that the safety rail's operating instructions are put up on the provided sign.

Check that the fall arrest system you have is compliant and compatible with those recommended for the use of the ALTIRAIL system.

Check that the controls and periodic maintenance of the rail system are up to date.



Distributed by

Horizontal rail system

ALTIRAIL

Visually and functionally check the whole rail system. To do this, use the ALTIRAIL system's identification and verification card.

After a fall, the rail must not be used before being controlled and being brought back into conformity by a person authorized by the manufacturer.

SERVICE TIME - DISPOSAL

For the DELTA PLUS SYSTEMS products made of plastics and textile, the maximum service life is 10 years from the date of manufacture. The service life is not limited for metal products.

ATTENTION: an exceptional event can lead to a disposal of the product after only one use (operating type and intensity, operating environment: aggressive environments, marine environment, cutting edges, extreme temperatures, chemicals, etc.)

A product has to be disposed of when:

- It is more than 10 years old and is made of plastics or textile,
- It has been subjected to an important fall (or effort),
- The outcome of the product checks is not satisfactory,
- You doubt this reliability,
- You don't know its complete operating history,
- Its use has become obsolete (legal, standard, technical changes or incompatibility with other devices, etc.).

These products must be destroyed to avoid future use.

SYSTEM RECEIPT AND GUARANTEE

The product guarantee begins at the delivery date of the material or the completion date from DELTA PLUS SYSTEMS. It lasts 10 years subject to the annual maintenance has been performed by DELTA PLUS SYSTEMS or any other company approved by DELTA PLUS SYSTEMS. DELTA PLUS SYSTEMS warrants this product against defects in materials or workmanship. Are excluded from the guarantee: normal wear, oxidation, modifications or repairs, improper storage, poor maintenance, damage due to accidents, negligence, and uses for which this product is not intended.

MAINTENANCE AND OVERHAUL

Any modification or addition to the equipment without the prior written consent of the manufacturer is prohibited.

Any repairs to system components must be carried out in accordance with DELTA PLUS SYSTEMS procedures. If in doubt about the condition of the product, replace it with an original DELTA PLUS SYSTEMS part.

Soiled product should be washed and rinsed with clean water and dried away from direct heat. It must not be brought into contact with corrosive or aggressive materials or stored at extreme temperatures. All chemicals and solvents can alter the resistance of the system components. If there is a risk of contact with these products, please give us the exact name of the chemical components and we will reply after an appropriate study.

It is compulsory to check the condition of the belay systems at least every 12 months by an authorised and competent person in strict compliance with DELTA PLUS SYSTEMS operating procedures. These periodic and regular examinations are necessary because the safety of the user is linked to maintaining the efficiency and resistance of the equipment. The check and the results must be recorded in writing in a maintenance logbook using the identification and verification sheet supplied by DELTA PLUS SYSTEMS.

DELTA PLUS SYSTEMS can also carry out all these maintenance and verification operations.

You can also ensure that your teams are fully familiar with the use of these fall arrest solutions and with the basic concepts involved in working safely at height, by offering them comprehensive, customised training courses run by our training centre.



Delta Plus Training -
691, Chemin des
Fontaines – Cidex 8F -
38190 BERNIN - France



Distributed by

Horizontal rail system

ALTIRAIL

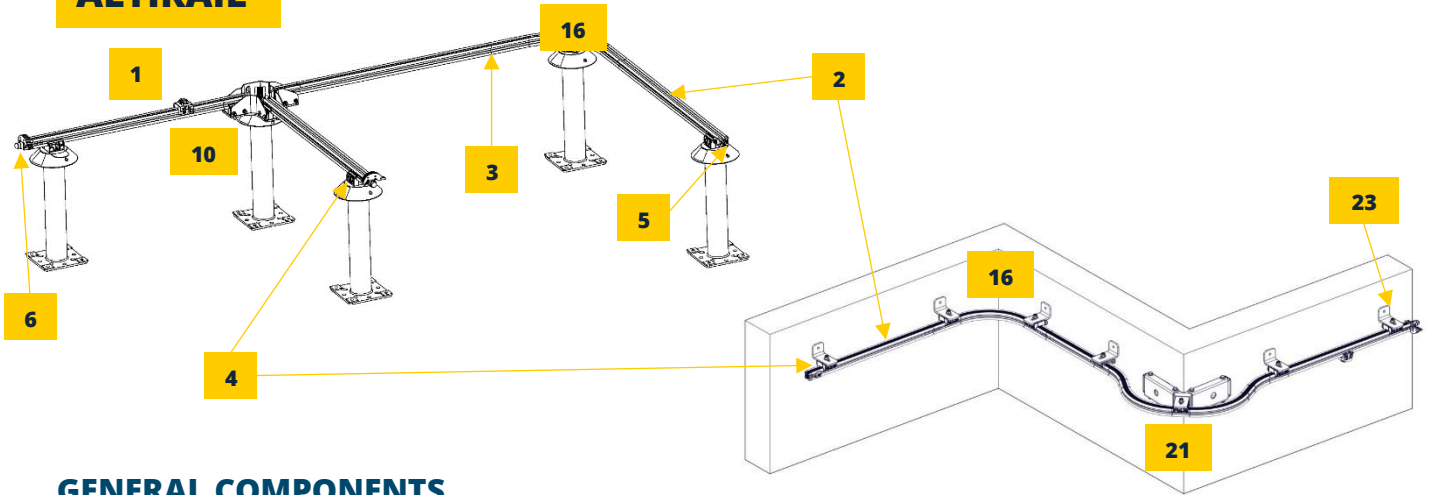

GENERAL COMPONENTS



1

Mobile runners

WVRCF2 / WVRCF3
WVRCF2 : roller runner
WVRCF3 : runner for suspension work



2

Rail

WVLRRAIL
Available in lengths of : 1, 1.5 and 3m. Material: 6060 T5 aluminium. Anodization upon request.

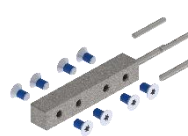

3

Joint

WVRECL
Ensures rail alignment
4 A4 screws pre-coated with threadlocker



4

Rail support

WVRSUP
Max. distance between 2 supports: 4m
2m for suspension work.



5

Fixed end-stop

WVREXTF
Prevents the runner from sliding off the rail - Secured with 3 self-drilling screws (A2).



6

Opening stop

WVRBE
Enables the runner to be inserted into the rail. Automatic closing of the stop.



7

Opening splint

WVRRO
Enables the runner to be inserted at any point on the rail and acts as a jointing plate.



8

Safety pannel

WVRPS
System identification and display of normative information.

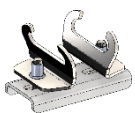

9

Ladder rail support

WVRSUPECH
Adapts to the size and rungs of the ladder



10

Manual switch

WVRAIG3D or 4D
Available in 3 or 4 directions. Allows changes of direction without unhooking.



11

Motorized switch

WVRAIG3DM ou 4DM
Available in 3 or 4 directions. Allows changes of direction without unhooking. Operated by remote control



12

Remote control for switch

WVREM3 ou 10
Used to control motorised switches remotely. Can control up to 9 different points.



Distributed by

Horizontal rail system

ALTIRAIL

GENERAL COMPONENTS



13

90° outside angle
WVRA90S
For lateral runner movement.
250 mm radius. Front
installation.



14

90° inside angle
WVRA90E
For lateral runner movement.
250 mm radius. Façade
installation.



15

90° outside angle
WVRA90S2
For overhead circulation of the
runner. Front or ceiling
installation.



16

90° inside angle
WVRA90E2
For overhead circulation of the
runner. Front or ceiling
installation.



17

Rail support
WVRIAFS
Allows the installation of a rail
angle on the front in a lateral
position.



18

Rail support
WVRIAFS2
Allows the installation of a rail
angle on façade in overhead
position.



19

Rail support
WVRIAFS2SF
Allows the installation of a rail
angle on the ceiling in an
overhead position.



20

Rail support
WVRIAS
Allows installation of a rail angle
on the façade



21

Rail support
WVRIAS2
Allows installation of a rail angle
on the façade



22

Rail support
WVRIAS2SF
Allows installation of a rail angle
on the façade



23

Fixing angle bracket
WVREQG
Material: hot-dip galvanised
steel



24

Fixing angle bracket
WVREQI
Material: 304L stainless steel



25

Anti-return system
WVRANTIR
Used to manage the flow of
runner or to create "storage"
areas to hold them in position.
Do not use as an end stop.



26

Anti-return system
WVRANTIR
Aluminium anti-return system



27

Clear device
WVRDET
Ensures that the runner is
inserted on the rail in the
correct direction of use



28

Drilling tool
WVROUTP
Jig for drilling the rail.





Distributed by

Horizontal rail system

ALTIRAIL

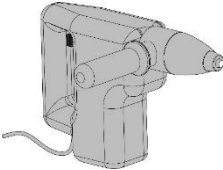
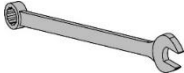
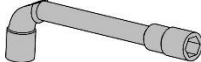
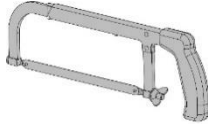
TOOLS & OPERATORS REQUIRED

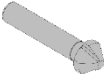
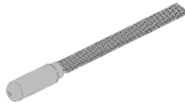
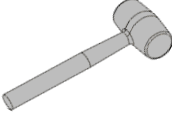
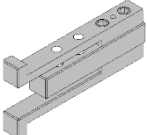
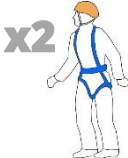
	1		2		3		4
		19		10 - 17 - 19			
	5		6		7		8
5 - 6		Ø 8.5		Ø 16.5			
	9		10		11		
		WVROUTP		x2			

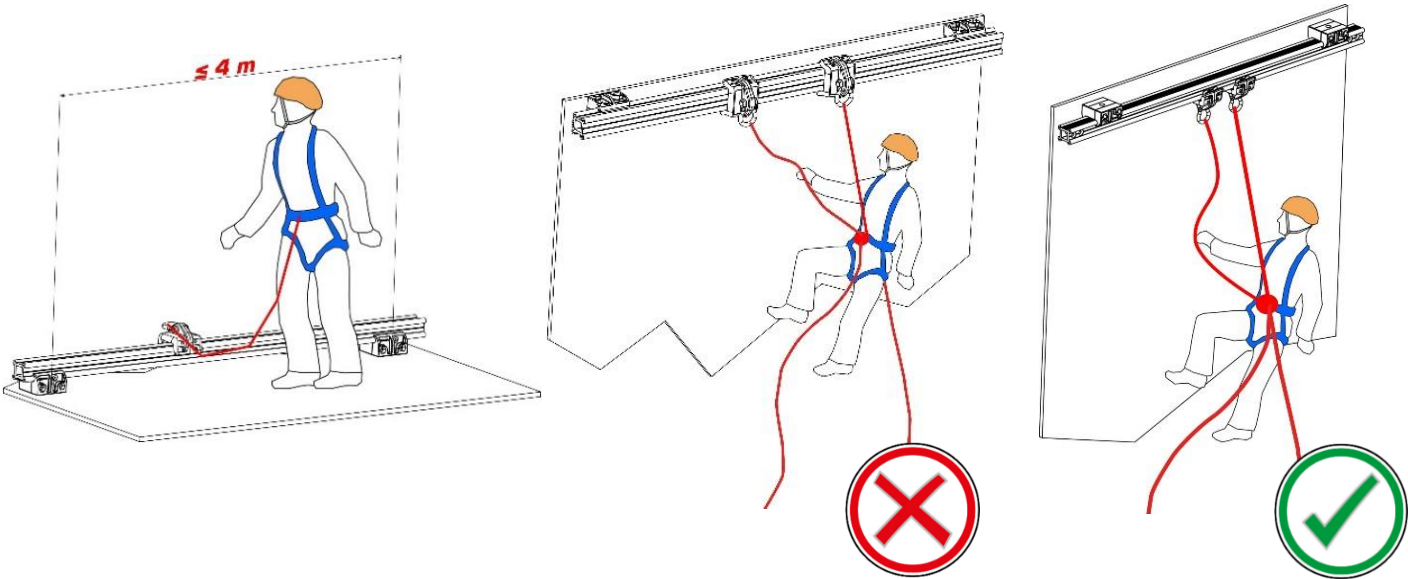



Distributed by

Horizontal rail system

ALTIRAIL

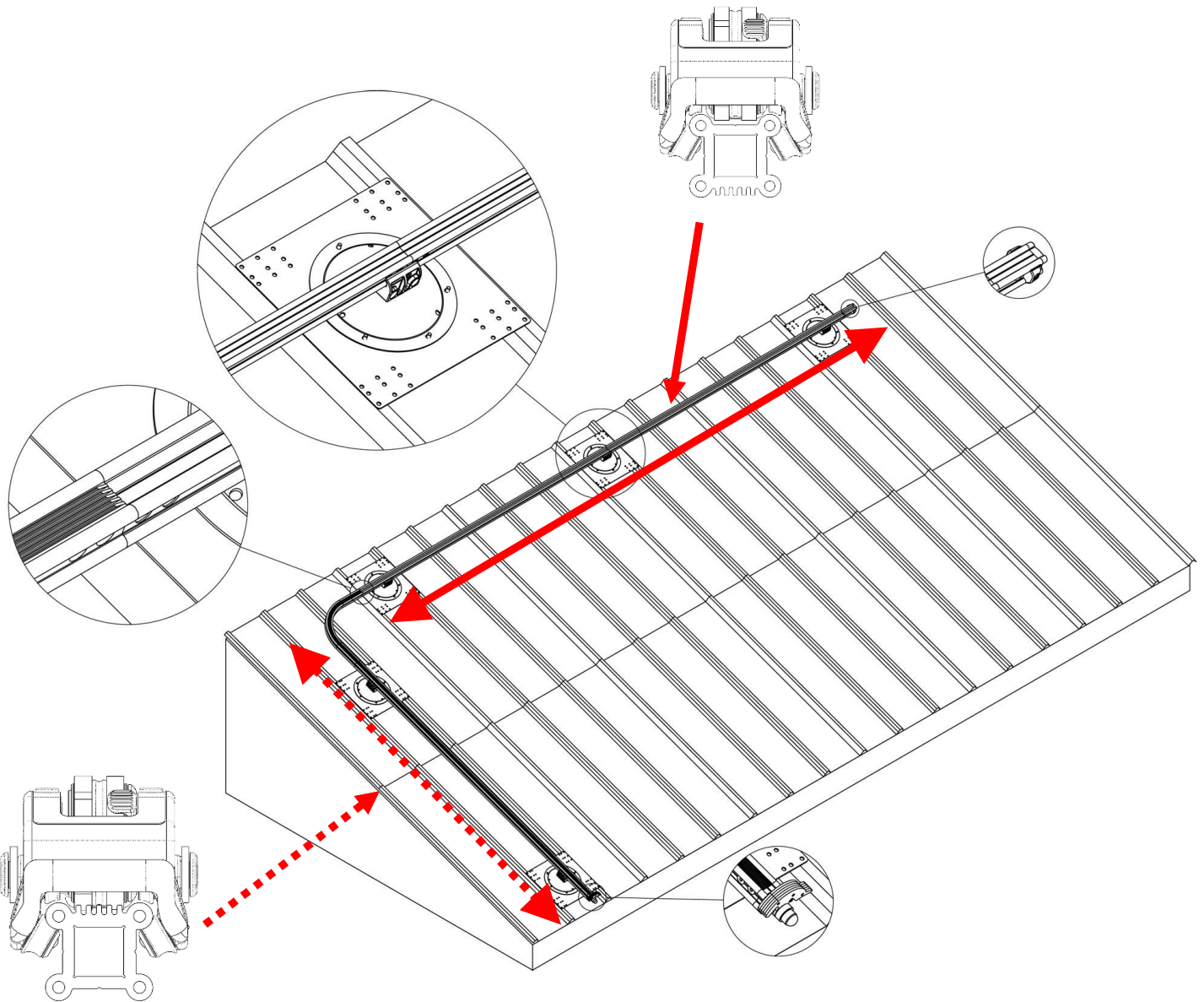



Distributed by

Horizontal rail system

ALTIRAIL

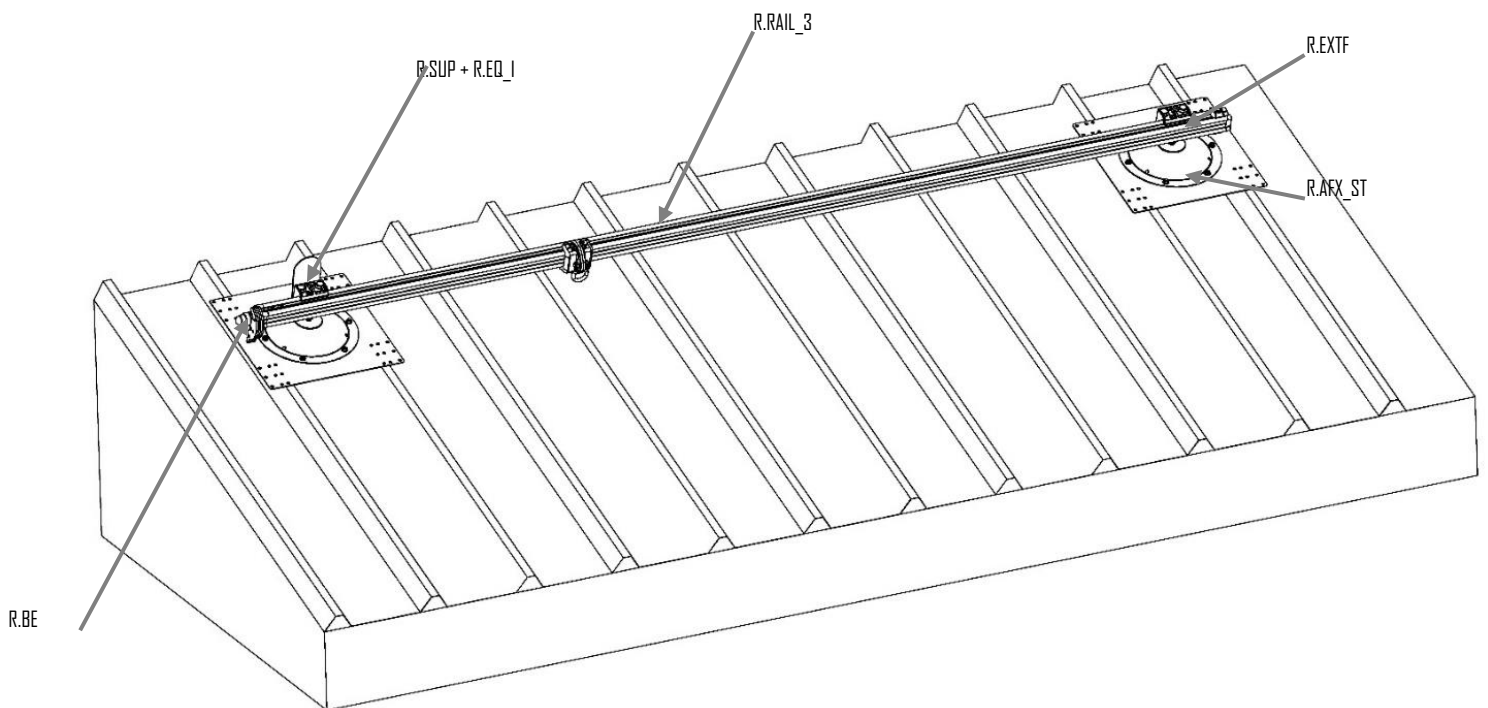
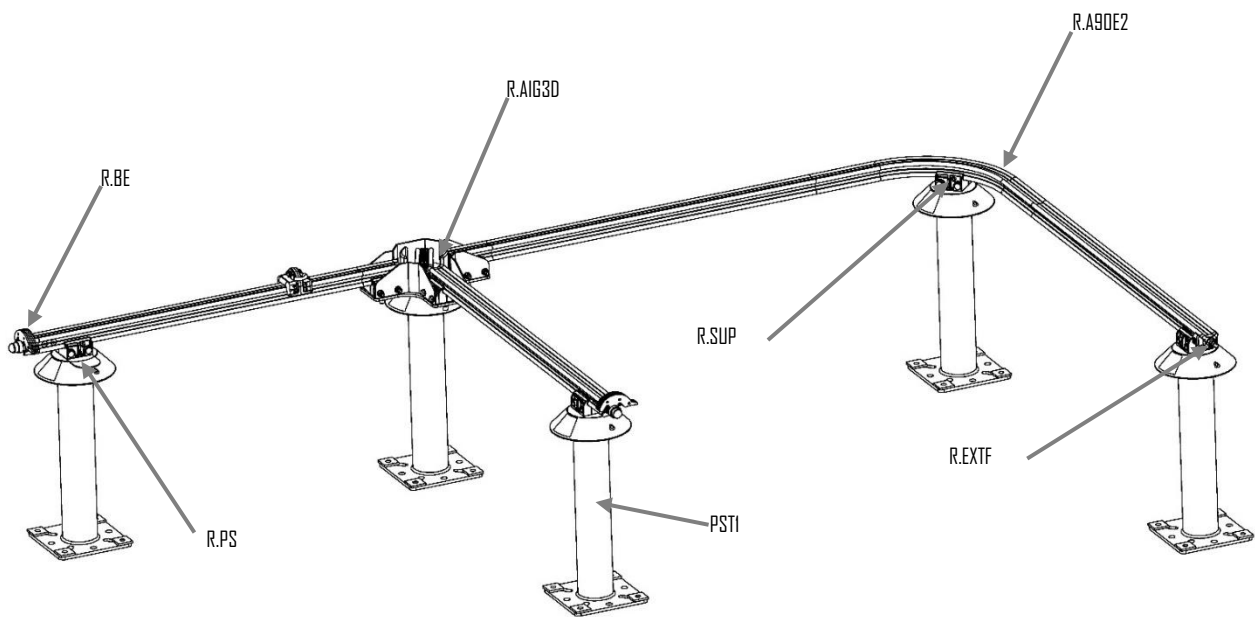



Distributed by

Horizontal rail system

ALTIRAIL

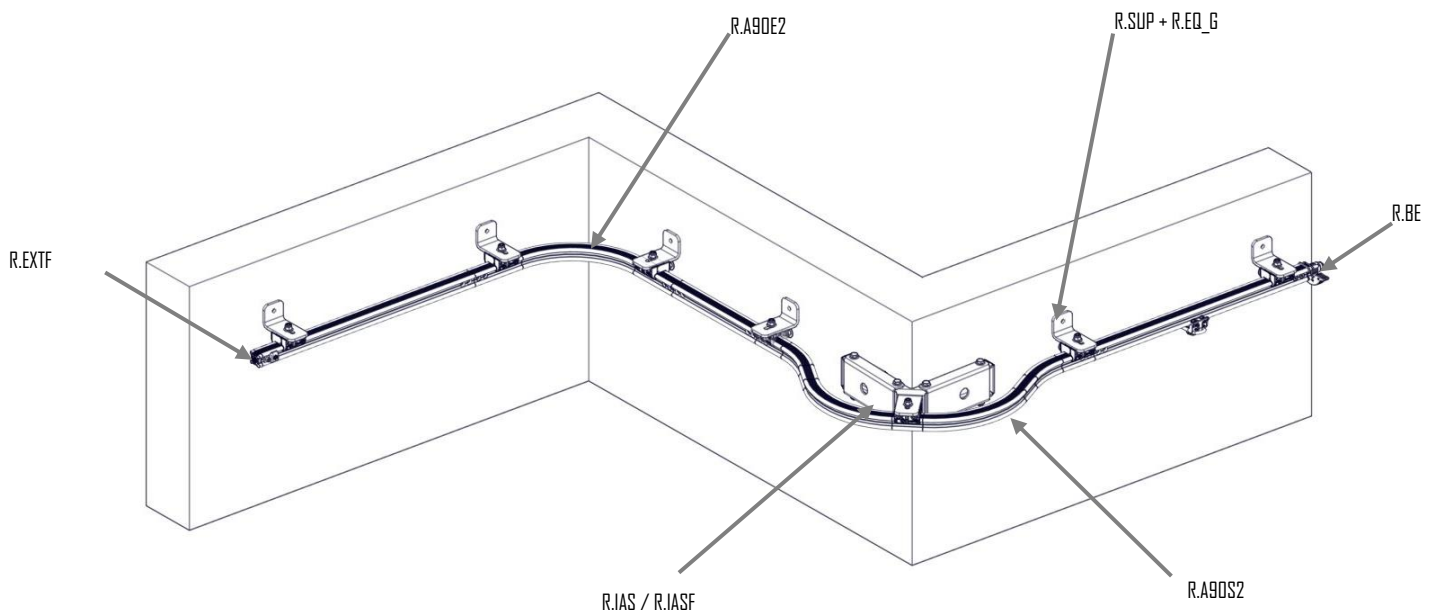
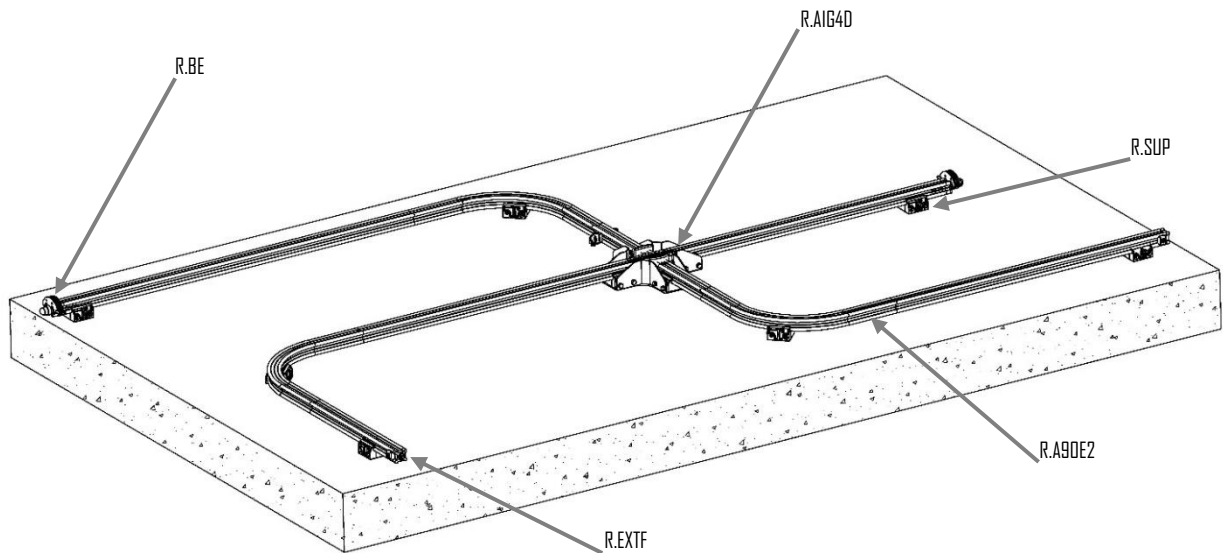



Distributed by

Horizontal rail system

ALTIRAIL

ALTIRAIL FALL ARREST SYSTEM



Product identification	
Manufacturer/Provider:	Delta Plus Systems
System's name:	Fall arrest system ALTIRAIL
Standards:	EN 795 :2012 – CEN/TS16415 :2013

Installation manager's identification			
Installation manager's name and address		Company	
Historical verification			
Date of first use		Purchasing date	
User identity			
Name		Company	

The controller disclaims all liability in case of inaccurate information regarding the periodic check done by the user.

Lifespan/disposal
<p>The products are guaranteed against any material or manufacturing defect for a period of 10 years from the date of delivery for metal parts, the guarantee is 2 years for other parts (textile, plastic, electrical and electronic components, etc.). Interventions under the guarantee shall not have the effect of extending the duration of the guarantee.</p> <p>ATTENTION: an exceptional event can lead to a disposal of the product after only one use (operating type and intensity, operating environment: Aggressive environments, marine environment, cutting edges, extreme temperatures, chemicals, etc.)</p> <p>A product has to be disposed of when:</p> <ul style="list-style-type: none"> - it is more than 10 years old and is made of plastics or textile, - it's been subjected to an important fall (or effort), - The outcome of the product checks is not satisfactory, - You doubt this reliability, - You don't know its complete operating history, - When its use has become obsolete (legal, standard, technical changes or incompatibility with other devices, etc.). <p>These products must be destroyed to avoid future use.</p>

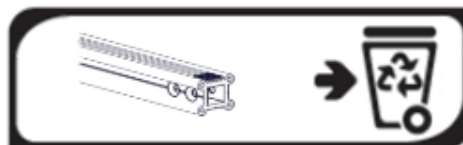



Distributed by

Comments

Correct

To be watched

To be repaired

To be discarded

Visual check of components					
Aluminum rail's general state (signs, deformations, corrosion...)					
Brackets' and supports' state (tightening, corrosion...)					
The rail's mounting parts WRSUP are fixed every 4 m maximum					
For work at height, the rail's mounting parts WRSUP are fixed every 2 m maximum					
Each rail element has at least one support WRSUP					
The rail is horizontal and the teeth are on same side than the support					
The rail supports WRSUP are fixed with chemical anchorage M12 or with M12 bolting					
The joints have no clearance and all the screws are present and tight					
The rail's maximum overhang spans are respected (max. 200 mm)					
The fixing spans for the curved elements are respected					
There is a (fixed or pull-out) stopper at each rail end					
Standard information are indicated on the safety panel					

Functional check of components					
The runners WRCF2, WRCF3 or WRCBC get easily over the joints, supports and curves.					
The runners go correctly onto the rail					
The pull-out stopper works well (automatic home position return...)					

Comments:

Control outcome

Product <u>can</u> remain in use	Product <u>cannot</u> remain in use
----------------------------------	-------------------------------------

Controller's id and stamp

Name		Company	
Date of control		Controller's stamp (company & stamp)	
Date of next control			



Distributed by

Horizontal rail system

ALTIRAIL



MOBILE RUNNER WVRCF2

Product identification	
Manufacturer/Provider:	Delta Plus Systems
System's name:	Mobile runner WVRCF3
Standards:	EN 795 : 2012 Type D

User's identification			
User's name and address		Company	
Historical verification			
Date of first use		Purchasing date	
Manufacturing year		Serial number	

The controller disclaims all liability in case of inaccurate information regarding the periodic check done by the user.

Lifespan/disposal
<p>The products are guaranteed against any material or manufacturing defect for a period of 10 years from the date of delivery for metal parts, the guarantee is 2 years for other parts (textile, plastic, electrical and electronic components, etc.). Interventions under the guarantee shall not have the effect of extending the duration of the guarantee.</p> <p>ATTENTION: an exceptional event can lead to a disposal of the product after only one use (operating type and intensity, operating environment: Aggressive environments, marine environment, cutting edges, extreme temperatures, chemicals, etc.)</p> <p>A product has to be disposed of when:</p> <ul style="list-style-type: none"> - it is more than 10 years old and is made of plastics or textile, - it's been subjected to an important fall (or effort), - The outcome of the product checks is not satisfactory, - You doubt this reliability, - You don't know its complete operating history, - When its use has become obsolete (legal, standard, technical changes or incompatibility with other devices, etc.). <p>These products must be destroyed to avoid future use.</p>



Comments

Correct

To be watched

To be repaired

To be discarded



Distributed by

Visual check of components					
Main body's state (cracks, signs, deformation, wear, corrosion)					
State of the shackle and of its crimped axle (cracks, signs, deformation, wear, corrosion)					
State of the 4 live rollers and of their crimping (cracks, signs, deformation, wear, corrosion)					
State of the 4 friction rollers and of the 2 spacers (cracks, signs, deformation, wear, corrosion)					
State of the 2 axles which diameter equals to 5 mm and of their crimping (deformation, wear, corrosion)					
State of the 2 PU lateral protective devices (cracks, signs, deformation, wear)					
The specification marking containing the standard information is present on the runner					

Functional check of components					
The stainless steel shackle can toggle until 180° (no hard spot)					
The 4 live rollers roll well (no hard spot, fluidity)					
The 4 friction rollers roll well (no hard spot, fluidity)					
The runner rolls smoothly on a straight rail element					
The runner rolls smoothly on a curved rail element					

Comments:	
Control outcome	
<input type="checkbox"/> Product can remain in use	<input type="checkbox"/> Product cannot remain in use

Controller's id and stamp			
Name		Company	
Date of control		Controller's stamp (company & stamp)	
Date of next control			



Distributed by

Horizontal rail system

ALTIRAIL



MOBILE RUNNER WVRCF3

Product identification	
Manufacturer/Provider:	Delta Plus Systems
System's name:	Mobile runner WVRCF3
Standards:	EN 795 : 2012 Type D

User's identification			
User's name and address		Company :	
Historical verification			
Date of first use		Date d'achat :	
Manufacturing year		Numéro de série / Numéro de lot :	

The controller disclaims all liability in case of inaccurate information regarding the periodic check done by the user.

Lifespan/disposal
<p>The products are guaranteed against any material or manufacturing defect for a period of 10 years from the date of delivery for metal parts, the guarantee is 2 years for other parts (textile, plastic, electrical and electronic components, etc.). Interventions under the guarantee shall not have the effect of extending the duration of the guarantee.</p> <p>ATTENTION: an exceptional event can lead to a disposal of the product after only one use (operating type and intensity, operating environment: Aggressive environments, marine environment, cutting edges, extreme temperatures, chemicals, etc.)</p> <p>A product has to be disposed of when:</p> <ul style="list-style-type: none"> - it is more than 10 years old and is made of plastics or textile, - it's been subjected to an important fall (or effort), - The outcome of the product checks is not satisfactory, - You doubt this reliability, - You don't know its complete operating history, - When its use has become obsolete (legal, standard, technical changes or incompatibility with other devices, etc.). <p>These products must be destroyed to avoid future use.</p>



Comments

Correct

To be watched

To be repaired

To be discarded



Distributed by

Visual check of components					
Main body's state (cracks, signs, deformation, wear, corrosion)					
State of the shackle and of its crimped axle (cracks, signs, deformation, wear, corrosion)					
State of the rollers (cracks, signs, deformation, wear, corrosion)					
Condition of the plastic end cap (cracks, deformation)					
Condition of grooves (cracks, marks, deformation, wear, corrosion)					
The specification marking containing the standard information is present on the runner					

Functional check of components					
The stainless steel shackle can toggle until 180° (no hard spot)					
The rollers roll well (no hard spot, fluidity)					
The runner rolls smoothly on a straight rail element					
The runner rolls smoothly on a curved rail element					

Comments:

Control outcome

<input type="checkbox"/> Product can remain in use	<input type="checkbox"/> Product cannot remain in use
---	--

Controller's id and stamp

Name		Company	
Date of control		Controller's stamp (company & stamp)	
Date of next control			