



# FastFit

## Modular System

### Installation

Figure 1



# 1 Contents

|          |   |           |
|----------|---|-----------|
| <b>1</b> | <b>WARNING</b>  | <b>4</b>  |
| <b>2</b> | <b>SPECIFICATION</b>  | <b>4</b>  |
| 2.1      | Description .....   | 4         |
| 2.2      | Material Specification .....                                      | 4         |
| 2.3      | Components .....  | 5         |
| 2.3.1    | Stair Kits 600 .....  | 5         |
| 2.3.2    | Stair Kits 900 .....  | 8         |
| 2.3.3    | Stair Kits 1200.....  | 11        |
| 2.3.4    | Platform Kits .....   | 14        |
| 2.3.5    | Support Kits.....   | 24        |
| 2.3.6    | Cross Brace Kits .....  | 28        |
| 2.3.7    | Components .....  | 29        |
| <b>3</b> | <b>INSTALLATION</b>   | <b>32</b> |
| 3.1      | System Design and Selection .....                                 | 32        |
| 3.1.1    | Location .....  | 32        |
| 3.1.2    | Mesh Support Spacing .....  | 32        |
| 3.1.3    | Mesh Join Location .....  | 32        |
| 3.1.4    | Guardrail and Toeboard Post Spacing .....                         | 33        |
| 3.1.5    | Guardrail, Guardrail Joins, Toeboard and Platform Over Hang ..... | 33        |
| 3.1.6    | Stair Angle .....   | 34        |
| 3.1.7    | Staircase Support.....  | 34        |
| 3.1.8    | Platform Width (Outer Frame) .....                                | 35        |
| 3.1.9    | Platform Height.....  | 35        |
| 3.1.10   | Platform Support Post Spacing .....                               | 36        |
| 3.1.11   | Platform Support .....  | 37        |
| 3.1.12   | Platform Wall Support .....                                       | 37        |
| 3.1.13   | Platform Braces.....  | 38        |
| 3.1.14   | Cross Bracing.....  | 39        |
| 3.1.15   | Platform Connected to Structure .....                             | 39        |
| 3.1.16   | Platform Joins.....   | 40        |
| 3.1.17   | Support Structure Configurations (Stairs and Platforms).....      | 41        |
| 3.1.18   | Support Structure Configurations .....                            | 42        |
| 3.2      | System Requirements .....   | 43        |
| 3.2.1    | Guardrail Height.....   | 43        |
| 3.2.2    | Platform Width.....   | 43        |
| 3.2.3    | Hand Clearance .....  | 44        |
| 3.2.4    | Toeboard .....  | 44        |
| 3.2.5    | Rail Spacing .....  | 45        |
| 3.2.6    | Platform Guardrailing.....  | 46        |
| 3.3      | Fasteners .....   | 47        |
| 3.3.1    | Hex Head Screws .....   | 47        |
| 3.3.2    | T-Bolt .....  | 47        |
| 3.3.3    | Tek Screws .....  | 47        |
| 3.3.4    | Rivets .....  | 47        |
| 3.3.5    | Label.....  | 48        |
| 3.3.6    | SafetyLink Concrete Fastener .....                                | 49        |
| 3.3.7    | Third Party Concrete Fasteners .....                              | 49        |
| <b>4</b> | <b>BRACKETS</b>   | <b>50</b> |
| 4.1      | Stair Bracket (A).....  | 50        |
| 4.2      | Post Bracket (B) .....  | 50        |
| 4.3      | Corner Bracket (C).....   | 51        |

|           |   |           |
|-----------|---|-----------|
| 4.4       | Stair Post Bracket (D&H).....           | 52        |
| 4.5       | Mesh Support Bracket (E).....           | 53        |
| 4.6       | Concrete Foot Bracket (F) .....         | 54        |
| 4.7       | Lateral Brace Bracket (G&H) .....       | 55        |
| 4.8       | Clip Bracket (I).....                   | 56        |
| 4.9       | Platform Splice (J).....                | 57        |
| 4.10      | Stair Bracket Concrete (K).....         | 58        |
| <b>5</b>  | <b>PLATFORMS</b>                        | <b>59</b> |
| 5.1       | Outer Frame (Single Section).....       | 59        |
| 5.2       | Outer Frame (Multiple Sections).....    | 59        |
| 5.3       | Frame Support .....                     | 60        |
| 5.4       | Mesh Support Battens .....              | 60        |
| 5.5       | Platform Frame T and L Junctions .....  | 61        |
| 5.7       | Mesh Fastening.....                     | 62        |
| 5.8       | Mesh Joins .....                        | 62        |
| 5.9       | Mesh Ends .....                         | 63        |
| 5.10      | Platform Single Post.....               | 64        |
| <b>6</b>  | <b>PLATFORM SUPPORTS</b>                | <b>65</b> |
| 6.1       | Posts .....                             | 65        |
| 6.2       | Horizontal Brace.....                   | 66        |
| 6.3       | Diagonal Brace .....                    | 67        |
| 6.4       | Platform Brace.....                     | 67        |
| 6.5       | Concrete Footing .....                  | 68        |
| 6.6       | Sheetmetal Footing.....                 | 68        |
| 6.7       | Sheetmetal Footing Large Platform ..... | 69        |
| 6.8       | Cross Bracing .....                     | 70        |
| 6.9       | Wall Mounted Supports (Concrete) .....  | 70        |
| 6.10      | Wall Mounted Supports (Sheetmetal)..... | 71        |
| <b>7</b>  | <b>STAIRCASES</b>                       | <b>72</b> |
| 7.1       | Staircase Assembly.....                 | 72        |
| 7.2       | Top Tread.....                          | 73        |
| 7.3       | Bottom Tread .....                      | 74        |
| 7.4       | Tread Fixing .....                      | 75        |
| 7.5       | Staircase Single Post .....             | 75        |
| 7.6       | Staircase Mid Support.....              | 76        |
| 7.7       | Staircase to Structure .....            | 77        |
| 7.8       | Ladder to Platform.....                 | 78        |
| <b>8</b>  | <b>GUARDRAILS AND TOE BOARDS</b>        | <b>79</b> |
| 8.1       | Guardrails.....                         | 79        |
| 8.2       | Guardrail Joins.....                    | 79        |
| 8.3       | Rail Corners .....                      | 80        |
| 8.4       | Rail Caps .....                         | 80        |
| 8.5       | Toeboard.....                           | 81        |
| 8.6       | Toeboard Join .....                     | 81        |
| 8.7       | Toeboard Corner .....                   | 81        |
| <b>9</b>  | <b>TOOLS</b>                            | <b>82</b> |
| 9.1       | Middle Rail Spacer .....                | 82        |
| 9.2       | Stair and Platform Jack.....            | 82        |
| <b>10</b> | <b>INSPECTION</b>                       | <b>84</b> |
| 10.1      | Inspection Period.....                  | 84        |

## 1 Warning

- ⚠ *Improper Use, Installation or Maintenance may result in serious injury or death.*
- ⚠ *The structure or anchorage to which SafetyLink products are to be installed shall be assessed by a professional engineer to ensure it has adequate strength to support the product.*
- ⚠ *SafetyLink products shall be installed, used and maintained in accordance with the applicable SafetyLink installation and use manual.*
- ⚠ *SafetyLink's product shall be used in accordance with the current working at height standards, codes of practice, regulation or legislation in the region of use.*
- ⚠ *During installation, use and maintenance, personnel shall not be exposed to a fall hazard.*
- ⚠ *Installation is to be carried out by, or under the supervision of, a competent person.*
- ⚠ *The installer shall complete the applicable SafetyLink online training modules before installing this product.*
- ⚠ *Connection systems used with SafetyLink Anchor, Lifelines and Rigid Rail Systems shall contain a personal energy absorber.*
- ⚠ *Do not carry out any modifications to this product without written permission from SafetyLink.*

## 2 Specification

### 2.1 Description







SafetyLink Modular Systems are a modular access system for permanent installation in a wide variety of scenarios. SafetyLink Modular Systems are designed to and when installed in accordance with this manual are compliant with AS 1657:2018.

### 2.2 Material Specification

| <b>Figure 2</b>    |                                   |
|--------------------|-----------------------------------|
| <b>COMPONENT</b>   | <b>DESCRIPTION</b>                |
| Extrusion Profiles | Aluminium 6000 series             |
| Brackets           | Stainless Steel 316 powder coated |
| Caps               | Polyethylene                      |
| Fasteners          | See Section 3.3                   |

## 2.3 Components

### 2.3.1 Stair Kits 600

| <b>Figure 3</b>   |             |   |             |
|---|-------------|---|-------------|
|    |             |    |             |
| <b>STAIRM.CASE.45.18.600</b>  |             | <b>STAIRM.CASE.45.17.600</b>  |             |
| Height  | 2865-3939mm | Height  | 2706-3720mm |
| Width   | 600mm       | Width   | 600mm       |
| No. of Treads   | 18          | No. of Treads   | 17          |
|   |             |   |             |
| <b>STAIRM.CASE.45.16.600</b>  |             | <b>STAIRM.CASE.45.15.600</b>  |             |
| Height  | 2547-3501mm | Height  | 2388-3282mm |
| Width   | 600mm       | Width   | 600mm       |
| No. of Treads   | 16          | No. of Treads   | 15          |
|  |             |  |             |
| <b>STAIRM.CASE.45.14.600</b>  |             | <b>STAIRM.CASE.45.13.600</b>  |             |
| Height  | 2228-3074mm | Height  | 2070-2845mm |
| Width   | 600mm       | Width   | 600mm       |
| No. of Treads   | 14          | No. of Treads   | 13          |



**STAIRM.CASE.45.12.600**

|               |             |
|---------------|-------------|
| Height        | 1911-2626mm |
| Width         | 600mm       |
| No. of Treads | 12          |



**STAIRM.CASE.45.11.600**

|               |             |
|---------------|-------------|
| Height        | 1752-2407mm |
| Width         | 600mm       |
| No. of Treads | 11          |



**STAIRM.CASE.45.10.600**

|               |             |
|---------------|-------------|
| Height        | 1592-2188mm |
| Width         | 600mm       |
| No. of Treads | 10          |



**STAIRM.CASE.45.09.600**

|               |             |
|---------------|-------------|
| Height        | 1432-1969mm |
| Width         | 600mm       |
| No. of Treads | 9           |



**STAIRM.CASE.45.08.600**

|               |             |
|---------------|-------------|
| Height        | 1273-1751mm |
| Width         | 600mm       |
| No. of Treads | 8           |



**STAIRM.CASE.45.07.600**

|               |             |
|---------------|-------------|
| Height        | 1114-1532mm |
| Width         | 600mm       |
| No. of Treads | 7           |



**STAIRM.CASE.45.06.600**

**STAIRM.CASE.45.05.600**

|               |            |
|---------------|------------|
| Height        | 955-1313mm |
| Width         | 600mm      |
| No. of Treads | 6          |

|               |          |
|---------------|----------|
| Height        | 796-1094 |
| Width         | 600mm    |
| No. of Treads | 5        |



**STAIRM.CASE.45.04.600**

**STAIRM.CASE.45.03.600**

|               |           |
|---------------|-----------|
| Height        | 636-875mm |
| Width         | 600mm     |
| No. of Treads | 4         |

|               |           |
|---------------|-----------|
| Height        | 477-656mm |
| Width         | 600mm     |
| No. of Treads | 3         |









**STAIRM.CASE.45.02.600**

|               |           |
|---------------|-----------|
| Height        | 318-438mm |
| Width         | 600mm     |
| No. of Treads | 2         |

2.3.2 Stair Kits 900

**Figure 4**

|   |             |  |             |
|---|-------------|--|-------------|
|    |             |   |             |
| <b>STAIRM.CASE.45.18.900</b>  |             | <b>STAIRM.CASE.45.17.900</b>   |             |
| Height  | 2865-3939mm | Height   | 2706-3720mm |
| Width   | 900mm       | Width  | 900mm       |
| No. of Treads   | 18          | No. of Treads  | 17          |
|   |             |  |             |
| <b>STAIRM.CASE.45.16.900</b>  |             | <b>STAIRM.CASE.45.15.900</b>   |             |
| Height  | 2547-3501mm | Height   | 2388-3282mm |
| Width   | 900mm       | Width  | 900mm       |
| No. of Treads   | 16          | No. of Treads  | 15          |
|  |             |  |             |
| <b>STAIRM.CASE.45.14.900</b>  |             | <b>STAIRM.CASE.45.13.900</b>   |             |
| Height  | 2228-3074mm | Height   | 2070-2845mm |
| Width   | 900mm       | Width  | 900mm       |
| No. of Treads   | 14          | No. of Treads  | 13          |



**STAIRM.CASE.45.12.900**

|               |             |
|---------------|-------------|
| Height        | 1911-2626mm |
| Width         | 900mm       |
| No. of Treads | 12          |



**STAIRM.CASE.45.11.900**

|               |             |
|---------------|-------------|
| Height        | 1752-2407mm |
| Width         | 900mm       |
| No. of Treads | 11          |



**STAIRM.CASE.45.10.900**

|               |             |
|---------------|-------------|
| Height        | 1592-2188mm |
| Width         | 900mm       |
| No. of Treads | 10          |



**STAIRM.CASE.45.09.900**

|               |             |
|---------------|-------------|
| Height        | 1432-1969mm |
| Width         | 900mm       |
| No. of Treads | 9           |



**STAIRM.CASE.45.08.900**

|               |             |
|---------------|-------------|
| Height        | 1273-1751mm |
| Width         | 900mm       |
| No. of Treads | 8           |



**STAIRM.CASE.45.07.900**

|               |             |
|---------------|-------------|
| Height        | 1114-1532mm |
| Width         | 900mm       |
| No. of Treads | 7           |



**STAIRM.CASE.45.06.900**

|               |            |
|---------------|------------|
| Height        | 955-1313mm |
| Width         | 900mm      |
| No. of Treads | 6          |



**STAIRM.CASE.45.05.900**

|               |          |
|---------------|----------|
| Height        | 796-1094 |
| Width         | 900mm    |
| No. of Treads | 5        |



**STAIRM.CASE.45.04.900**

|               |           |
|---------------|-----------|
| Height        | 636-875mm |
| Width         | 900mm     |
| No. of Treads | 4         |



**STAIRM.CASE.45.03.900**

|               |           |
|---------------|-----------|
| Height        | 477-656mm |
| Width         | 900mm     |
| No. of Treads | 3         |















**STAIRM.CASE.45.02.900**

|               |           |
|---------------|-----------|
| Height        | 318-438mm |
| Width         | 900mm     |
| No. of Treads | 2         |

2.3.3 Stair Kits 1200

**Figure 5**

|   |             |   |             |
|---|-------------|---|-------------|
|    |             |     |             |
| <b>STAIRM.CASE.45.18.1200</b>   |             | <b>STAIRM.CASE.45.17.1200</b>   |             |
| Height  | 2865-3939mm | Height  | 2706-3720mm |
| Width   | 1200mm      | Width   | 1200mm      |
| No. of Treads   | 18          | No. of Treads   | 17          |
|   |             |    |             |
| <b>STAIRM.CASE.45.16.1200</b>   |             | <b>STAIRM.CASE.45.15.1200</b>   |             |
| Height  | 2547-3501mm | Height  | 2388-3282mm |
| Width   | 1200mm      | Width   | 1200mm      |
| No. of Treads   | 16          | No. of Treads   | 15          |
|  |             |  |             |
| <b>STAIRM.CASE.45.14.1200</b>   |             | <b>STAIRM.CASE.45.13.1200</b>   |             |
| Height  | 2228-3074mm | Height  | 2070-2845mm |
| Width   | 1200mm      | Width   | 1200mm      |
| No. of Treads   | 14          | No. of Treads   | 13          |

|   |             |  |             |
|---|-------------|--|-------------|
|    |             |    |             |
| <b>STAIRM.CASE.45.12.1200</b>   |             | <b>STAIRM.CASE.45.11.1200</b>  |             |
| Height  | 1911-2626mm | Height   | 1752-2407mm |
| Width   | 1200mm      | Width  | 1200mm      |
| No. of Treads   | 12          | No. of Treads  | 11          |
|   |             |  |             |
| <b>STAIRM.CASE.45.10.1200</b>   |             | <b>STAIRM.CASE.45.09.1200</b>  |             |
| Height  | 1592-2188mm | Height   | 1432-1969mm |
| Width   | 1200mm      | Width  | 1200mm      |
| No. of Treads   | 10          | No. of Treads  | 9           |
|  |             |  |             |
| <b>STAIRM.CASE.45.08.1200</b>   |             | <b>STAIRM.CASE.45.07.1200</b>  |             |
| Height  | 1273-1751mm | Height   | 1114-1532mm |
| Width   | 1200mm      | Width  | 1200mm      |
| No. of Treads   | 8           | No. of Treads  | 7           |



**STAIRM.CASE.45.06.1200**

|               |            |
|---------------|------------|
| Height        | 955-1313mm |
| Width         | 1200mm     |
| No. of Treads | 6          |



**STAIRM.CASE.45.05.1200**

|               |          |
|---------------|----------|
| Height        | 796-1094 |
| Width         | 1200mm   |
| No. of Treads | 5        |



**STAIRM.CASE.45.04.1200**

|               |           |
|---------------|-----------|
| Height        | 636-875mm |
| Width         | 1200mm    |
| No. of Treads | 4         |



**STAIRM.CASE.45.03.1200**

|               |           |
|---------------|-----------|
| Height        | 477-656mm |
| Width         | 1200mm    |
| No. of Treads | 3         |











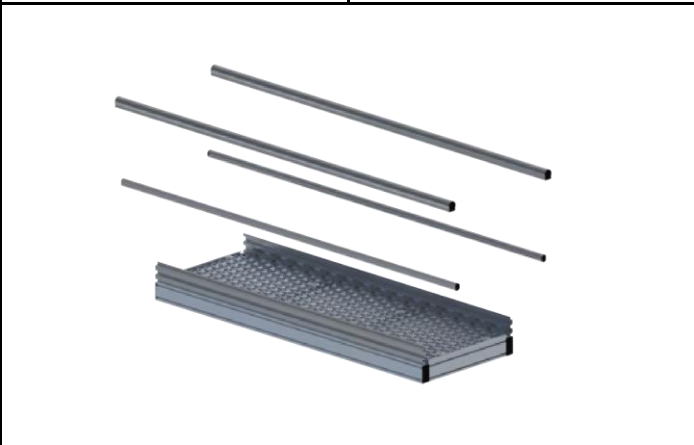

**STAIRM.CASE.45.02.1200**

|               |           |
|---------------|-----------|
| Height        | 318-438mm |
| Width         | 1200mm    |
| No. of Treads | 2         |

2.3.4 Platform Kits

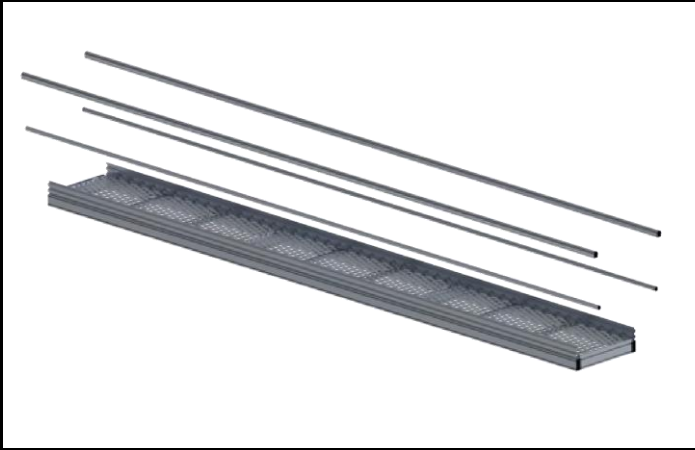
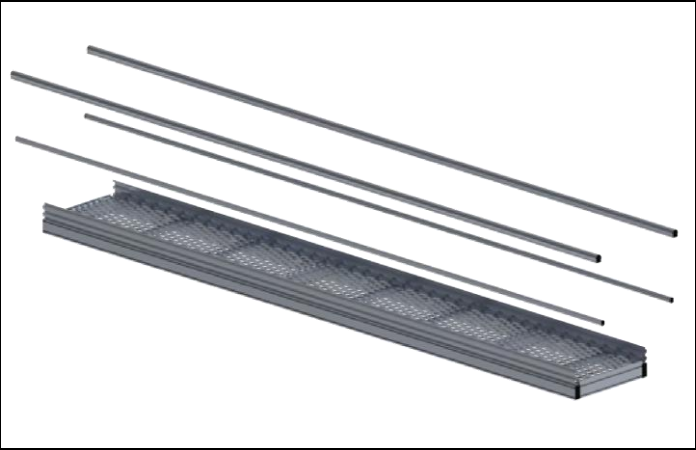
Figure 6

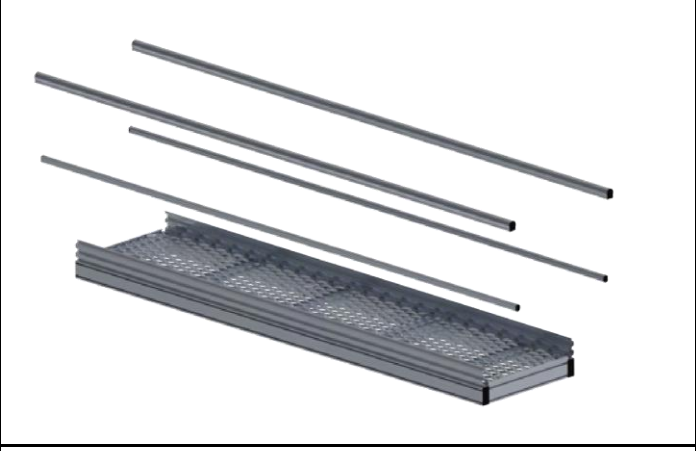
| <b>Figure 6</b>  |             |  |             |
|--|-------------|--|-------------|
|    |             |    |             |
| <b>STAIRM.PLAT.S.686X6000</b>  |             | <b>STAIRM.PLAT.S.686X5000</b>  |             |
| Length   | 6000mm      | Length   | 5000mm      |
| Width  | 686mm       | Width  | 686mm       |
| Mesh   | Small Holes | Mesh   | Small Holes |
|   |             |   |             |
| <b>STAIRM.PLAT.S.686X4000</b>  |             | <b>STAIRM.PLAT.S.686X3000</b>  |             |
| Length   | 4000mm      | Length   | 3000mm      |
| Width  | 686mm       | Width  | 686mm       |
| Mesh   | Small Holes | Mesh   | Small Holes |
|  |             |  |             |
| <b>STAIRM.PLAT.S.686.2000</b>  |             | <b>STAIRM.PLAT.S.686X1000</b>  |             |
| Length   | 2000mm      | Length   | 1000mm      |
| Width  | 686mm       | Width  | 686mm       |
| Mesh   | Small Holes | Mesh   | Small Holes |

|  |         |  |         |
|--|---------|--|---------|
|     |         |     |         |
| <b>STAIRM.PLAT.G.686X6000</b>  |         | <b>STAIRM.PLAT.G.686X5000</b>  |         |
| Length   | 6000mm  | Length   | 5000mm  |
| Width  | 686mm   | Width  | 686mm   |
| Mesh   | Regular | Mesh   | Regular |
|   |         |   |         |
| <b>STAIRM.PLAT.G.686X4000</b>  |         | <b>STAIRM.PLAT.G.686X3000</b>  |         |
| Length   | 4000mm  | Length   | 3000mm  |
| Width  | 686mm   | Width  | 686mm   |
| Mesh   | Regular | Mesh   | Regular |
|  |         |  |         |
| <b>STAIRM.PLAT.G.686X2000</b>  |         | <b>STAIRM.PLAT.G.686X1000</b>  |         |
| Length   | 2000mm  | Length   | 1000mm  |
| Width  | 686mm   | Width  | 686mm   |
| Mesh   | Regular | Mesh   | Regular |



**STAIRM.PLAT.S.1250X6000**

|        |             |
|--------|-------------|
| Length | 6000mm      |
| Width  | 1250mm      |
| Mesh   | Small Holes |



**STAIRM.PLAT.S.1250X5000**

|        |             |
|--------|-------------|
| Length | 5000mm      |
| Width  | 1250mm      |
| Mesh   | Small Holes |



**STAIRM.PLAT.S.1250X4000**

|        |             |
|--------|-------------|
| Length | 4000mm      |
| Width  | 1250mm      |
| Mesh   | Small Holes |



**STAIRM.PLAT.S.1250X3000**

|        |             |
|--------|-------------|
| Length | 3000mm      |
| Width  | 1250mm      |
| Mesh   | Small Holes |



**STAIRM.PLAT.S.1250.2000**

|        |             |
|--------|-------------|
| Length | 2000mm      |
| Width  | 1250mm      |
| Mesh   | Small Holes |



**STAIRM.PLAT.S.1250X1000**

|        |             |
|--------|-------------|
| Length | 1000mm      |
| Width  | 1250mm      |
| Mesh   | Small Holes |



**STAIRM.PLAT.G.1250X6000**

**STAIRM.PLAT.G.1250X5000**

|        |         |
|--------|---------|
| Length | 6000mm  |
| Width  | 1250mm  |
| Mesh   | Regular |

|        |         |
|--------|---------|
| Length | 5000mm  |
| Width  | 1250mm  |
| Mesh   | Regular |



**STAIRM.PLAT.G.1250X4000**

**STAIRM.PLAT.G.1250X3000**

|        |         |
|--------|---------|
| Length | 4000mm  |
| Width  | 1250mm  |
| Mesh   | Regular |

|        |         |
|--------|---------|
| Length | 3000mm  |
| Width  | 1250mm  |
| Mesh   | Regular |



**STAIRM.PLAT.G.1250X2000**

**STAIRM.PLAT.G.1250X1000**

|        |         |
|--------|---------|
| Length | 2000mm  |
| Width  | 1250mm  |
| Mesh   | Regular |

|        |         |
|--------|---------|
| Length | 1000mm  |
| Width  | 1250mm  |
| Mesh   | Regular |



**STAIRM.PLAT.S.1850X6000**

**STAIRM.PLAT.S.1850X5000**

|        |             |        |             |
|--------|-------------|--------|-------------|
| Length | 6000mm      | Length | 5000mm      |
| Width  | 1850mm      | Width  | 1850mm      |
| Mesh   | Small Holes | Mesh   | Small Holes |



**STAIRM.PLAT.S.1850X4000**

**STAIRM.PLAT.S.1850X3000**

|        |             |        |             |
|--------|-------------|--------|-------------|
| Length | 4000mm      | Length | 3000mm      |
| Width  | 1850mm      | Width  | 1850mm      |
| Mesh   | Small Holes | Mesh   | Small Holes |



**STAIRM.PLAT.S.1850.2000**

**STAIRM.PLAT.S.1850X1000**

|        |             |        |             |
|--------|-------------|--------|-------------|
| Length | 2000mm      | Length | 1000mm      |
| Width  | 1850mm      | Width  | 1850mm      |
| Mesh   | Small Holes | Mesh   | Small Holes |

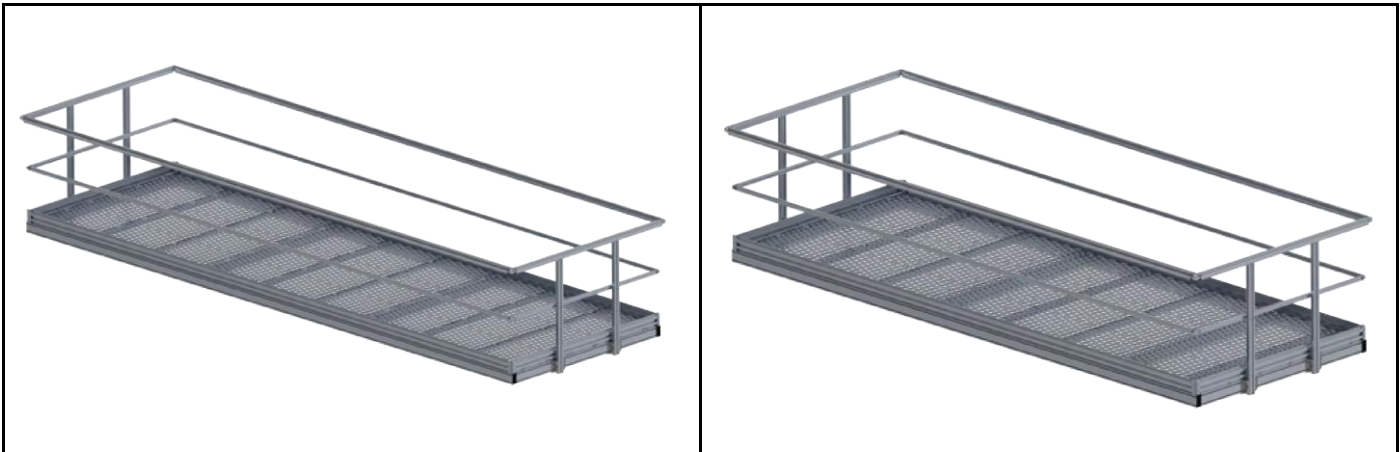

|                                |         |                                |         |
|--------------------------------|---------|--------------------------------|---------|
| <b>STAIRM.PLAT.G.1850X6000</b> |         | <b>STAIRM.PLAT.G.1850X5000</b> |         |
| Length                         | 6000mm  | Length                         | 5000mm  |
| Width                          | 1850mm  | Width                          | 1850mm  |
| Mesh                           | Regular | Mesh                           | Regular |



|                                |         |                                |         |
|--------------------------------|---------|--------------------------------|---------|
| <b>STAIRM.PLAT.G.1850X4000</b> |         | <b>STAIRM.PLAT.G.1850X3000</b> |         |
| Length                         | 4000mm  | Length                         | 3000mm  |
| Width                          | 1850mm  | Width                          | 1850mm  |
| Mesh                           | Regular | Mesh                           | Regular |



|                                |         |                                |         |
|--------------------------------|---------|--------------------------------|---------|
| <b>STAIRM.PLAT.G.1850X2000</b> |         | <b>STAIRM.PLAT.G.1850X1000</b> |         |
| Length                         | 2000mm  | Length                         | 1000mm  |
| Width                          | 1850mm  | Width                          | 1850mm  |
| Mesh                           | Regular | Mesh                           | Regular |

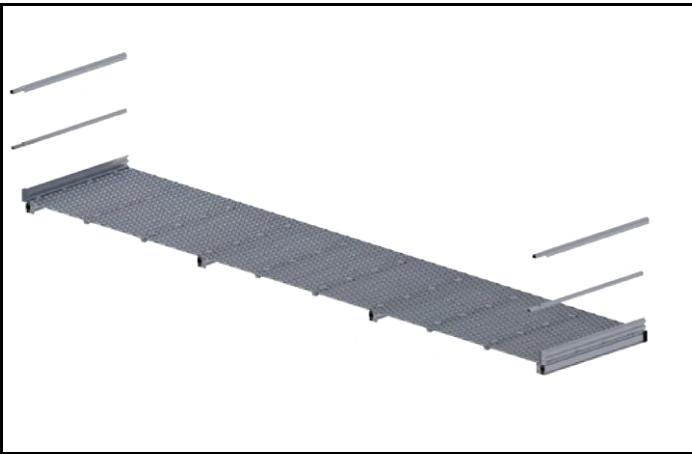

**STAIRM.PLAT.REP.S.1250X6000**

|        |             |
|--------|-------------|
| Length | 6000mm      |
| Width  | 1200mm      |
| Mesh   | Small Holes |

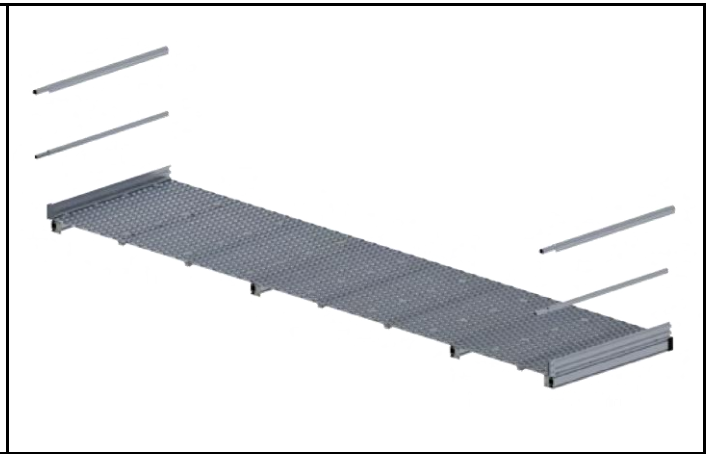

**STAIRM.PLAT.REP.S.1250X5000**

|        |             |
|--------|-------------|
| Length | 5000mm      |
| Width  | 1200mm      |
| Mesh   | Small Holes |

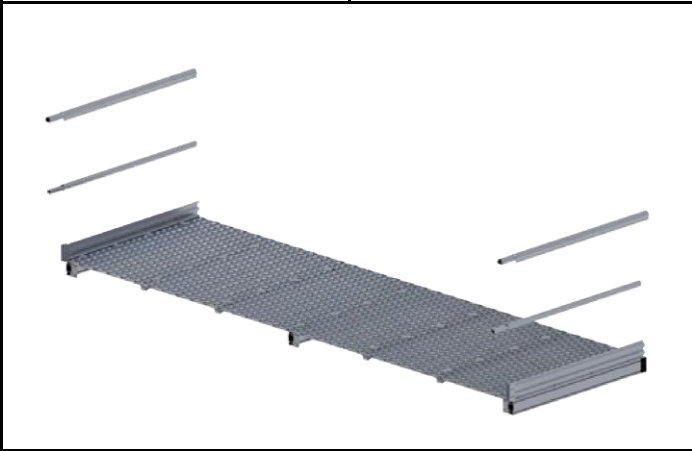

**STAIRM.PLAT.REP.S.1250X4000**

|        |             |
|--------|-------------|
| Length | 4000mm      |
| Width  | 1200mm      |
| Mesh   | Small Holes |



**STAIRM.PLAT.REP.S.1250X3000**

|        |             |
|--------|-------------|
| Length | 3000mm      |
| Width  | 1200mm      |
| Mesh   | Small Holes |





**STAIRM.PLAT.REP.S.1250.2000**



|        |             |
|--------|-------------|
| Length | 2000mm      |
| Width  | 1200mm      |
| Mesh   | Small Holes |

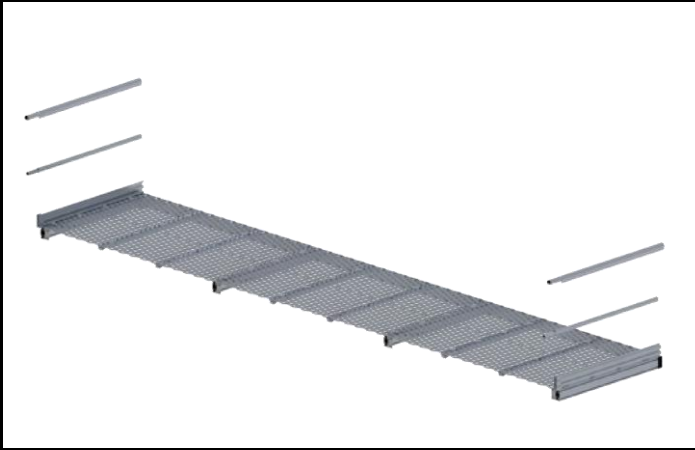
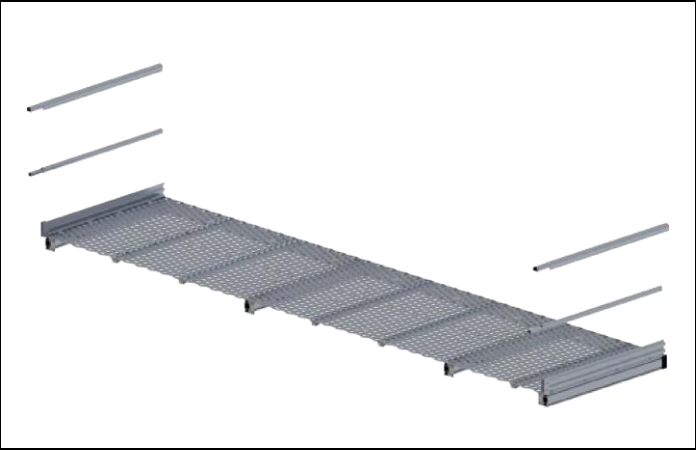
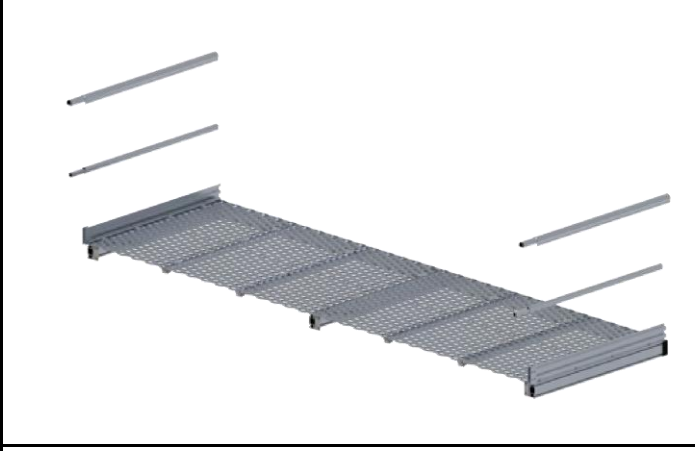
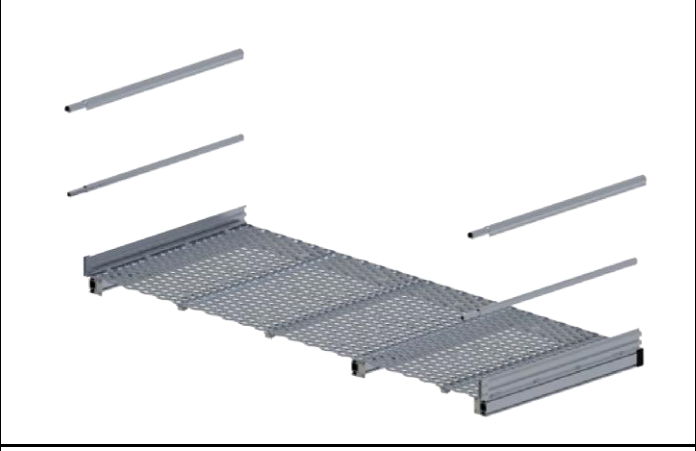
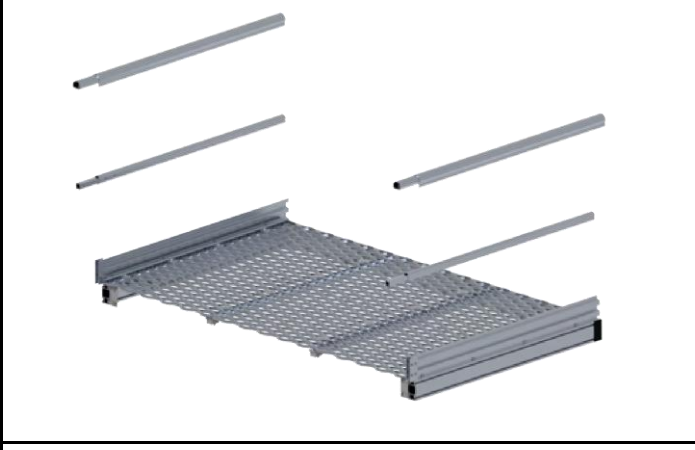

**STAIRM.PLAT.REP.S.1250X1000**

|        |             |
|--------|-------------|
| Length | 1000mm      |
| Width  | 1200mm      |
| Mesh   | Small Holes |

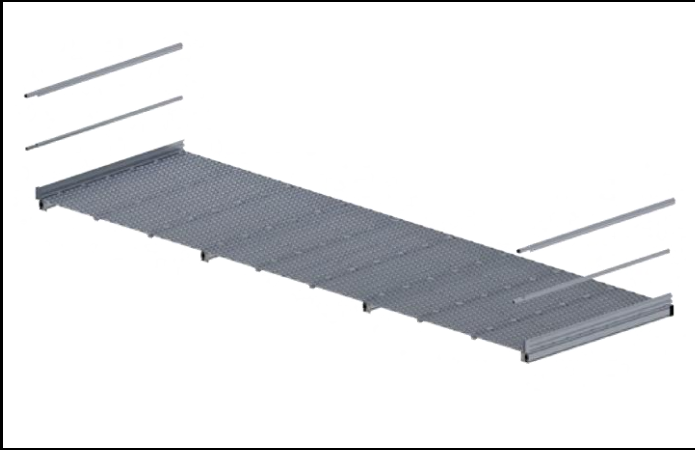
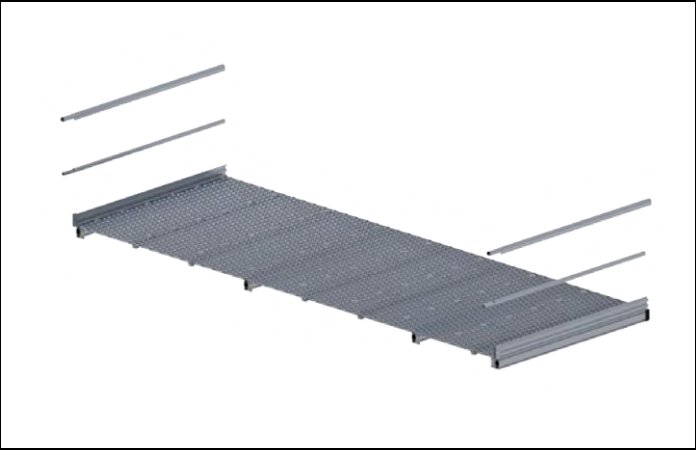
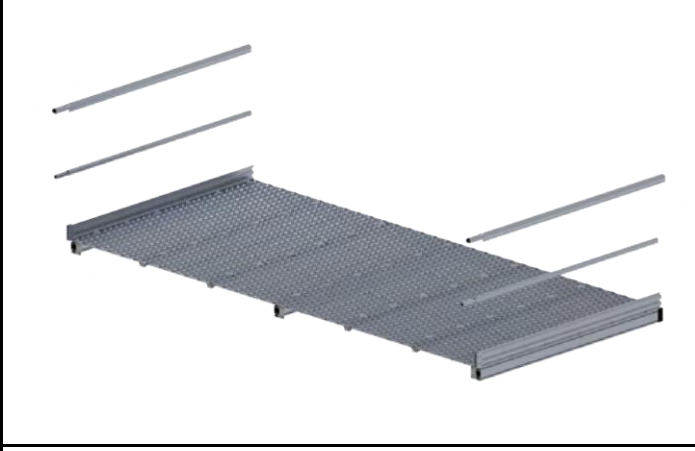
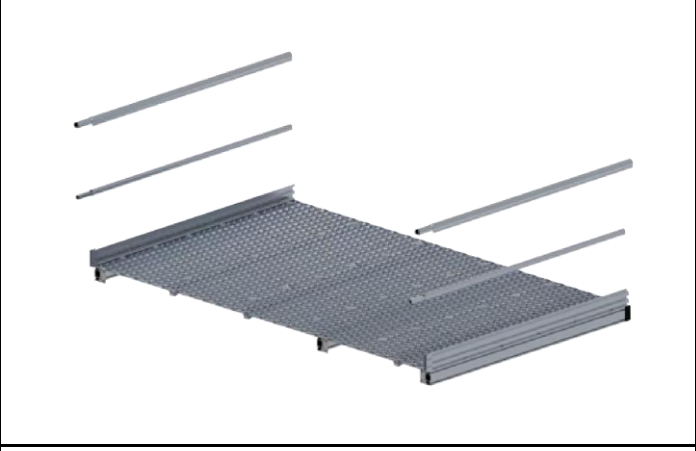
|  |         |  |         |
|--|---------|--|---------|
|     |         |     |         |
| <b>STAIRM.PLAT.REP.G.1250X6000</b>   |         | <b>STAIRM.PLAT.REP.G.1250X5000</b>   |         |
| Length   | 6000mm  | Length   | 5000mm  |
| Width  | 1200mm  | Width  | 1200mm  |
| Mesh   | Regular | Mesh   | Regular |
|   |         |   |         |
| <b>STAIRM.PLAT.REP.G.1250X4000</b>   |         | <b>STAIRM.PLAT.REP.G.1250X3000</b>   |         |
| Length   | 4000mm  | Length   | 3000mm  |
| Width  | 1200mm  | Width  | 1200mm  |
| Mesh   | Regular | Mesh   | Regular |
|  |         |  |         |
| <b>STAIRM.PLAT.REP.G.1250X2000</b>   |         | <b>STAIRM.PLAT.REP.G.1250X1000</b>   |         |
| Length   | 2000mm  | Length   | 1000mm  |
| Width  | 1200mm  | Width  | 1200mm  |
| Mesh   | Regular | Mesh   | Regular |

|  |             |  |             |
|--|-------------|--|-------------|
|     |             |     |             |
| <b>STAIRM.PLAT.REP.S.1850X6000</b>   |             | <b>STAIRM.PLAT.REP.S.1850X5000</b>   |             |
| Length   | 6000mm      | Length   | 5000mm      |
| Width  | 1800mm      | Width  | 1800mm      |
| Mesh   | Small Holes | Mesh   | Small Holes |
|   |             |   |             |
| <b>STAIRM.PLAT.REP.S.1850X4000</b>   |             | <b>STAIRM.PLAT.REP.S.1850X3000</b>   |             |
| Length   | 4000mm      | Length   | 3000mm      |
| Width  | 1800mm      | Width  | 1800mm      |
| Mesh   | Small Holes | Mesh   | Small Holes |
|  |             |  |             |
| <b>STAIRM.PLAT.REP.S.1850.2000</b>   |             | <b>STAIRM.PLAT.REP.S.1850X1000</b>   |             |
| Length   | 2000mm      | Length   | 1000mm      |
| Width  | 1800mm      | Width  | 1800mm      |
| Mesh   | Small Holes | Mesh   | Small Holes |

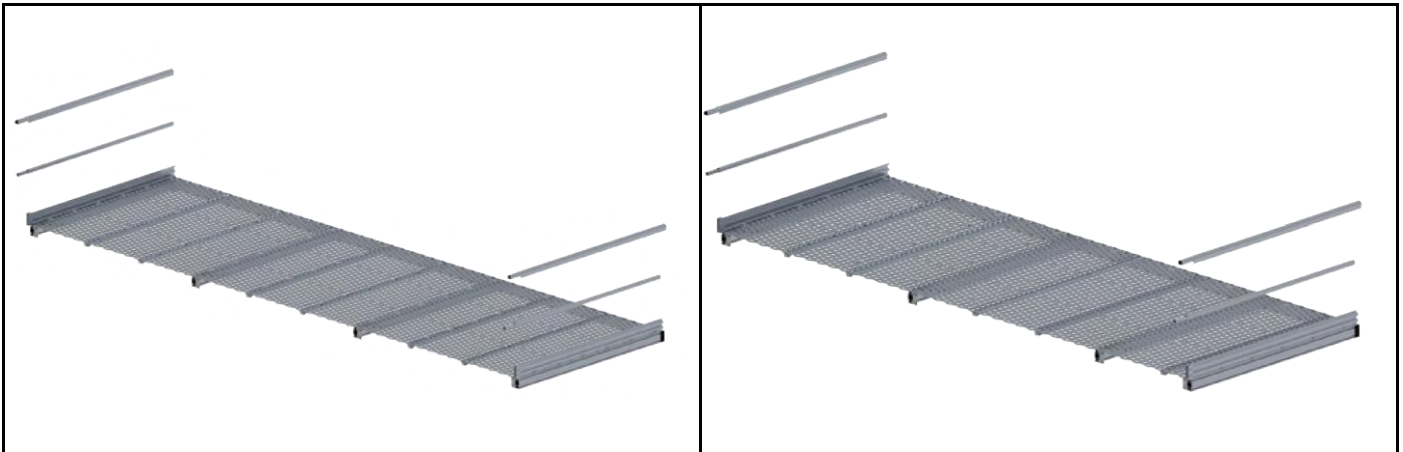

|                                    |         |                                    |         |
|------------------------------------|---------|------------------------------------|---------|
| <b>STAIRM.PLAT.REP.G.1850X6000</b> |         | <b>STAIRM.PLAT.REP.G.1850X5000</b> |         |
| Length                             | 6000mm  | Length                             | 5000mm  |
| Width                              | 1800mm  | Width                              | 1800mm  |
| Mesh                               | Regular | Mesh                               | Regular |

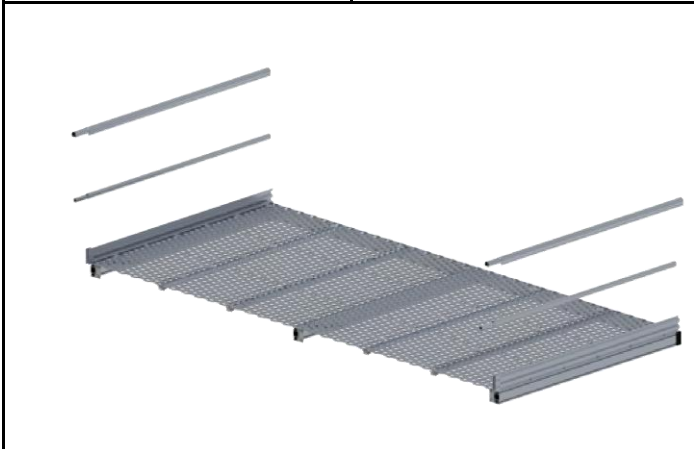



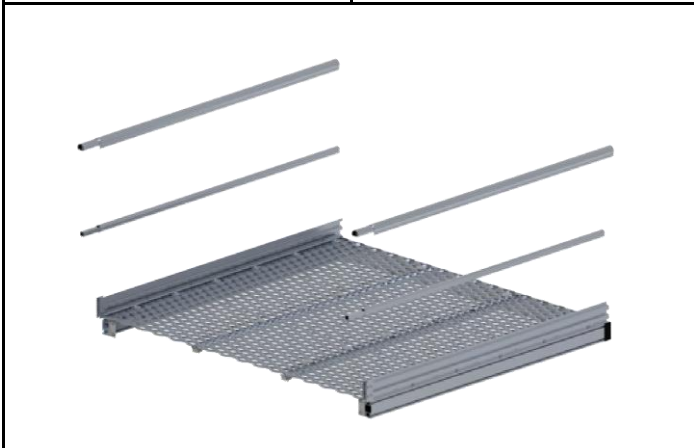



|                                    |         |                                    |         |
|------------------------------------|---------|------------------------------------|---------|
| <b>STAIRM.PLAT.REP.G.1850X4000</b> |         | <b>STAIRM.PLAT.REP.G.1850X3000</b> |         |
| Length                             | 4000mm  | Length                             | 3000mm  |
| Width                              | 1800mm  | Width                              | 1800mm  |
| Mesh                               | Regular | Mesh                               | Regular |









|                                    |         |                                    |         |
|------------------------------------|---------|------------------------------------|---------|
| <b>STAIRM.PLAT.REP.G.1850X2000</b> |         | <b>STAIRM.PLAT.REP.G.1850X1000</b> |         |
| Length                             | 2000mm  | Length                             | 1000mm  |
| Width                              | 1800mm  | Width                              | 1800mm  |
| Mesh                               | Regular | Mesh                               | Regular |

2.3.5 Support Kits

Figure 7

|   |        |   |            |
|---|--------|---|------------|
|    |        |    |            |
| <b>STAIRM.SUPP.686X2200</b>   |        | <b>STAIRM.SUPP.686X1500</b>   |            |
| Max Height  | 2200mm | Max Height  | 1500mm     |
| Width   | 686mm  | Width   | 686mm      |
|   |        |   |            |
| <b>STAIRM.SUPP.686X800</b>  |        | <b>STAIRM.SUPP.686X300</b>  |            |
| Max Height  | 800mm  | Max Height  | 300mm      |
| Width   | 686mm  | Width   | 686-1850mm |
|  |        |  |            |
| <b>STAIRM.SUPP.1250X2200</b>  |        | <b>STAIRM.SUPP.1250X1500</b>  |            |
| Max Height  | 2200mm | Max Height  | 1500mm     |
| Width   | 1250mm | Width   | 1250mm     |

|   |        |   |        |
|---|--------|---|--------|
|    |        |    |        |
| <b>STAIRM.SUPP.1250X800</b>   |        | <b>STAIRM.SUPP.1850X2200</b>  |        |
| Max Height  | 800mm  | Max Height  | 2200mm |
| Width   | 1250mm | Width   | 1850mm |
|   |        |    |        |
| <b>STAIRM.SUPP.1850X1500</b>  |        | <b>STAIRM.SUPP.1850X800</b>   |        |
| Max Height  | 1500mm | Max Height  | 800mm  |
| Width   | 1850mm | Width   | 1850mm |
|  |        |  |        |
| <b>STAIRM.SUPP.REP.1250X2200</b>  |        | <b>STAIRM.SUPP.REP.1250X1500</b>  |        |
| Max Height  | 2200mm | Max Height  | 1500mm |
| Width   | 1250mm | Width   | 1250mm |

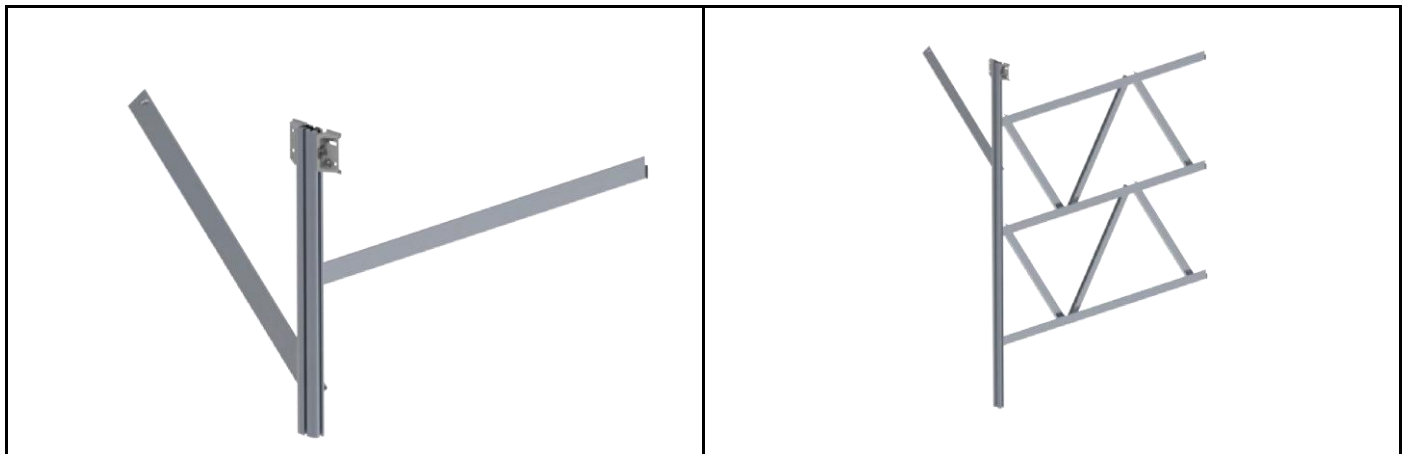

**STAIRM.SUPP.REP.1250X800**

**STAIRM.SUPP.REP.1850X2200**

|            |        |
|------------|--------|
| Max Height | 800mm  |
| Width      | 1250mm |

|            |        |
|------------|--------|
| Max Height | 2200mm |
| Width      | 1850mm |



**STAIRM.SUPP.REP.1850X1500**

|            |        |
|------------|--------|
| Max Height | 1500mm |
| Width      | 1850mm |

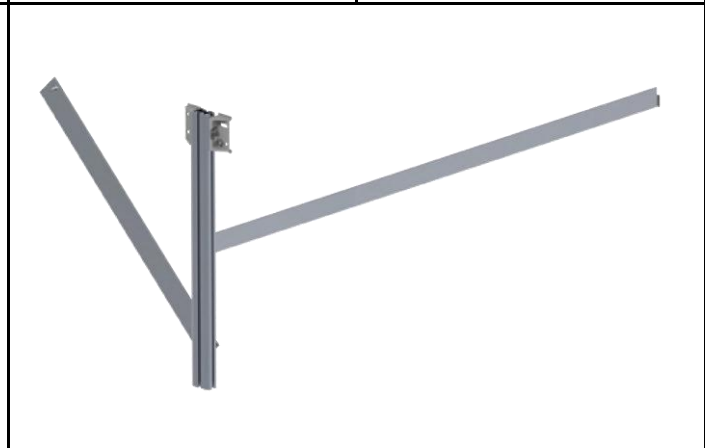

**STAIRM.SUPP.REP.1850X800**

|            |        |
|------------|--------|
| Max Height | 800mm  |
| Width      | 1850mm |



**STAIRM.SUPP.WALL.1250**

|                    |        |
|--------------------|--------|
| Max Platform Width | 1250mm |
|--------------------|--------|



**STAIRM.SUPP.WALL.686**

|                    |       |
|--------------------|-------|
| Max Platform Width | 686mm |
|--------------------|-------|



**STAIRM.SUPP.WALL.CON**

Max Offset





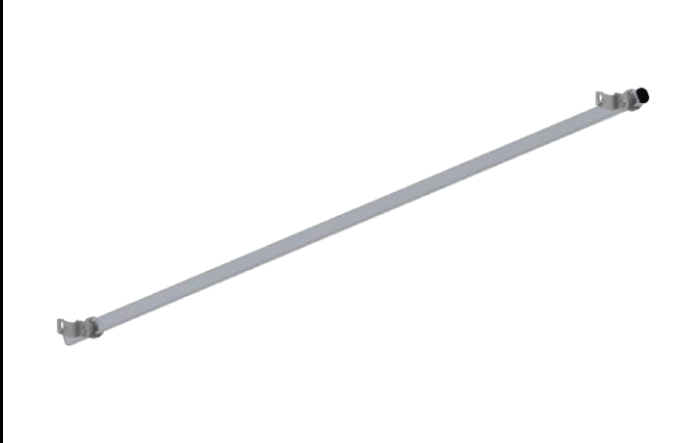
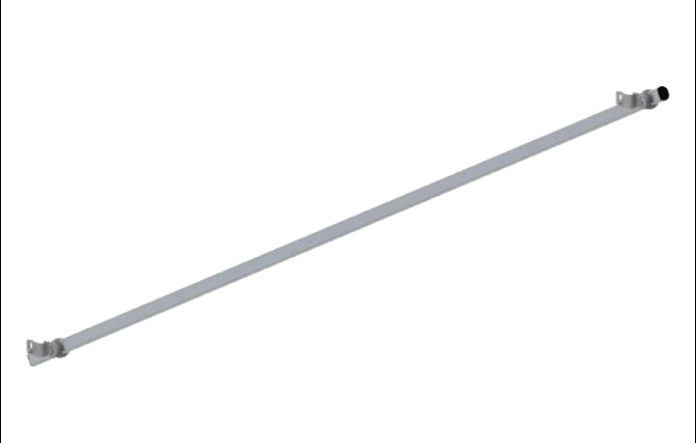
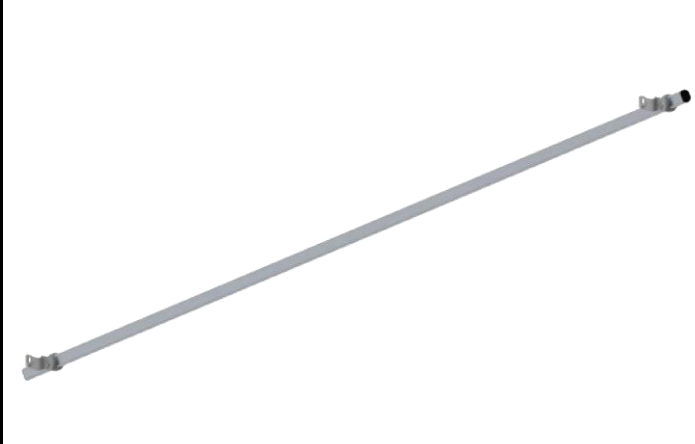
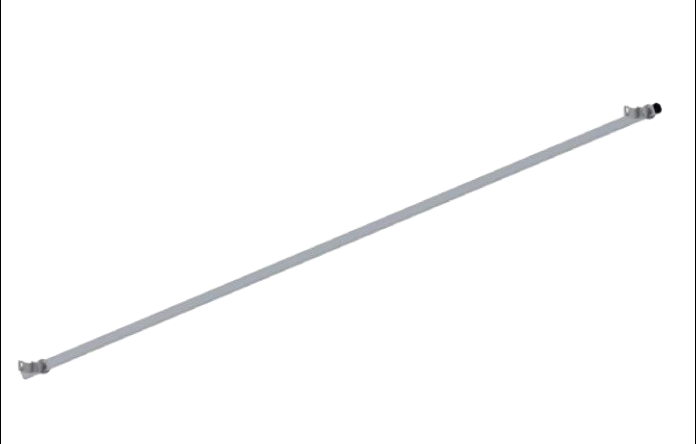

100mm

### 2.3.6 Cross Brace Kits

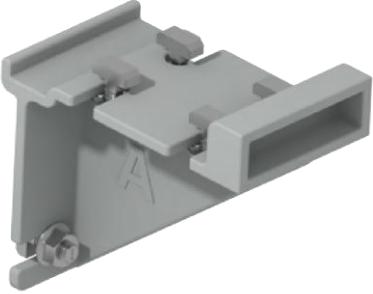

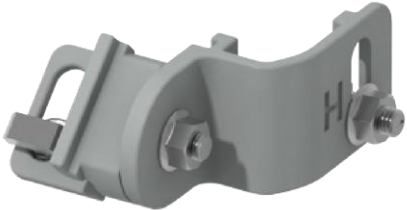



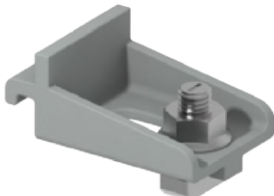

| <b>Figure 8</b>   |        |   |        |
|---|--------|---|--------|
|   |        |   |        |
| <b>STAIRM.BRACE.2500</b>  |        | <b>STAIRM.BRACE.3000</b>  |        |
| Rail length   | 2500mm | Rail length   | 3000mm |
|  |        |  |        |
| <b>STAIRM.BRACE.3500</b>  |        | <b>STAIRM.BRACE.4000</b>  |        |
| Rail length   | 3500mm | Rail length   | 4000mm |

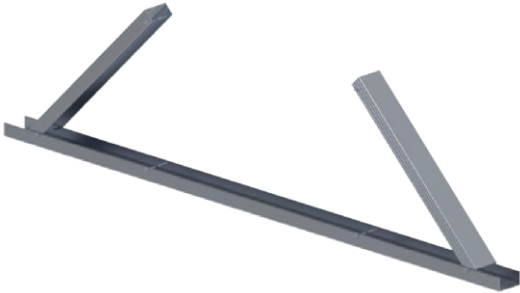
2.3.7 Components

Figure 9

|   |   |
|---|---|
|    |    |
| <p><b>STAIRM.BRKT.KIT.A</b></p>   | <p><b>STAIRM.BRKT.KIT.B</b></p>   |
| <p>STAIR BRACKET KIT</p>  | <p>POST BRACKET KIT</p>   |
|   |     |
| <p><b>STAIRM.BRKT.KIT.C</b></p>   | <p><b>STAIRM.BRKT.KIT.DH</b></p>  |
| <p>CORNER BRACKET KIT</p>   | <p>STRINGER POST BRACKET KIT</p>  |
|  |  |
| <p><b>STAIRM.BRKT.KIT.E</b></p>   | <p><b>STAIRM.BRKT.KIT.F</b></p>   |
| <p>HANGER BRACKET KIT</p>   | <p>FOOT BRACKET KIT</p>   |
|  |  |
| <p><b>STAIRM.BRKT.KIT.GH</b></p>  | <p><b>STAIRM.BRKT.I</b></p>   |
| <p>BRACE BRACKET KIT</p>  | <p>CLIP BRACKET KIT</p>   |

|   |  |
|---|--|
|    |   |
| <p><b>STAIRM.BRKT.KIT.J</b></p>   | <p><b>STAIRM.BRKT.KIT.K</b></p>  |
| <p>PLATFORM SPLICE KIT</p>  | <p>PLATFORM BRACKET TO STRUCTURE</p>   |
|    |    |
| <p><b>STAIRM.BRK.LND90M</b></p>   | <p><b>STAIRM.BRK.LND75M</b></p>  |
| <p>90 DEGREE LADDER BRACKET</p>   | <p>75 DEGREE LADDER BRACKET</p>  |
|  |  |
| <p><b>STAIRM.TREAD.2.1200</b></p>   | <p><b>STAIRM.TREAD.2.9600</b></p>  |
| <p>TREAD KIT, 2 STEP, WIDTH 1200</p>  | <p>TREAD KIT, 2 STEP, WIDTH 900</p>  |
|  |  |
| <p><b>STAIRM.TREAD.2.600</b></p>  | <p><b>STAIRM.FOOT.KIT.CC</b></p>   |
| <p>TREAD KIT, 2 STEP, WIDTH 600</p>   | <p>SUPPORT FOOTING KIT, CONCRETE</p>   |

|   |   |
|---|---|
|    |    |
| <p><b>STAIRM.FOOT.KIT.SM</b></p>  | <p><b>STAIRM.PLAT.POST</b></p>  |
| <p>SUPPORT FOOTING KIT, SHEET METAL</p>   | <p>PLATFORM GUARDRAIL POST</p>  |
|    |    |
| <p><b>GUARD001.TOOL.KR.K</b></p>  | <p><b>STAIRM.JACK.KIT</b></p>   |
| <p>KNEERAIL INSTALLATION KIT</p>  | <p>STAIR AND PLATFORM JACK KIT</p>  |
|  |  |
| <p><b>CON-M10X130</b></p>   | <p><b>CON-MECH-FISV.10.30</b></p>   |
| <p>CHEMICAL CONCRETE FASTENER</p>   | <p>MECHANICAL CONCRETE FASTENER</p>   |
|  |  |
| <p><b>STAIRM.TOE.CORNER.K</b></p>   | <p><b>STAIRM.TOE.JOIN.K</b></p>   |
| <p>TOE BOARD CORNER KIT</p>   | <p>TOE BOARD JOIN KIT</p>   |

### 3 Installation

#### 3.1 System Design and Selection

##### 3.1.1 Location

Determining the best location for your access system can be difficult. SafetyLink recommends a risk assessment be conducted to accurately assess the key hazards of your particular work area. Hazards include but are not limited to; ingress and egress from the access system, machinery and vehicles use in the area, electrical conductivity and chemical agents.

##### 3.1.2 Mesh Support Spacing

The mesh supports shall be spaced no greater than 700mm apart.

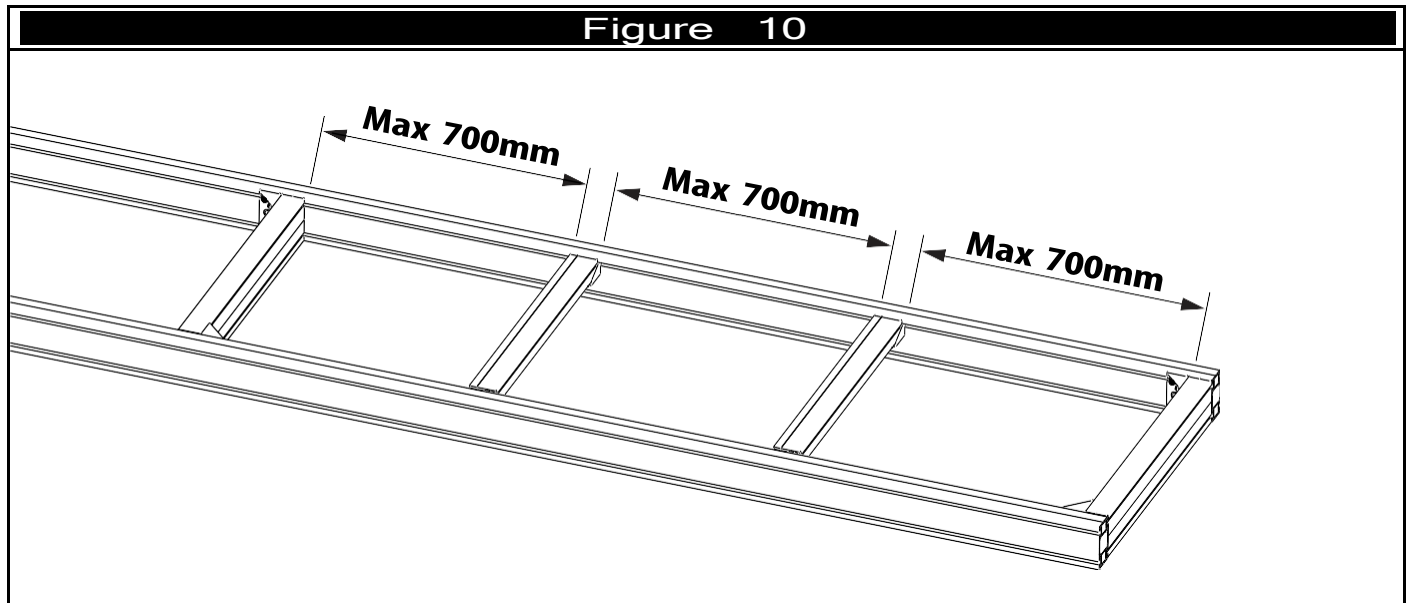

##### 3.1.3 Mesh Join Location

Joins in the mesh shall not be more than 200mm from a support.

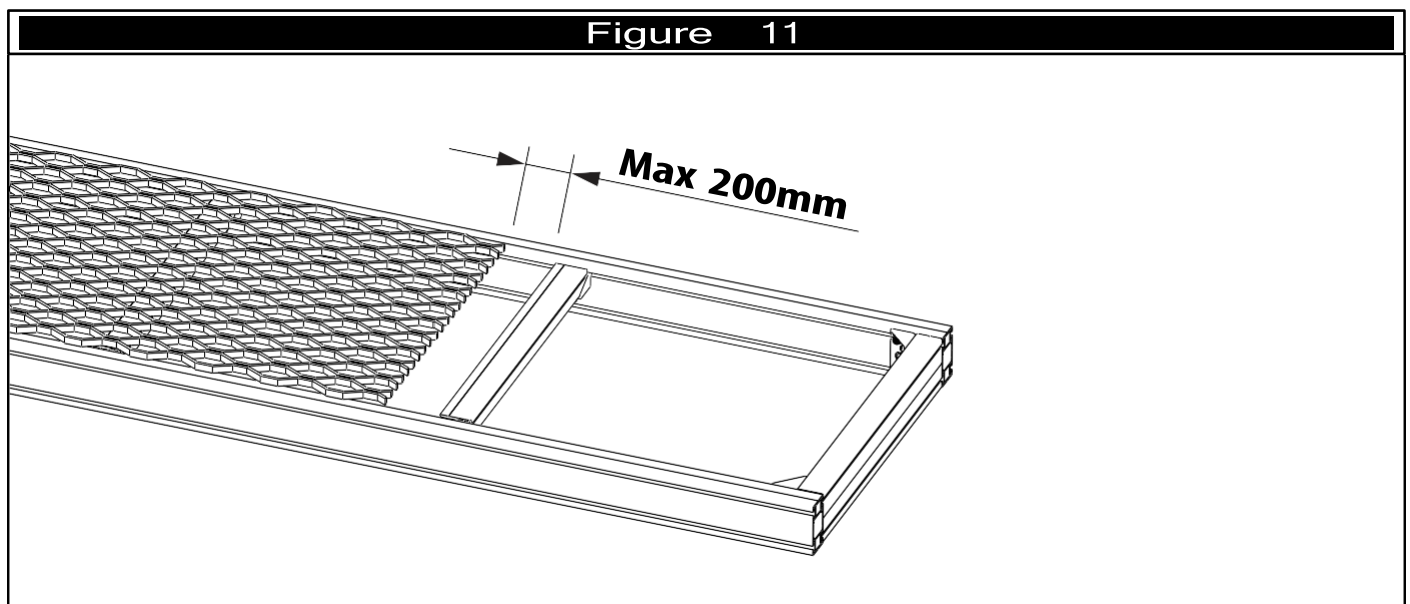

### 3.1.4 Guardrail and Toeboard Post Spacing

Guardrail and toe board supporting posts shall be spaced at a maximum of 3000mm.

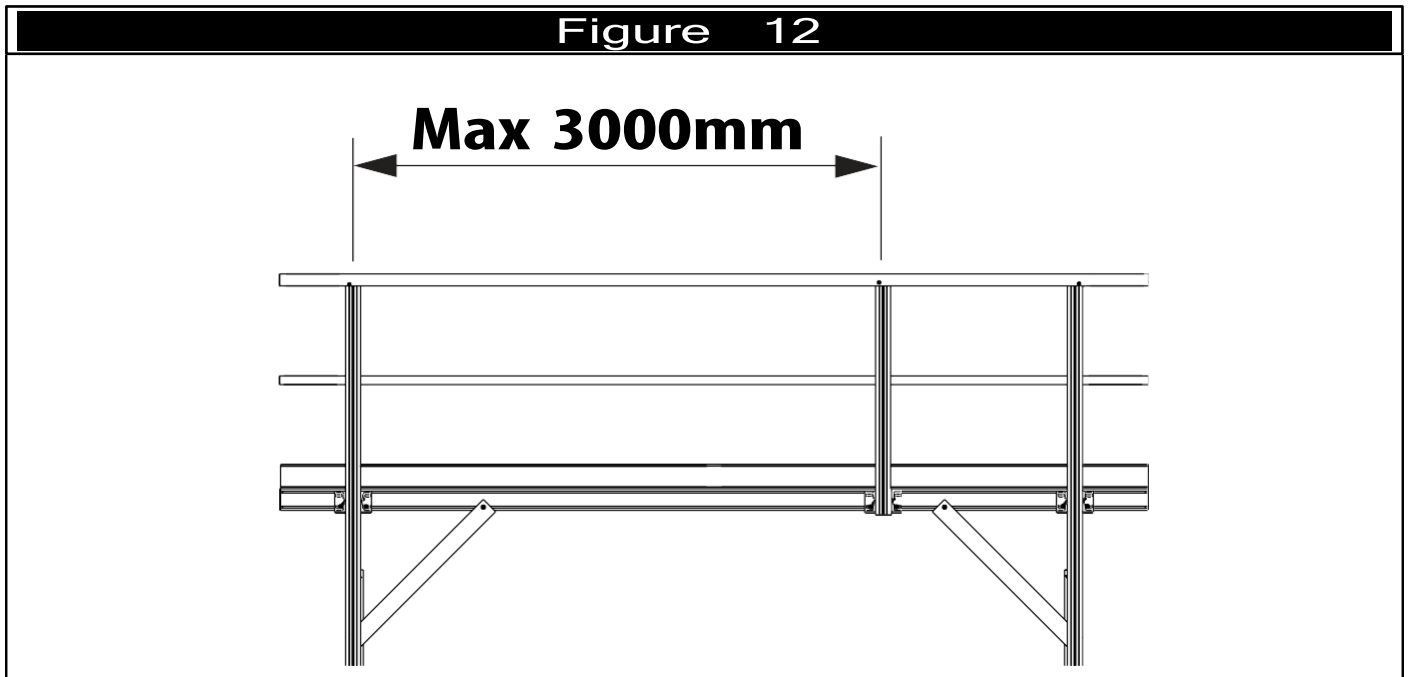

### 3.1.5 Guardrail, Guardrail Joins, Toeboard and Platform Over Hang

At the end of a platform, the guardrail, guardrail joins, toeboard and platform shall not overhang a support post by more than 300mm.

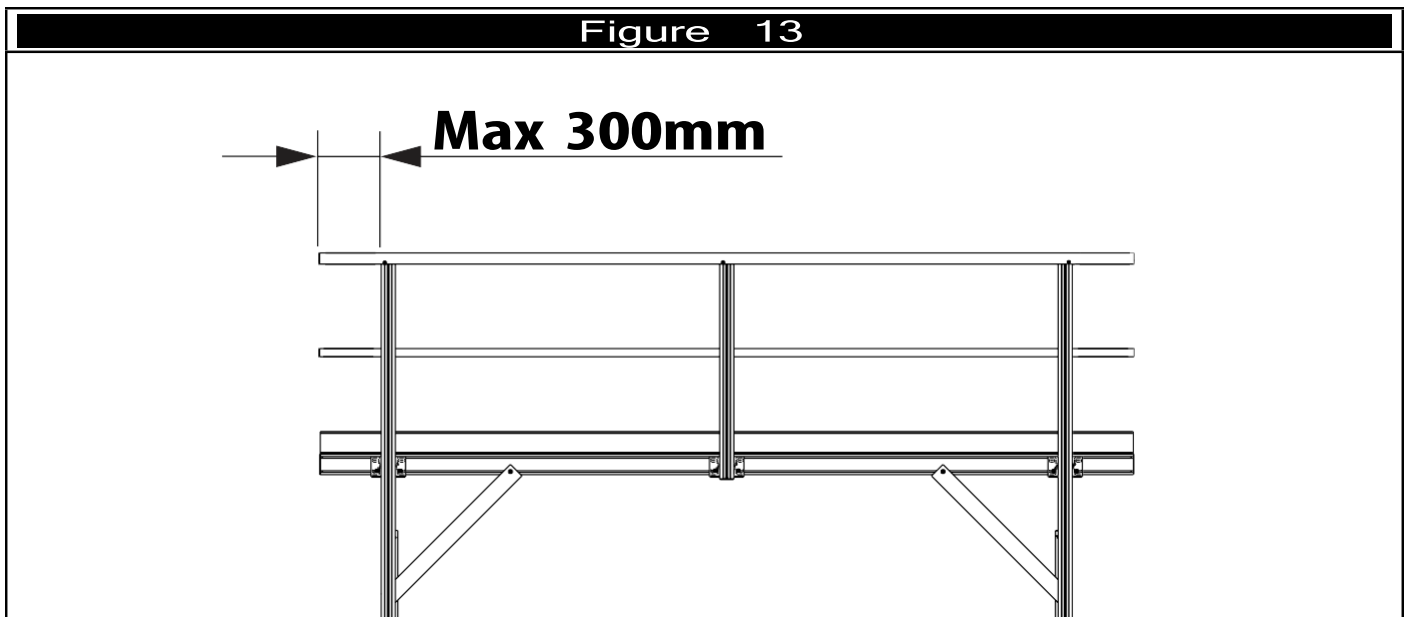

### 3.1.6 Stair Angle

Stair angle shall be between 30 and 45 degrees from horizontal.

- ☑ This equates to a tread rise of between 219 and 155mm.

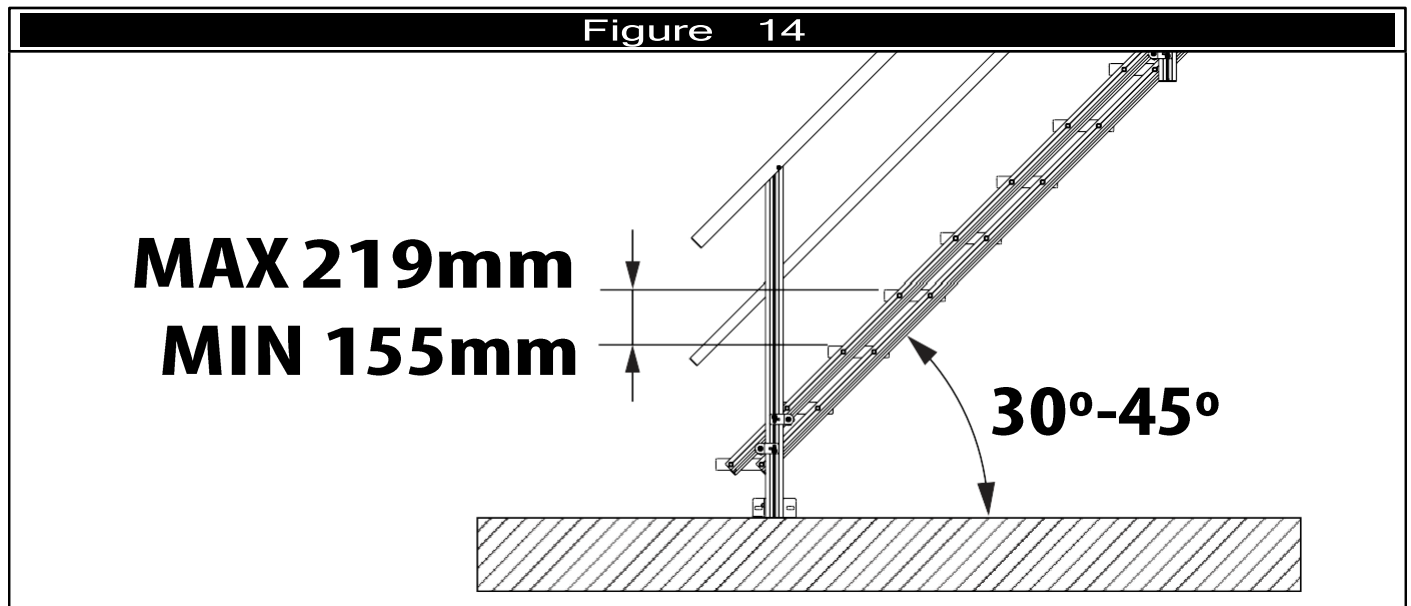

### 3.1.7 Staircase Support

There shall be no more that 10 treads between supports.

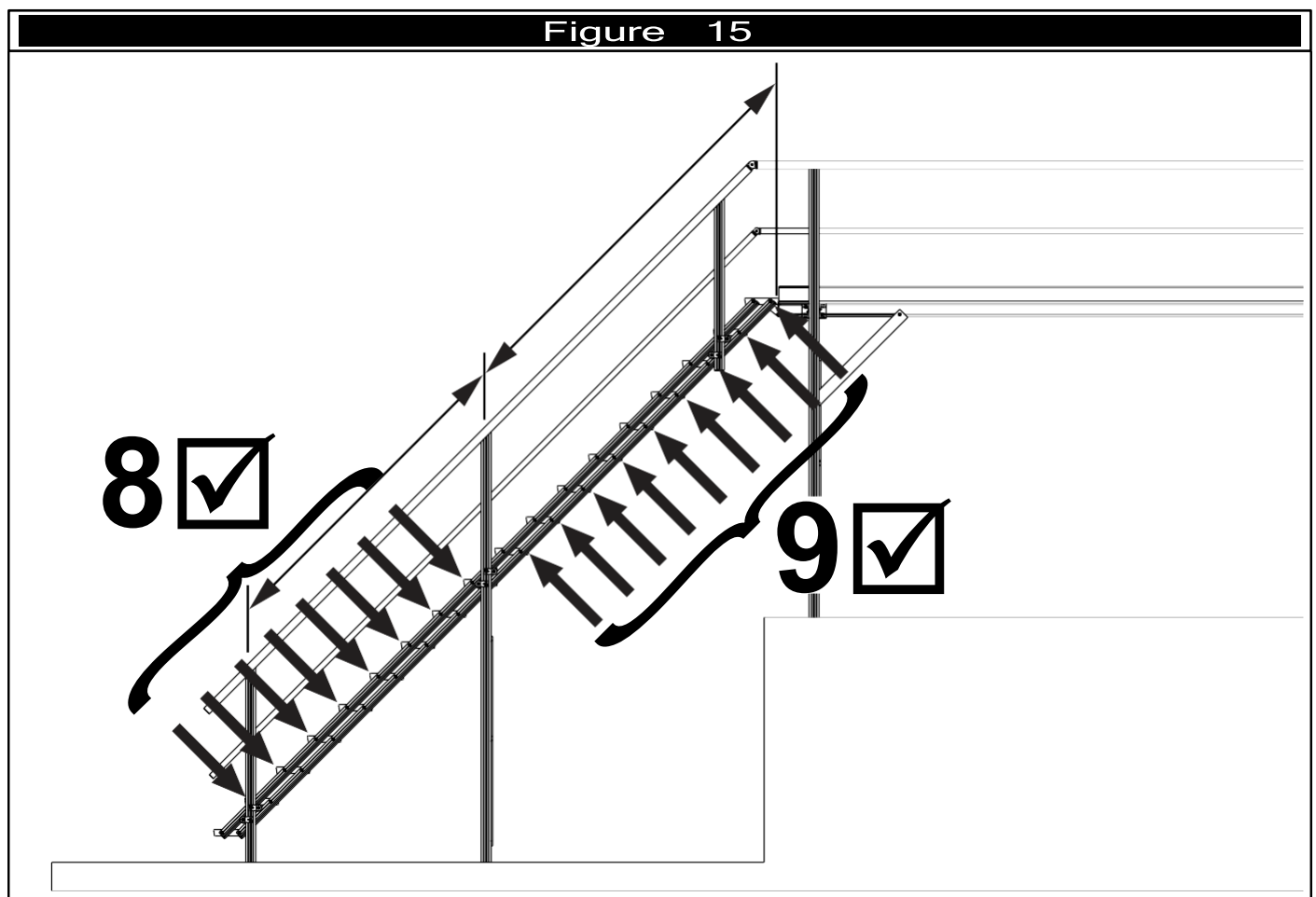

### 3.1.8 Platform Width (Outer Frame)

The platform outer frame may be made from multiple sections separated by length extrusions. Any section of an outer frame shall not exceed 1800mm when measured between the centrelines of the length extrusions. Sections do not need to be equal widths or lengths.

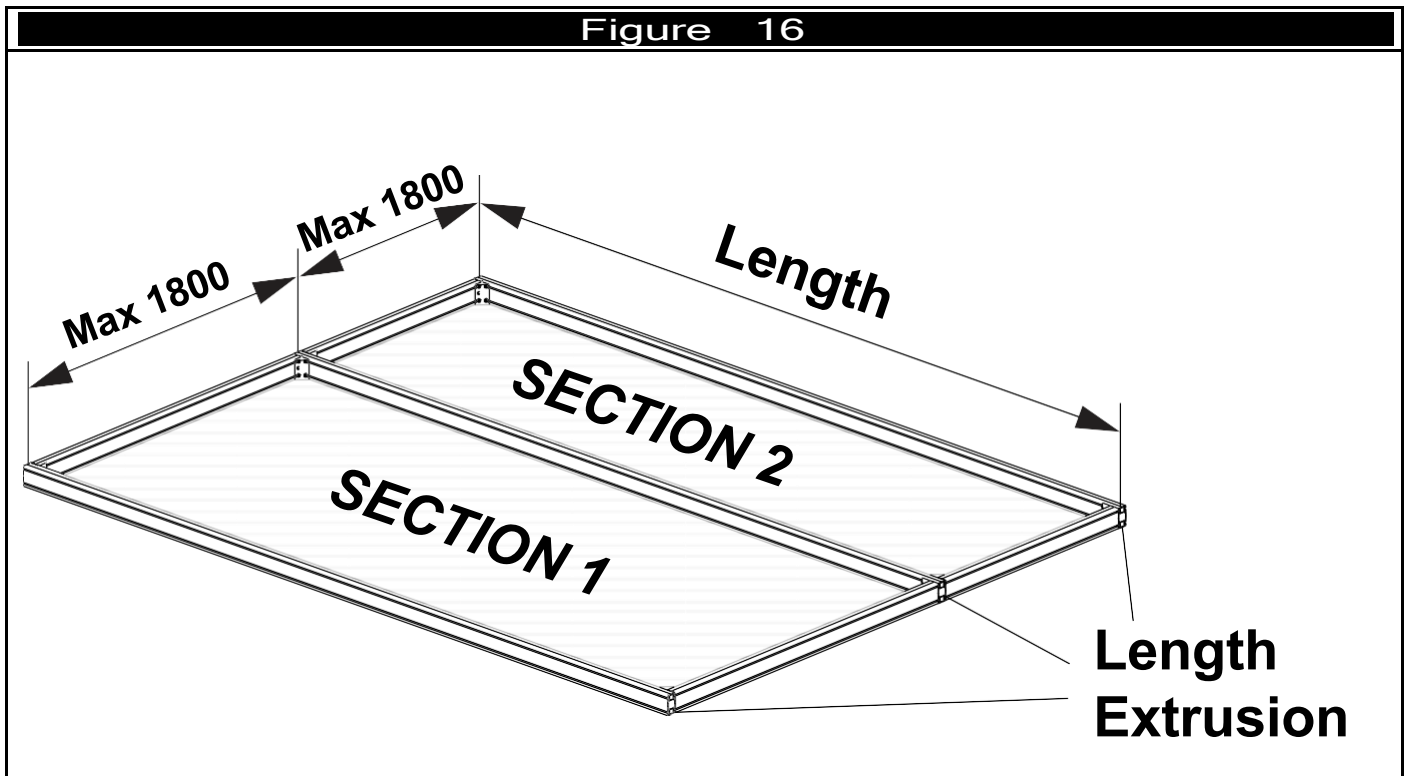

### 3.1.9 Platform Height

The surface of the platform shall not be higher than 2200mm above the ground.

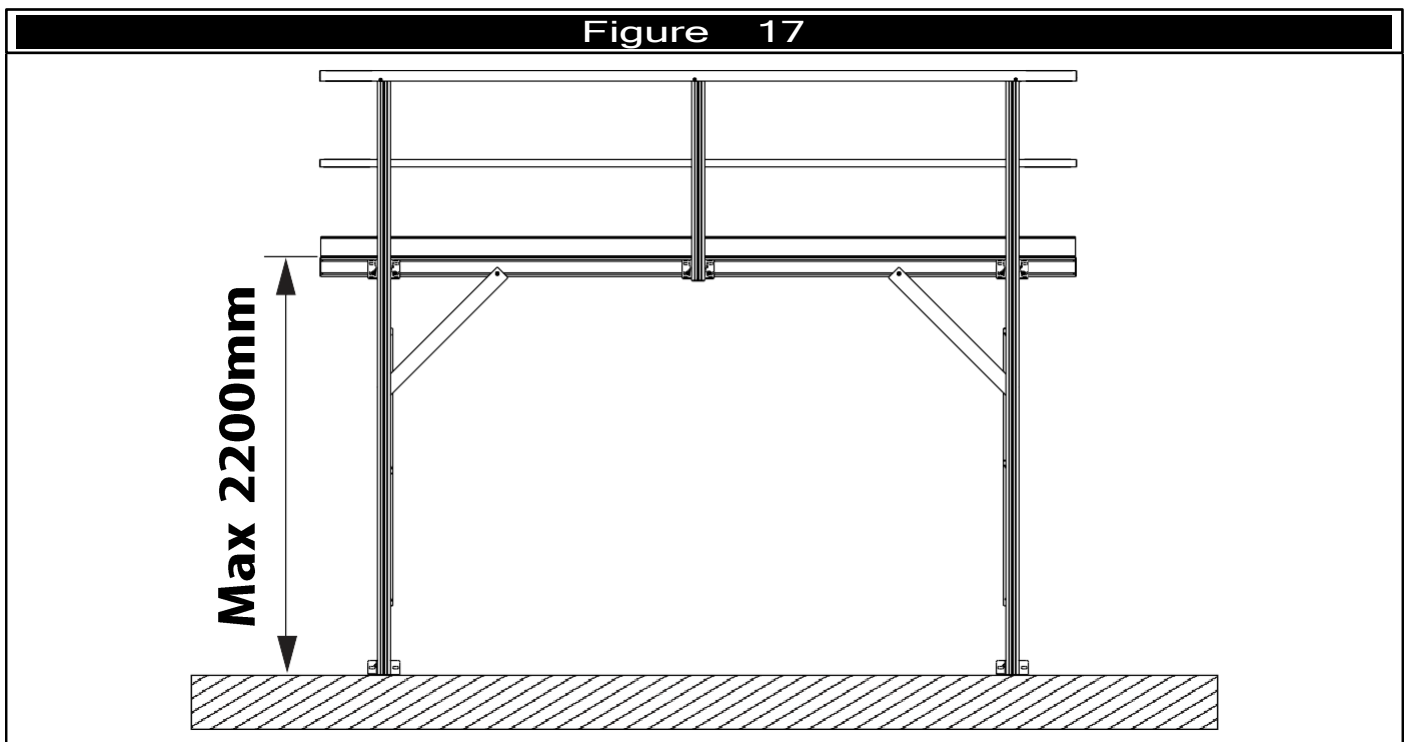

### 3.1.10 Platform Support Post Spacing

The distance between platform support posts shall not exceed the numbers in Figure 18.

⚠ *Platforms containing multiple sections have different support distances. This is required because the internal posts support a larger area than for a single section.*

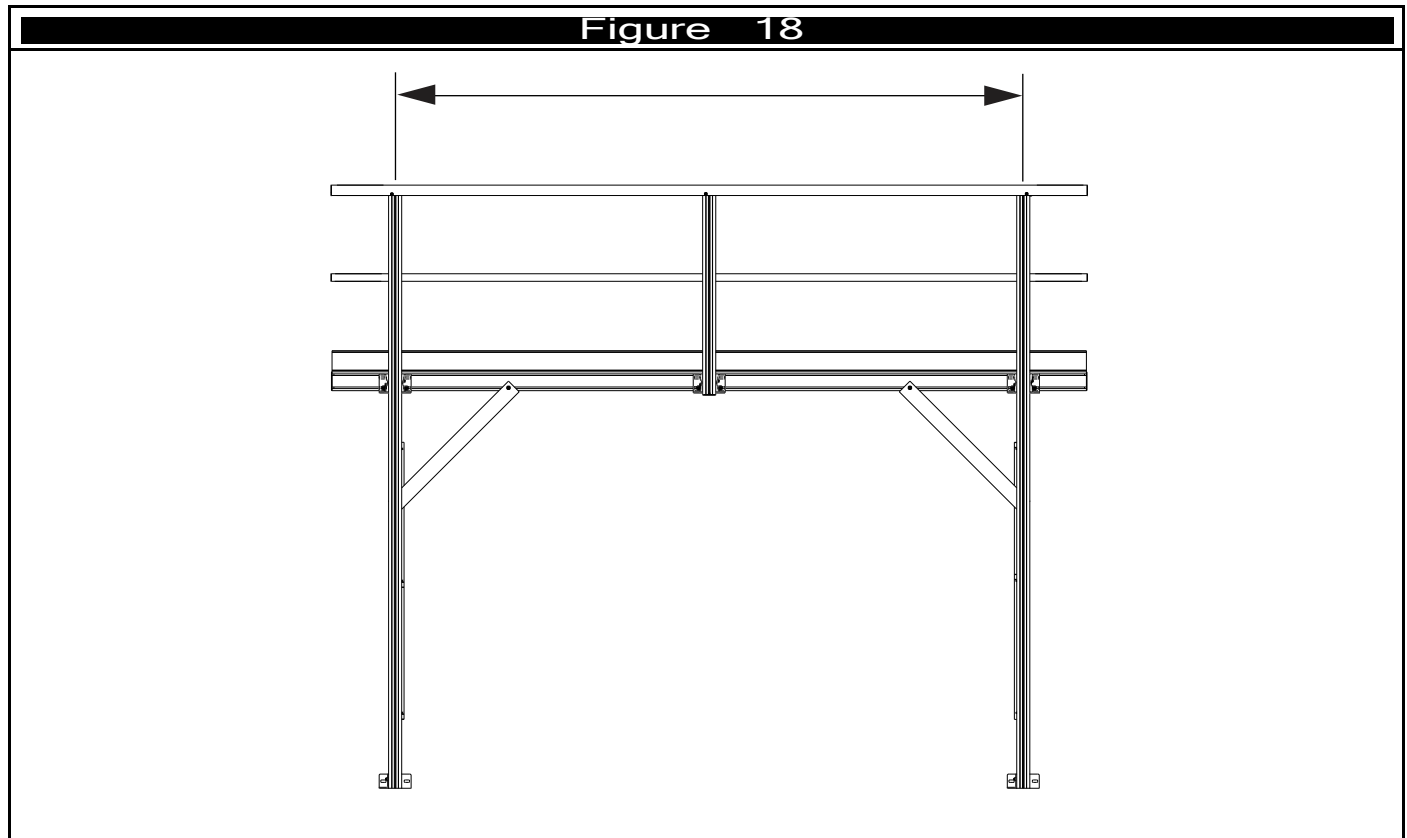

| <b>SECTIONS</b> | <b>PLATFORM WIDTH (mm)</b> | <b>MAX SPAN (mm)</b> |
|-----------------|----------------------------|----------------------|
| SINGLE          | 686                        | 4000                 |
| SINGLE          | 1250                       | 3400                 |
| SINGLE          | 1850                       | 2800                 |
| MULTIPLE        | 1250                       | 2400                 |
| MULTIPLE        | 1850                       | 2100                 |

### 3.1.11 Platform Support

Each length extrusion of the outer frame shall be supported at the distances specified in Section 3.1.10.

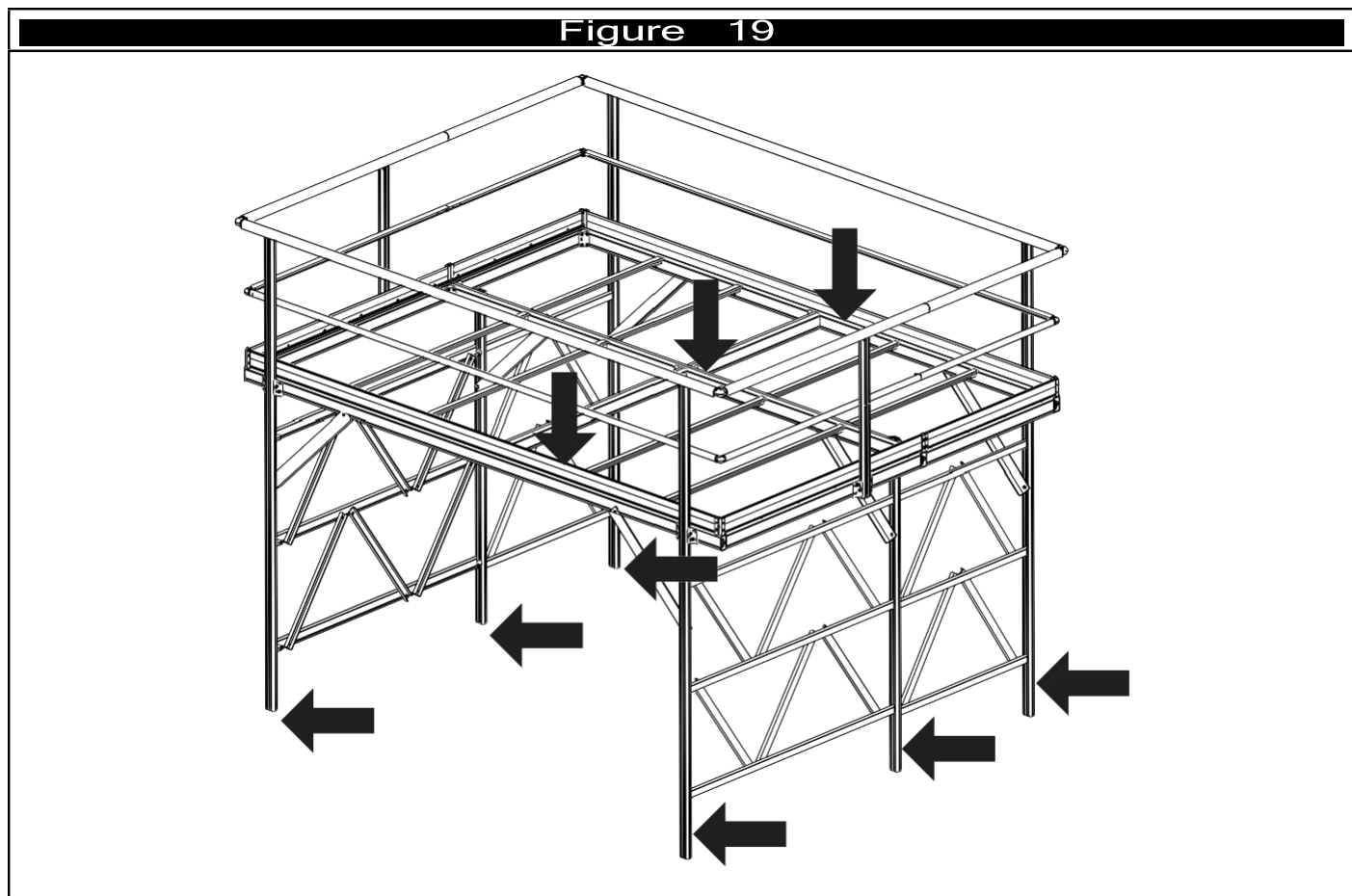

### 3.1.12 Platform Wall Support

The span between wall mounted supports shall not exceed the maximum in Figure 20

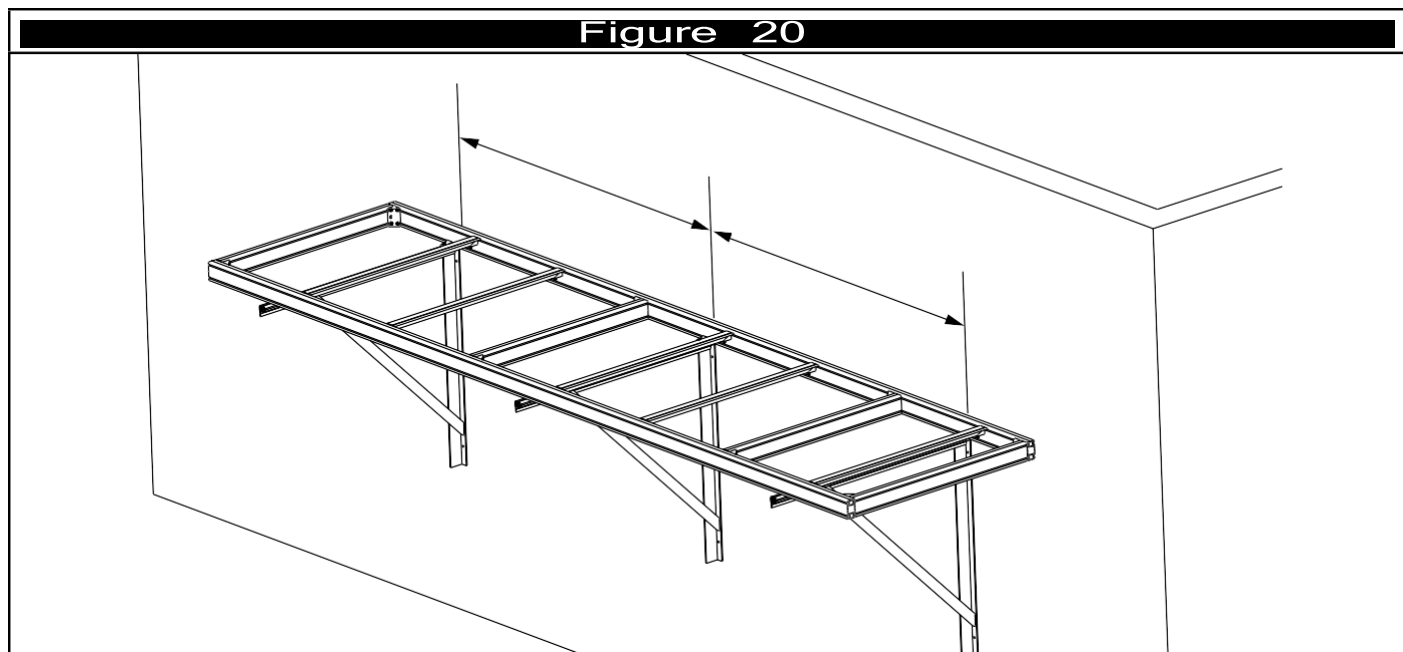

| <b>PLATFORM WIDTH</b> | <b>SPAN</b> |
|-----------------------|-------------|
| 686mm                 | 3000mm      |
| 687-1250mm            | 2000mm      |
| Greater then 1250     | Not Allowed |

### 3.1.13 Platform Braces

☑ Platforms with platform support STAIRM.SUPP.686X300 do not require braces.

Platforms with a post spacing of less than 1.5m shall be fitted with either:

- I 1x set of two braces on one end or;
- II 1x brace at either end.

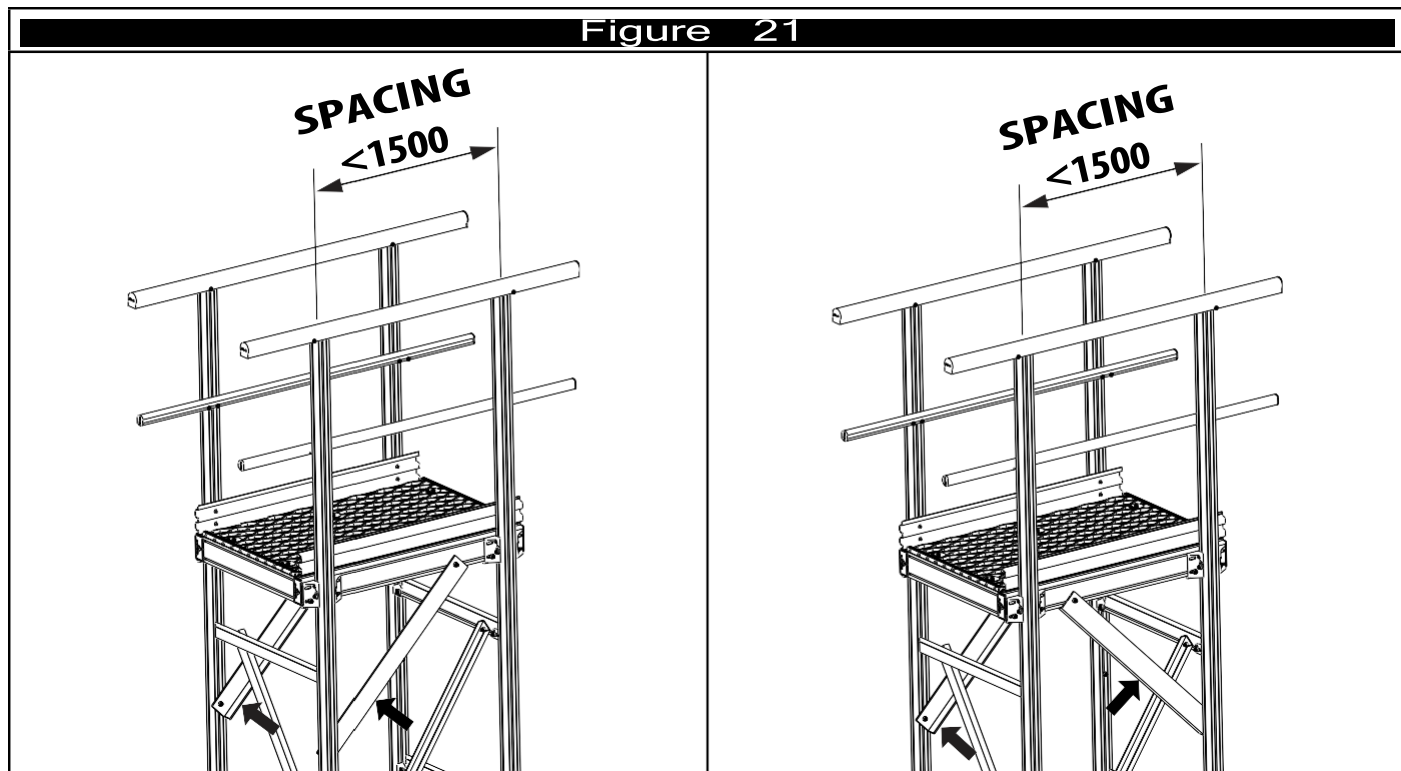

Platforms with a post spacing of more than 1.5m shall be fitted with 1x set of two braces at each end.

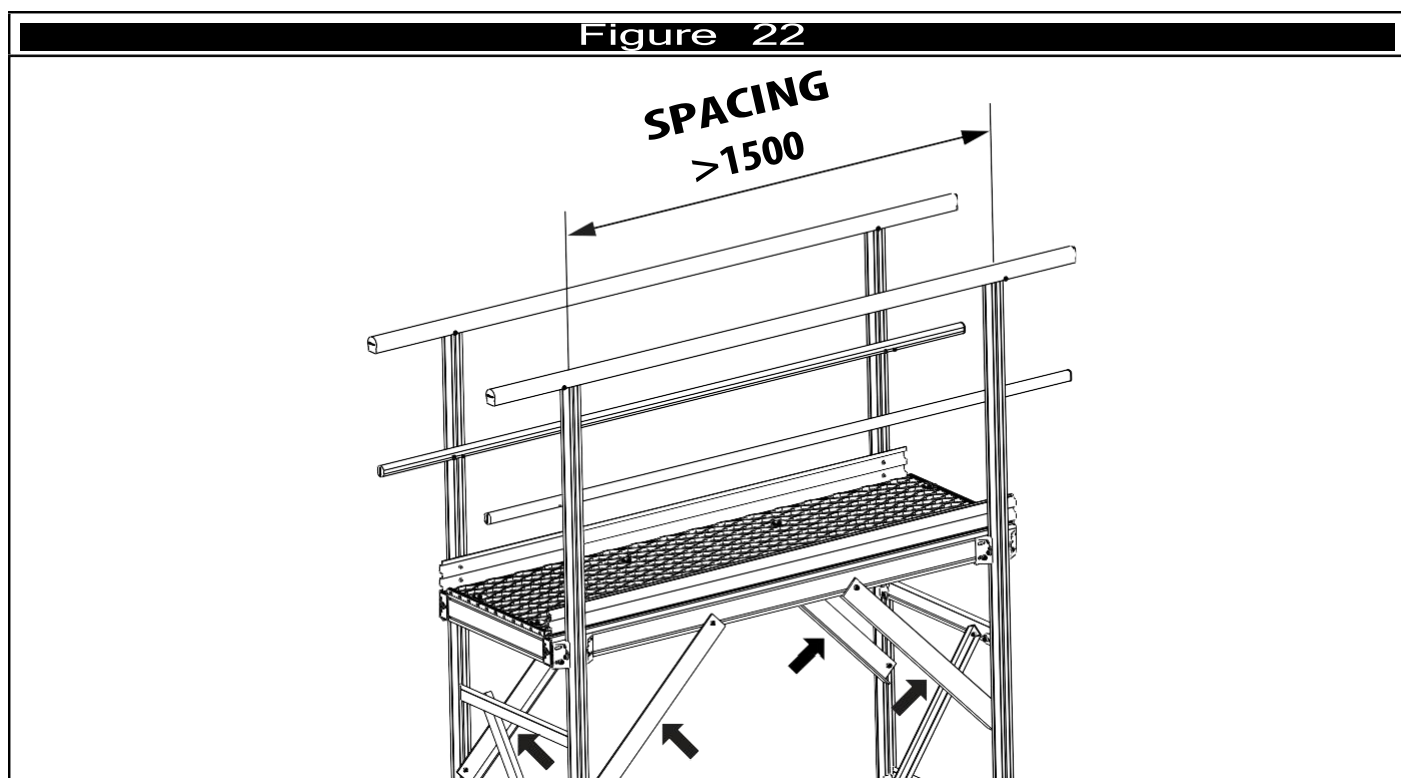

### 3.1.14 Cross Bracing

Platforms wider than 686mm and over 1000mm tall require cross bracing. The cross bracing shall run between the two adjacent support structures, on either side of each section of the platform. Preferably the cross braces on either side run in opposite directions.

Figure 23

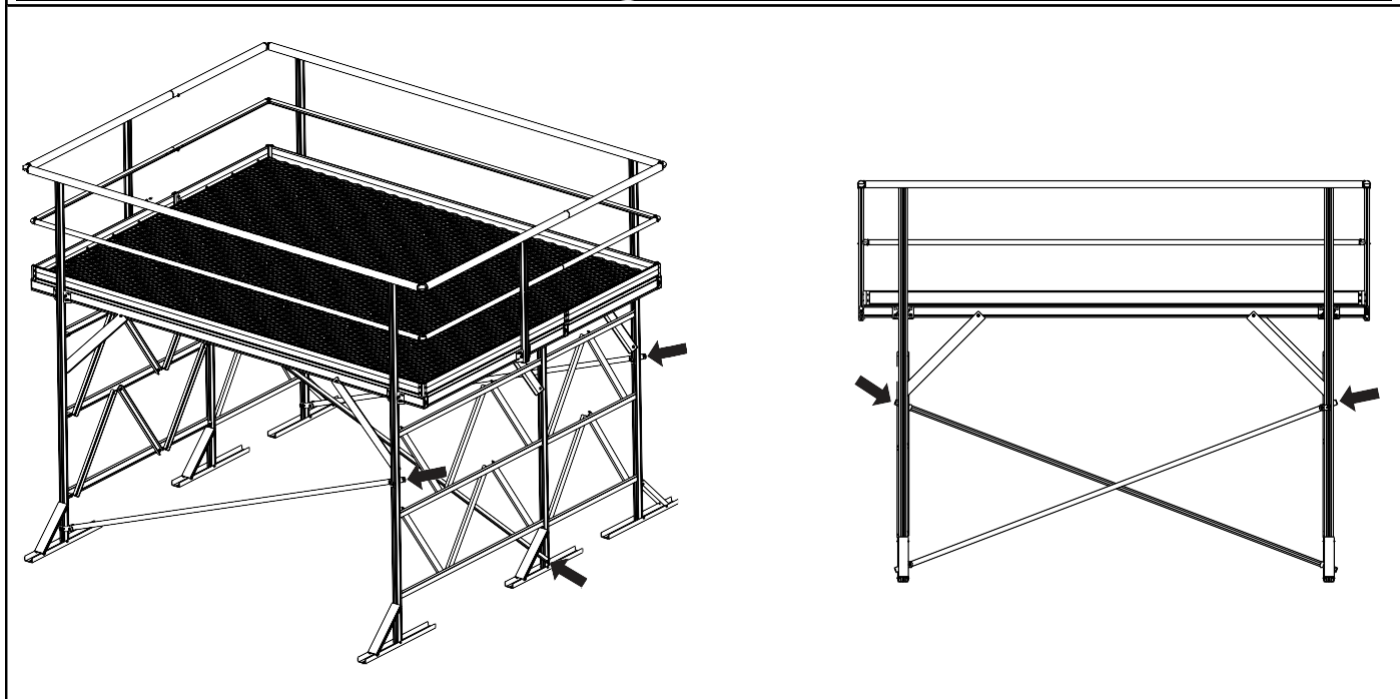

### 3.1.15 Platform Connected to Structure

Cross bracing (as per Section 3.1.14) can be eliminated if the platform is connected to rigid structure with bracket STAIRM.SUPP.WALL.CON. To eliminate all cross braces the platform shall be connected along 2 perpendicular edges (a length and a width edge of the platform) at every support post. See Figure 24.

Figure 24

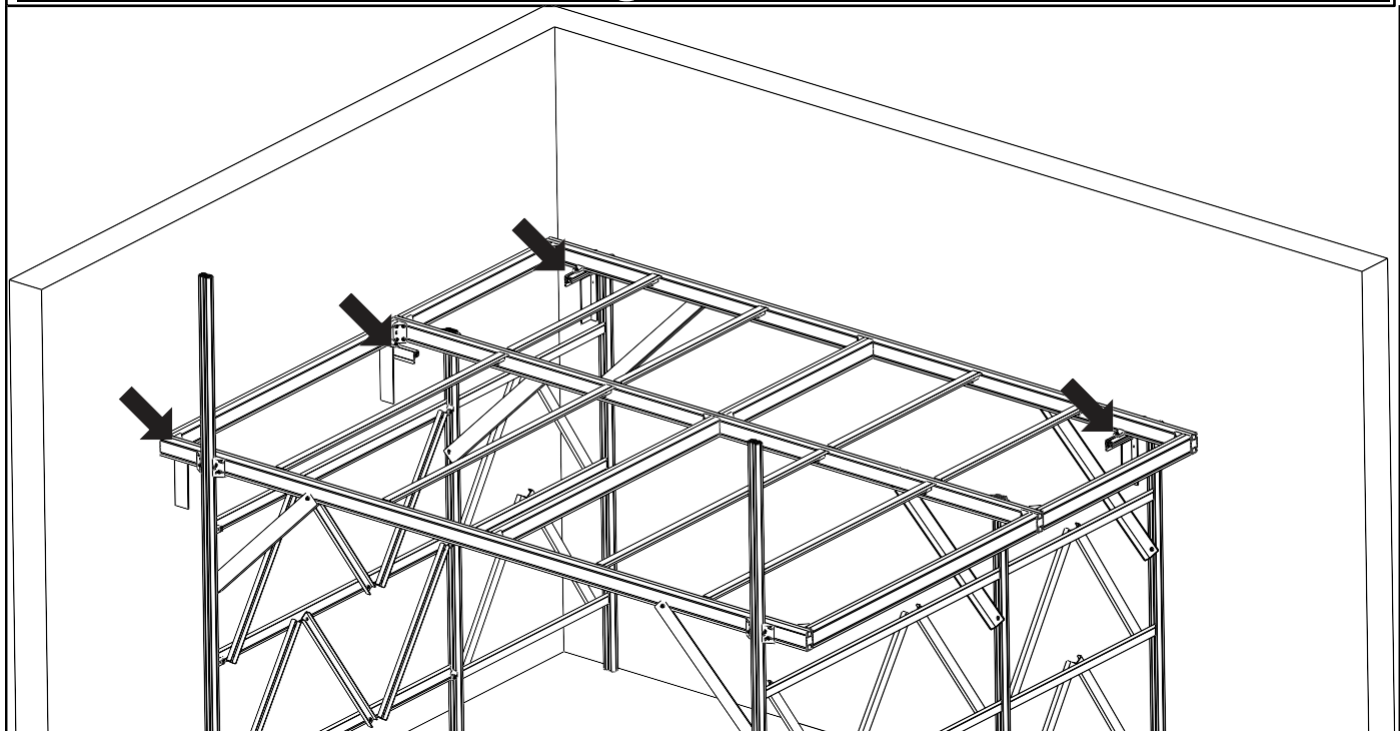

### 3.1.16 Platform Joins

Platform joins shall be within 300mm of a support structure.

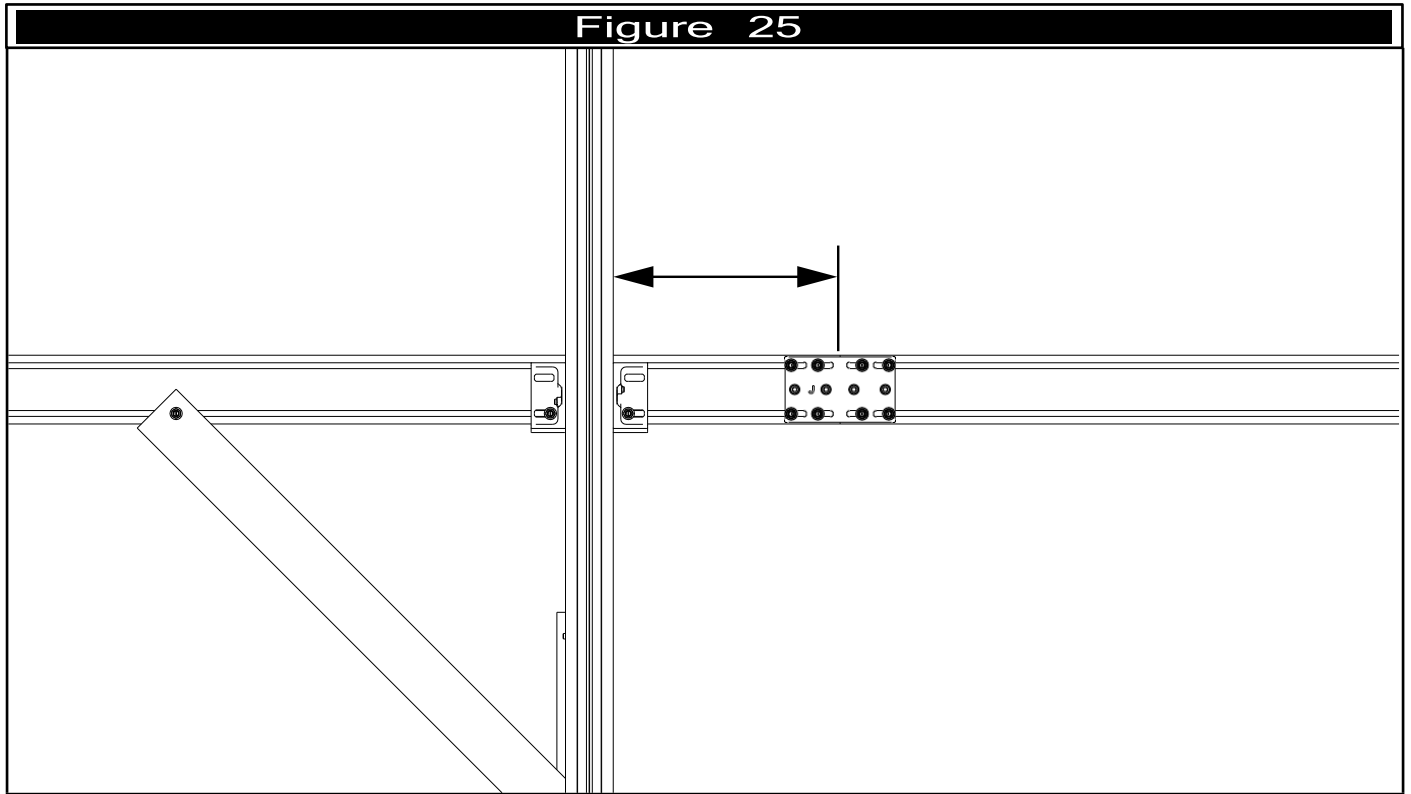

### 3.1.17 Support Structure Configurations (Stairs and Platforms)

Figure 26 shows the various support structure configuration for platforms of different heights and widths.

- Minimum surface height achievable is 175mm.

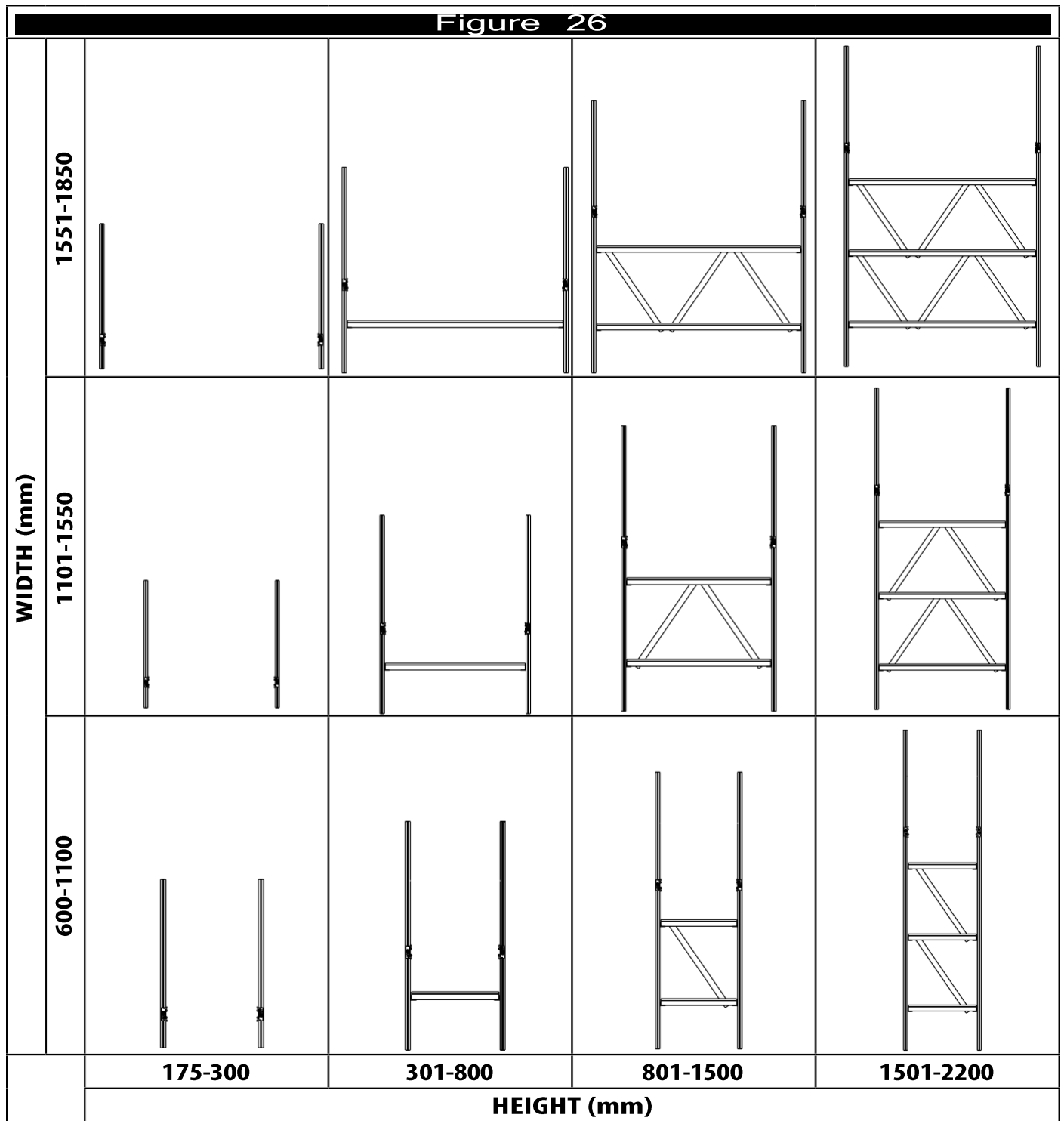

| WIDTH (MM)  | ALL                     | 600-1100              | 1101-1550 | 1551-1850 |
|-------------|-------------------------|-----------------------|-----------|-----------|
| HEIGHT (MM) | HORIZONTAL BRACES (NO.) | DIAGONAL BRACES (NO.) |           |           |
| 175-300     | 0                       | 0                     | 0         | 0         |
| 301-800     | 1                       | 0                     | 0         | 0         |
| 801-1500    | 2                       | 1                     | 2         | 3         |
| 1501-2200   | 3                       | 2                     | 4         | 6         |

### 3.1.18 Support Structure Configurations

The unsupported section of any platform support structure shall not exceed 400mm.

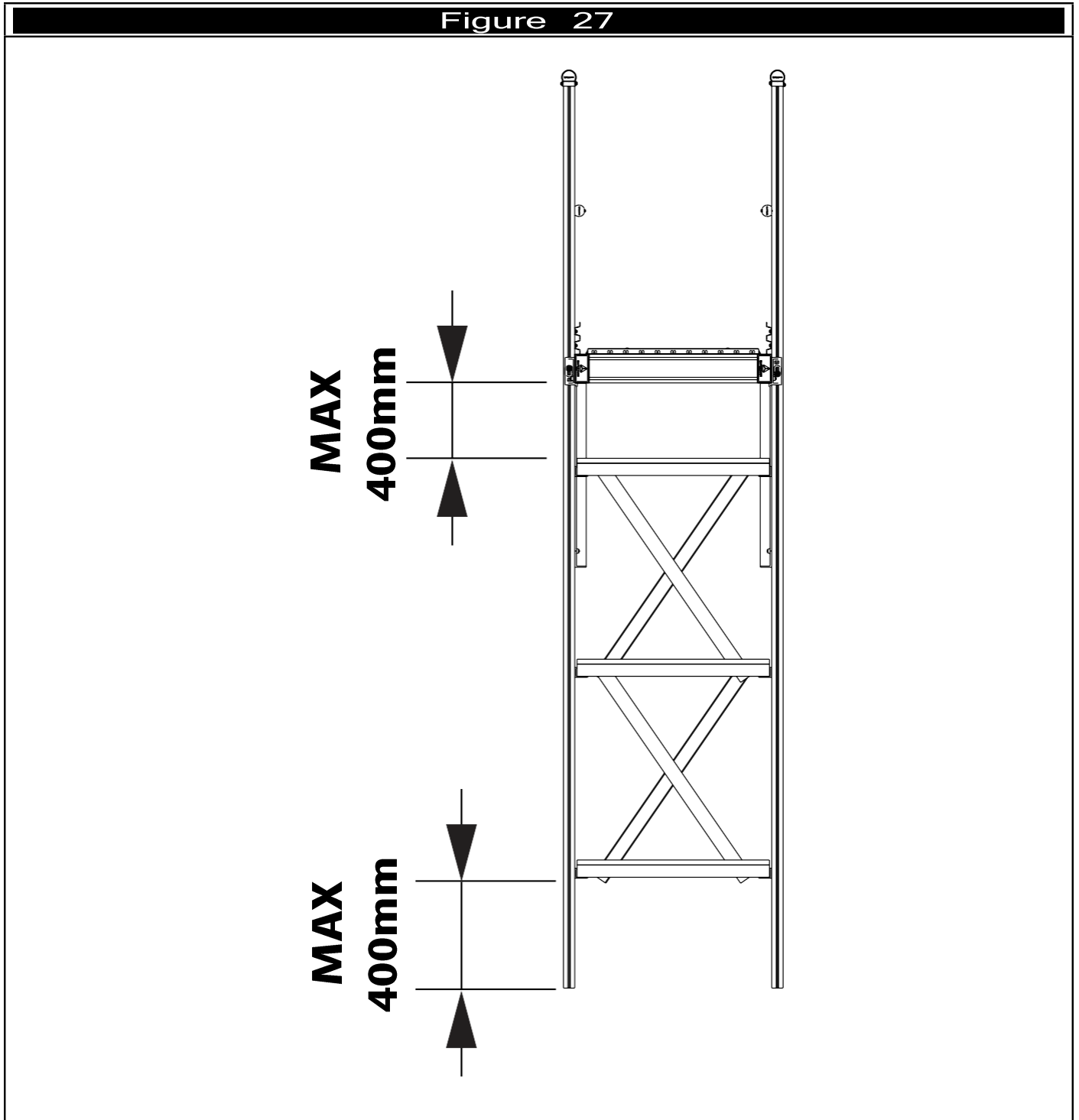

### 3.2 System Requirements

The following requirements are mandatory for Compliance with the AS1657:2018.

#### 3.2.1 Guardrail Height

- I The guardrail height shall be not less than 900mm above the surface of the walkway.
- II If the guardrail is greater than 1065mm above the surface of the walkway, another intermediate rail shall be installed.

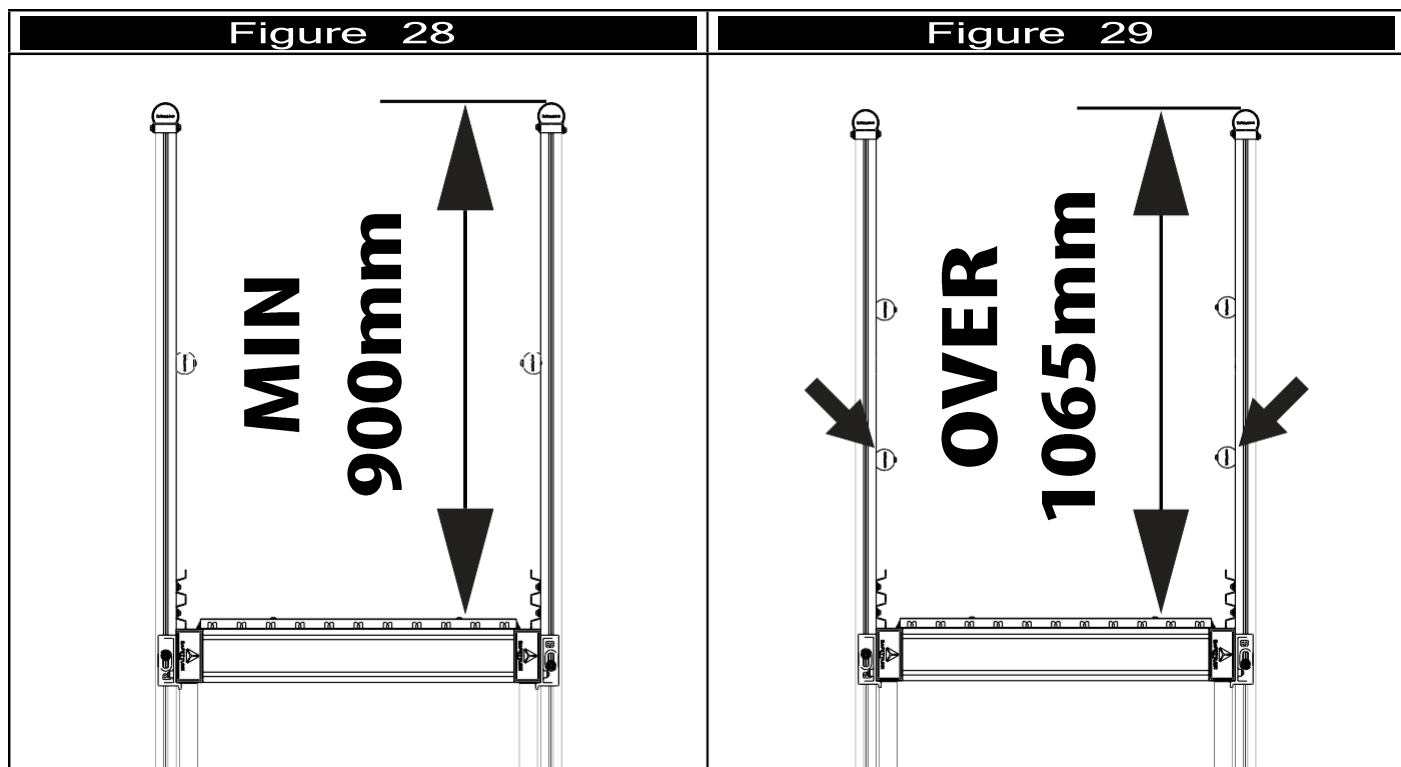

#### 3.2.2 Platform Width

- I The platform shall be at least 600mm wide
- II The clearance between guardrail components shall be not less than 550mm

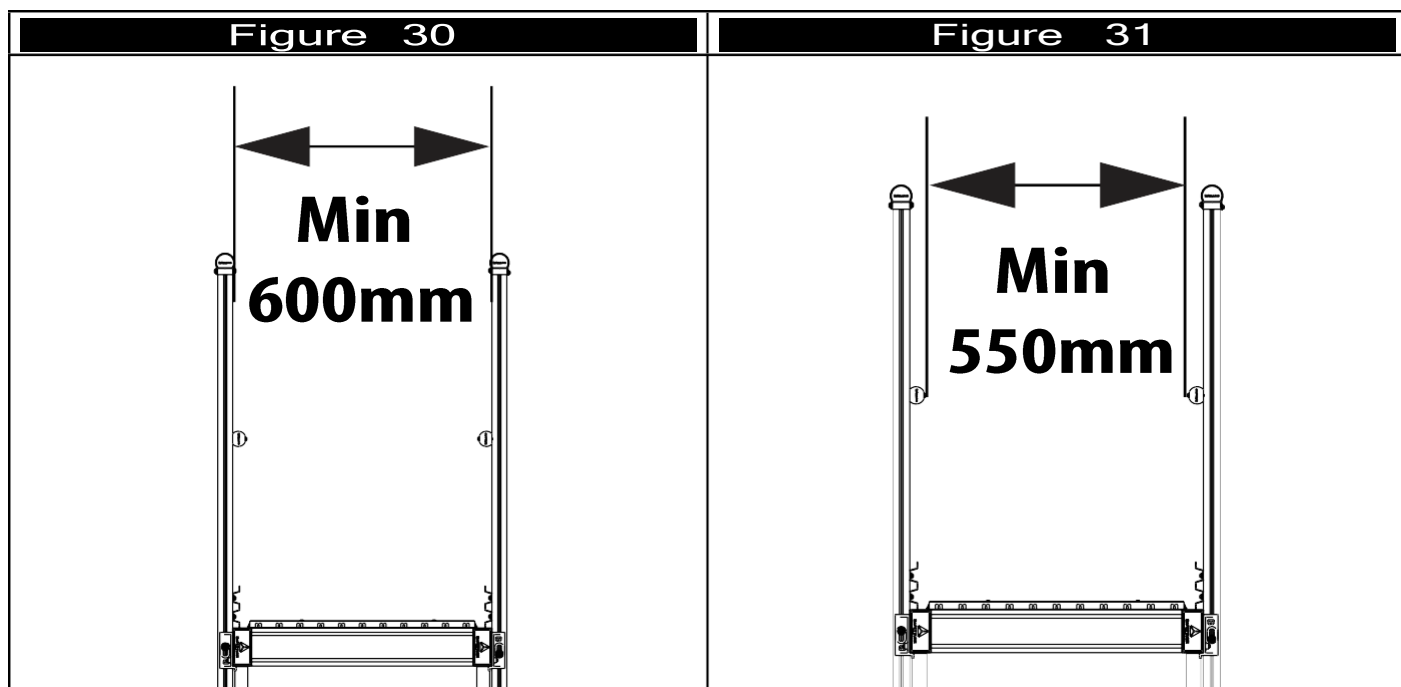

### 3.2.3 Hand Clearance

- I There shall be a minimum of 50mm clearance around the handrail.

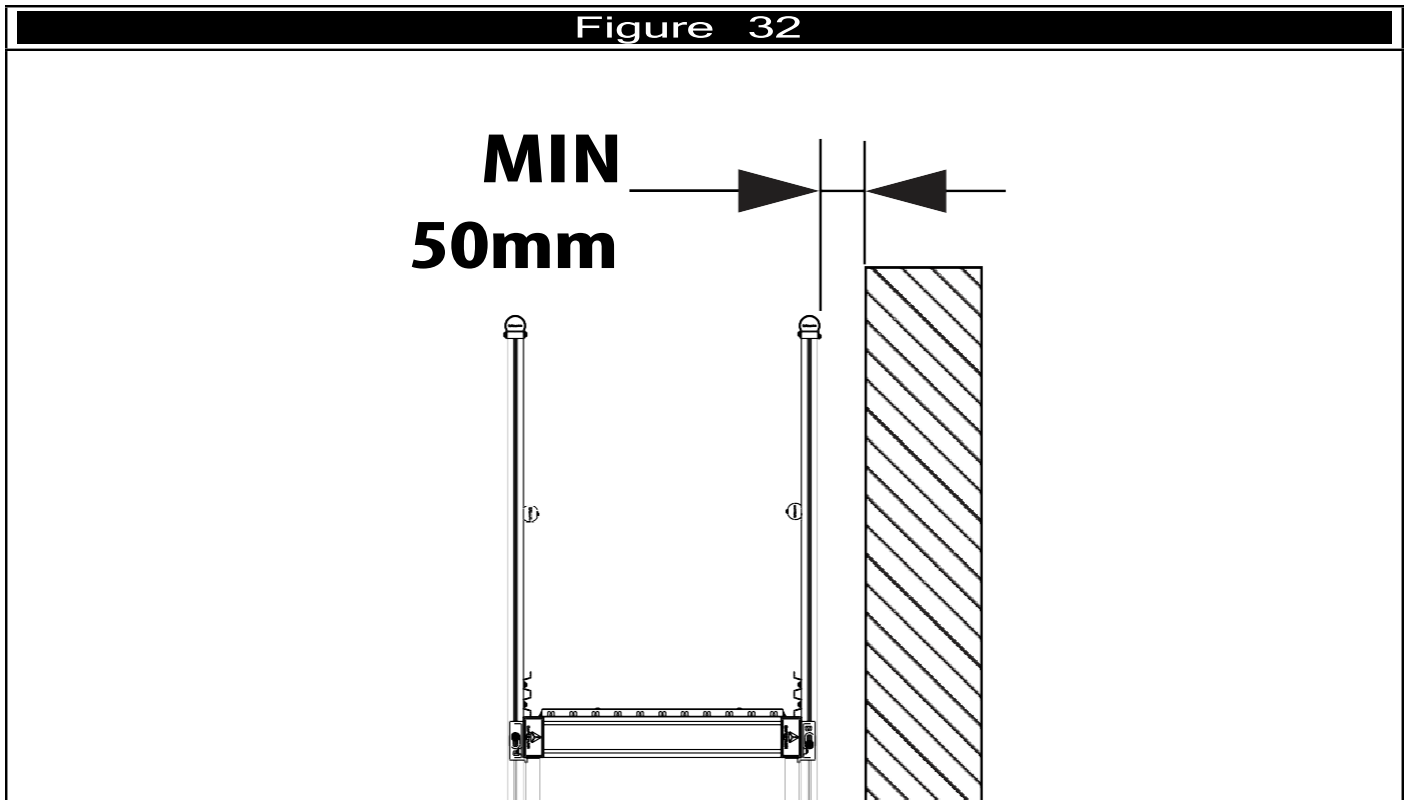

### 3.2.4 Toeboard

- I Toeboards shall be installed on the edge of walkways where there is the risk that an object could fall to where people have access to the area below.

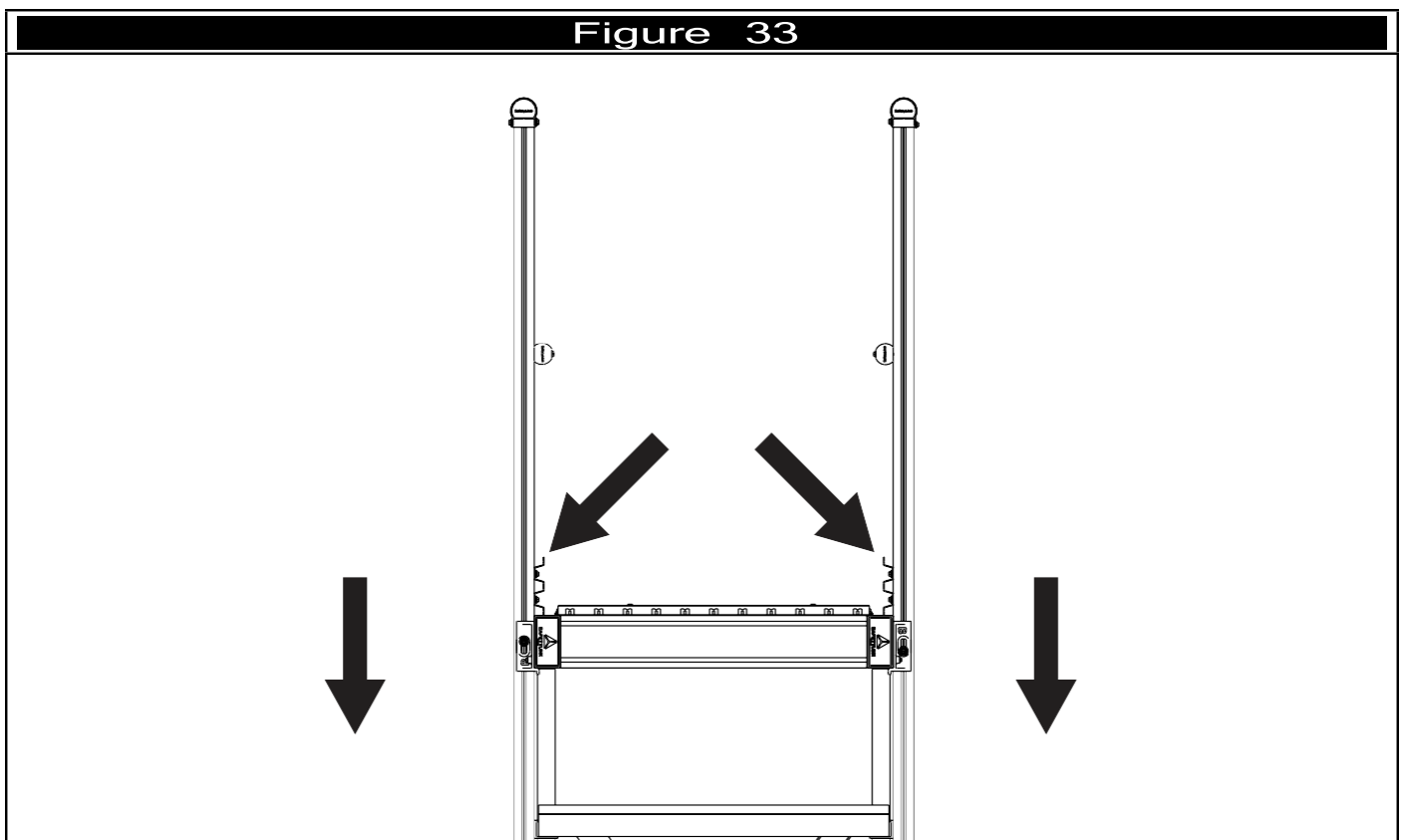

### 3.2.5 Rail Spacing

- I The distance between the top and middle rail cannot be less than 450mm.
- II The distance between the middle rail and the walkway surface cannot exceed 560mm.
- III Where a toeboard is installed the distance from the middle rail to the toeboard shall not exceed 450mm.

Figure 34

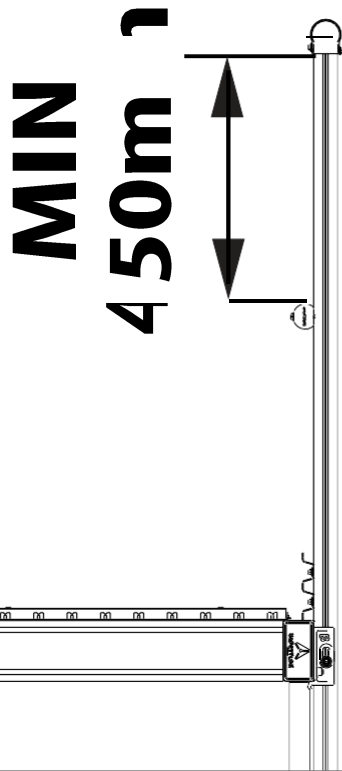

Figure 35

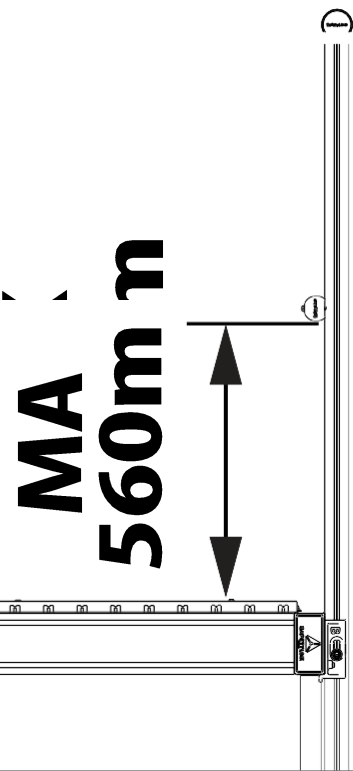
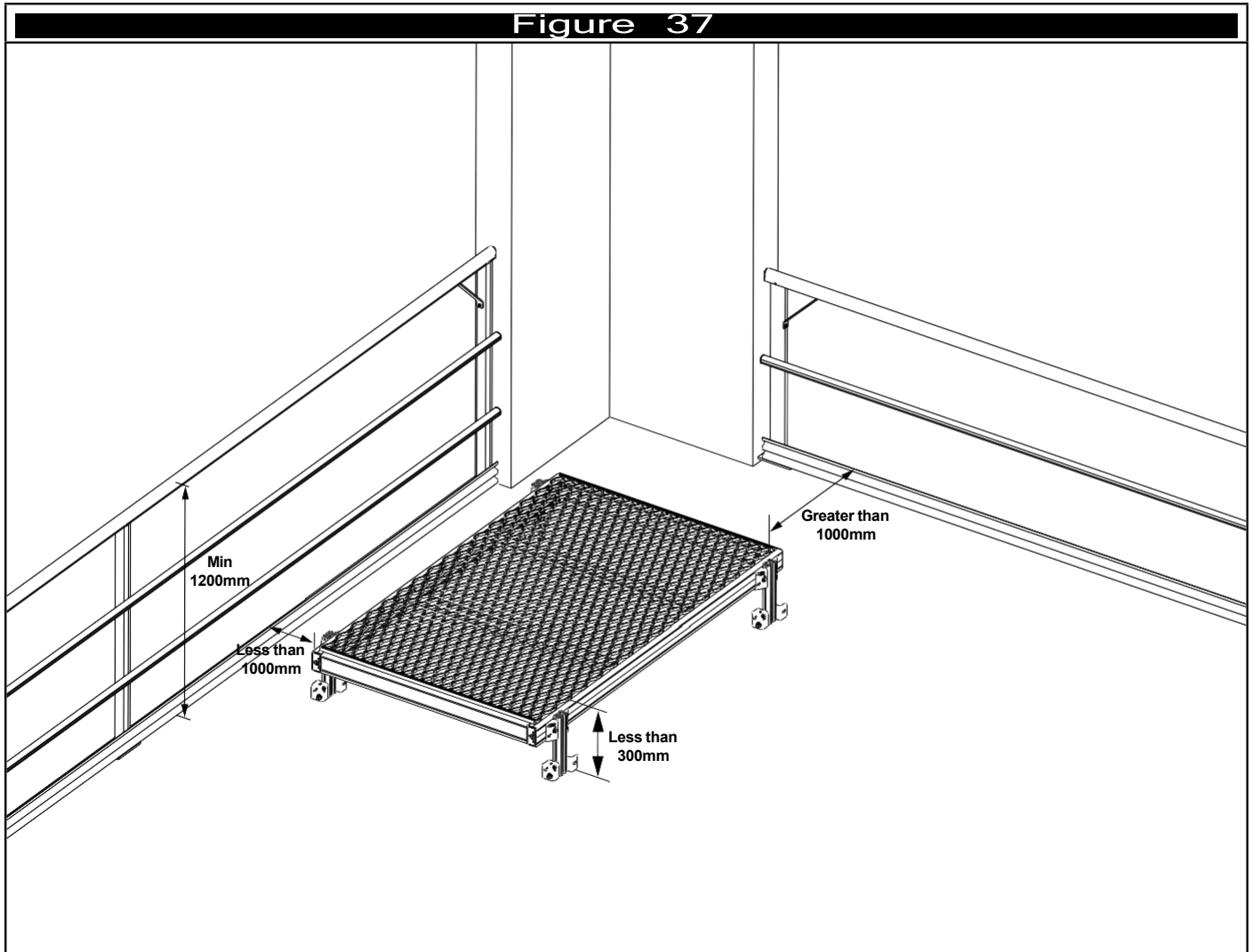

Figure 36



### 3.2.6 Platform Guardrailing

- I Guardrailing is not required around a platform if the height to the lower walking surface is less than 300mm and the distance to an existing guardrail is more than 1000mm.
- II Where the distance to an existing guardrail is less than 1000mm, the guardrail height must be increased by 300mm.



### 3.3 Fasteners

#### 3.3.1 Hex Head Screws

All M8 hex screws are stainless steel 316. All shall be tightened to 20Nm with a 13mm Socket, C or ring spanner.

#### 3.3.2 T-Bolt

All M8 T-bolts are stainless steel 316. All shall be tightened to 20Nm with a 13mm Socket, C or ring spanner.

⚠ **Ensure the indicator line is in the correct orientation as shown in Figure 38. The indicator line shall be perpendicular to the T-Slot in the extrusion of which it is installed.**

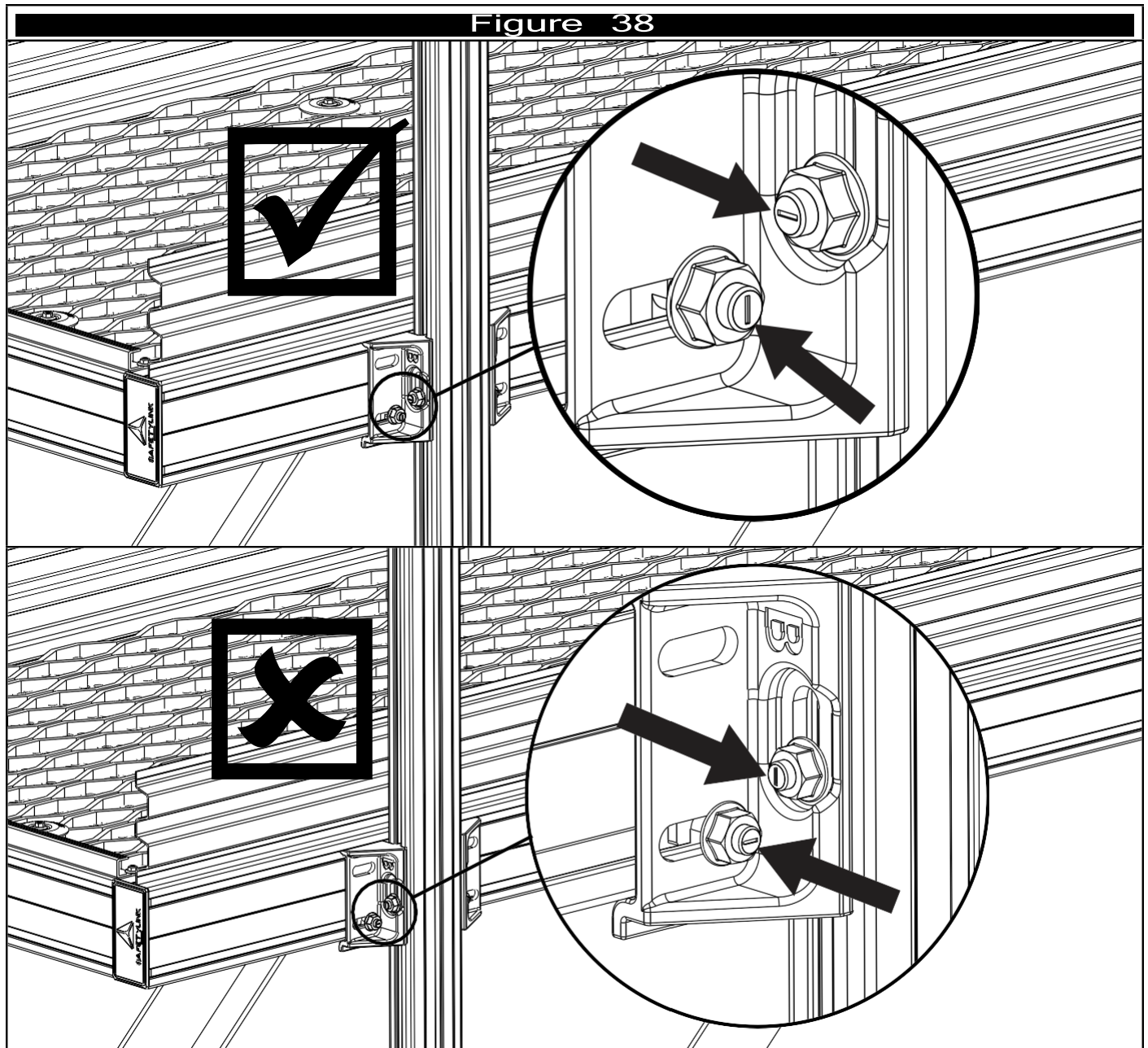

#### 3.3.3 Tek Screws

All supplied Tek Screws are 12 gauge hot dip galvanised hi tensile steel. All are to be installed with a 3/8" drive socket.

#### 3.3.4 Rivets

To fix the system to roof structures, 8mm aluminium trifold rivets shall be used.

### 3.3.5 Label

All systems shall be marked with the label shown in Figure 39. The label shall be filled out by the installer and fixed with 2 x 5.2mm trifold rivets.

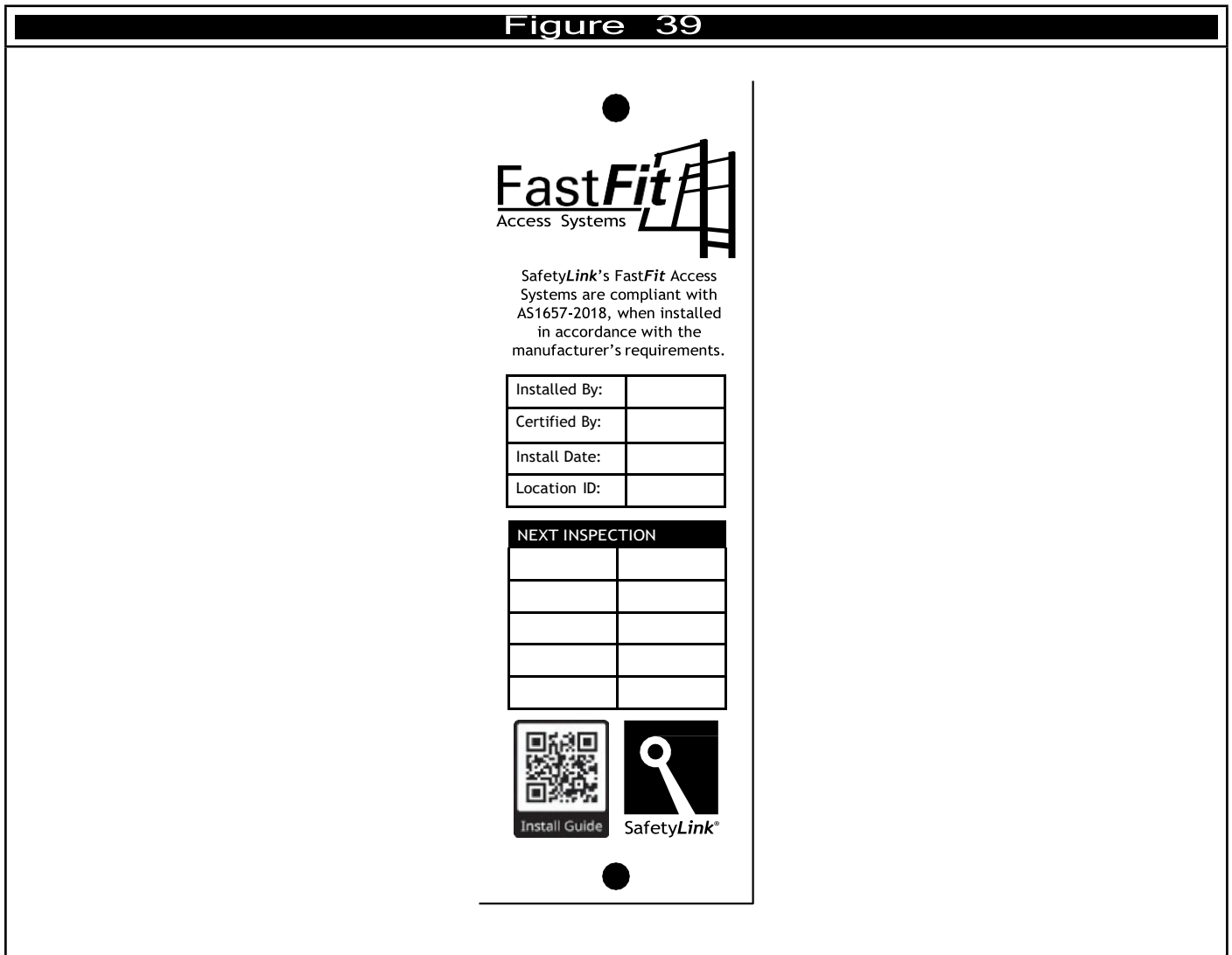

### 3.3.6 SafetyLink Concrete Fastener

SafetyLink's M10 Concrete Stud CON-M10X130 is to be installed with chemical adhesive CON-CHEM-FISV.300.

1. Mark the location for the hole.

⚠ ***The location shall be no less than 150mm from any edge.***

⚠ ***The concrete shall measure not less than 150mm thick.***

⚠ ***The stud shall only be installed in crack free concrete 32MPa or greater.***

⚠ ***Consult a structural engineer if there is any doubt of the suitability of the structure.***

2. Set the drill depth to 95mm and drill a 12mm diameter hole.

3. Clean the hole, ensuring it is free of moisture and dust.

4. Inject the adhesive in to the hole as per the manufacturer's instruction.

5. Insert the stud to full depth, 35mm of the stud should remain above the surface. Wipe away any adhesive expelled from the hole.

⚠ ***Ensure enough adhesive was used, the adhesive should finish flush with the concrete.***

6. Once the adhesive is cured, install the spring washer and tighten the nut to 20Nm.

### 3.3.7 Third Party Concrete Fasteners

Other suitable concrete fasteners are listed below. Fasteners of equivalent strength to that listed below may be used. All fasteners shall be installed in accordance with the manufacturer's requirements.

I Fischer FAZ II minimum M10 x 55 (Expansion Bolt)

II Fischer FH II minimum M10 x 70 (Expansion Bolt)

III Fischer ULTRACUT US FBS II minimum M10x85 (Concrete Screw)

## 4 Brackets

Section 4 describes how to install one of each of the fixing brackets, how many and the types of fastener required for each bracket. When assembling platforms, staircases and the supporting structures, the number of each bracket required and the installation location is defined in sections 5 to 7.

### 4.1 Stair Bracket (A)

1. Hook the bracket into the platform extrusions' top T-slot and fix with 2x T-bolts through the bracket into the lower T-slot of the platform extrusion.
2. Place the stair tread in the bracket and fix with 4x T-bolts.

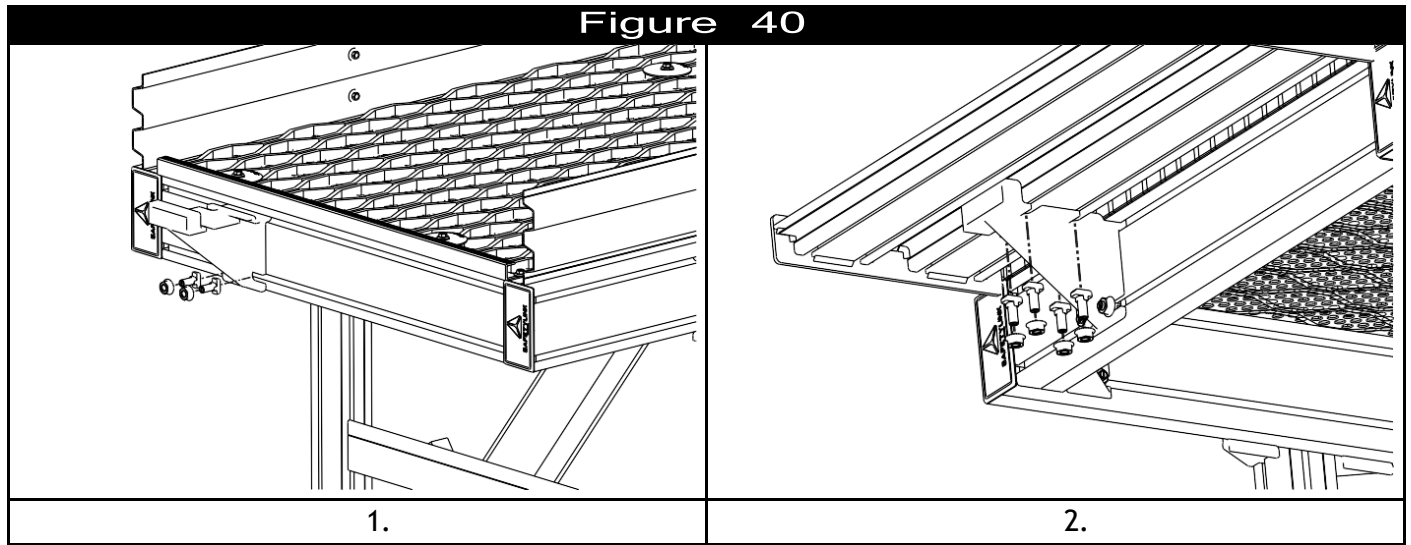

### 4.2 Post Bracket (B)

1. Hook the bracket into the platform extrusions' top T-slot and fix with 1x T-bolts through the bracket into the lower T-slot of the platform extrusion.
2. Place the post extrusion in the bracket and fix with 1x T-bolts.

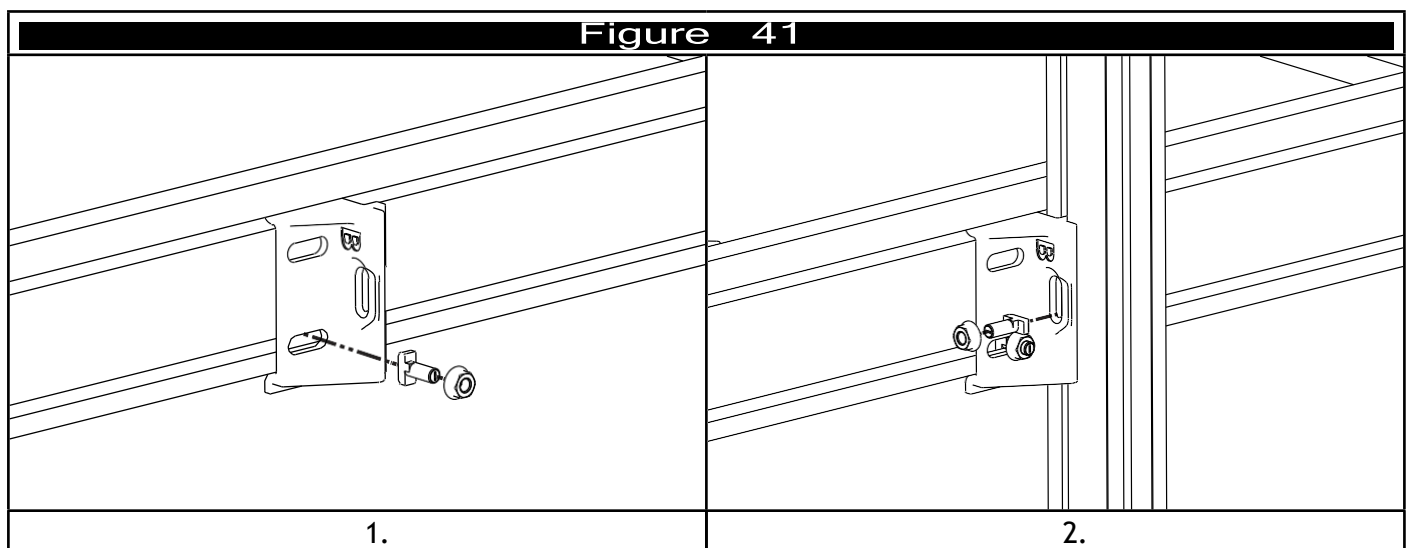

### 4.3 Corner Bracket (C)

1. Place the bracket on the platform extrusion and align it with the end of the extrusion (or in the desired location).
2. Install 2x T-bolts through the bracket in to the T-slots of the platform extrusion.
3. Place the second piece of platform extrusion on the other side of the bracket and align the end as needed to form a corner.
4. Install 2x T-bolts through the bracket in to the T-slots of the platform extrusion.

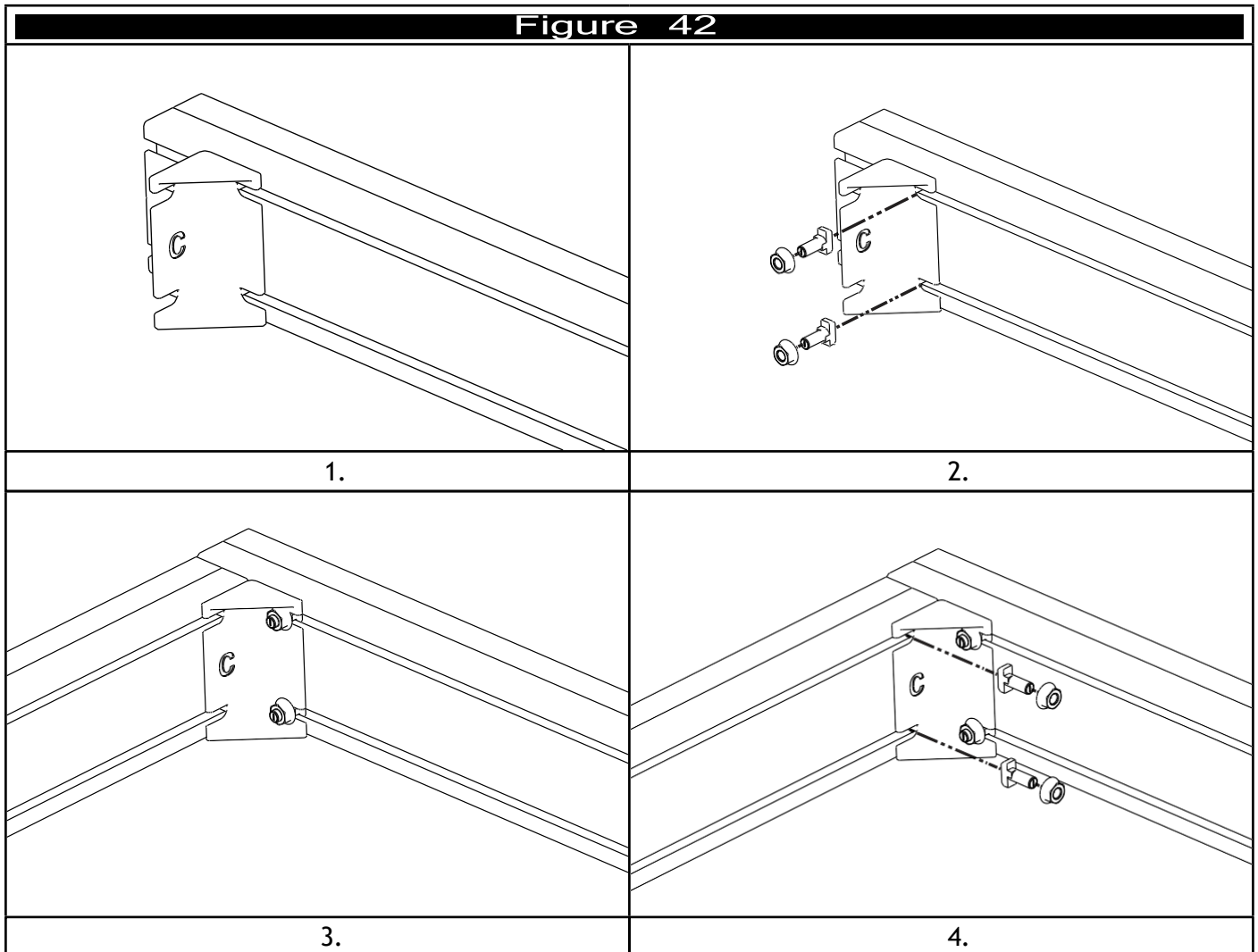

#### 4.4 Stair Post Bracket (D&H)

1. Install the hex screw into the D bracket.
2. Hook the D bracket in to the top stringer extrusions' T-slot and fasten with 1x T-bolt.
3. Place the post extrusion beside the D bracket and install the H bracket capturing the hex screw.
4. Install a nut on the hex bolt and fix the H bracket in place with 1x T-bolt.

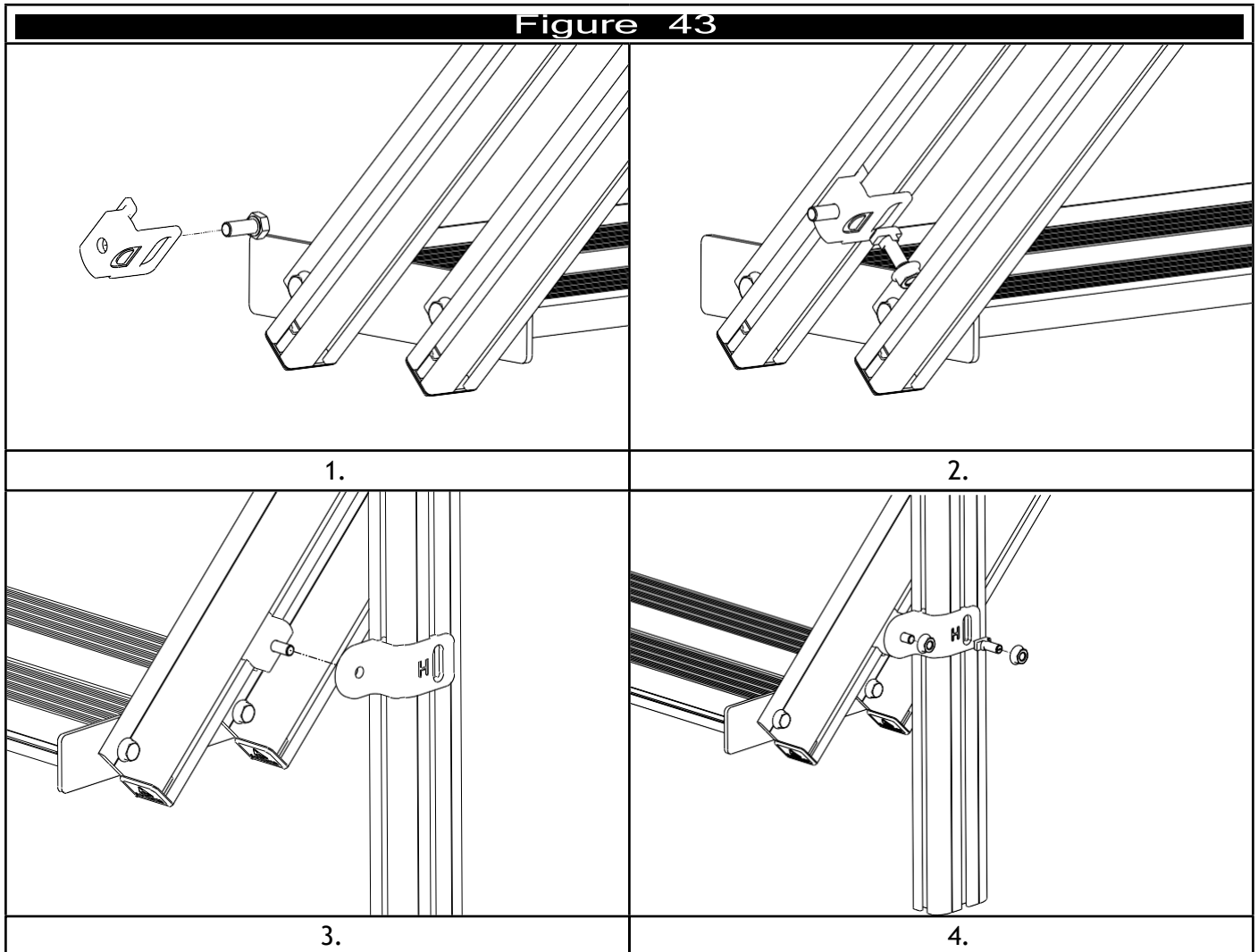

#### 4.5 Mesh Support Bracket (E)

1. Hook the bracket in to the platform extrusions' top T-slot.
2. Place the mesh support extrusion in the bracket and fix with 1x T-bolt.

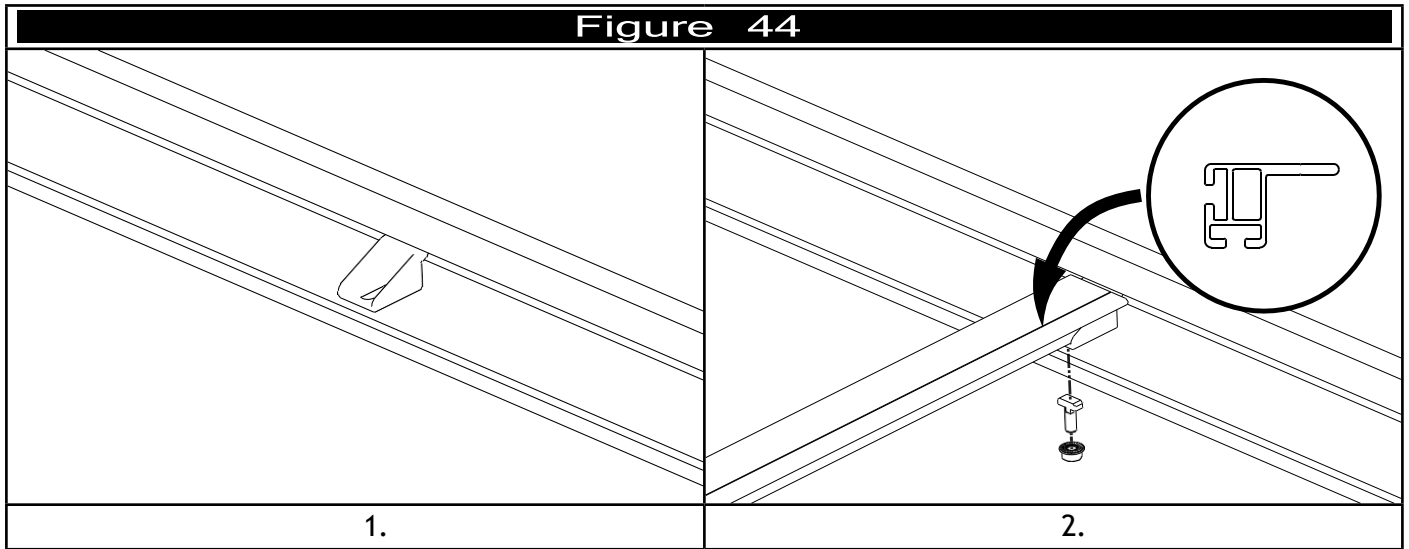

#### 4.6 Concrete Foot Bracket (F)

1. Align the teeth of the bracket with the T-slot of the post extrusion profile.
2. Install 1x T-bolt through the bracket in to the T-slot of the extrusion and tighten till the bracket pulls in.
3. Install a concrete fastener as per sections 3.3.6 or 3.3.7.

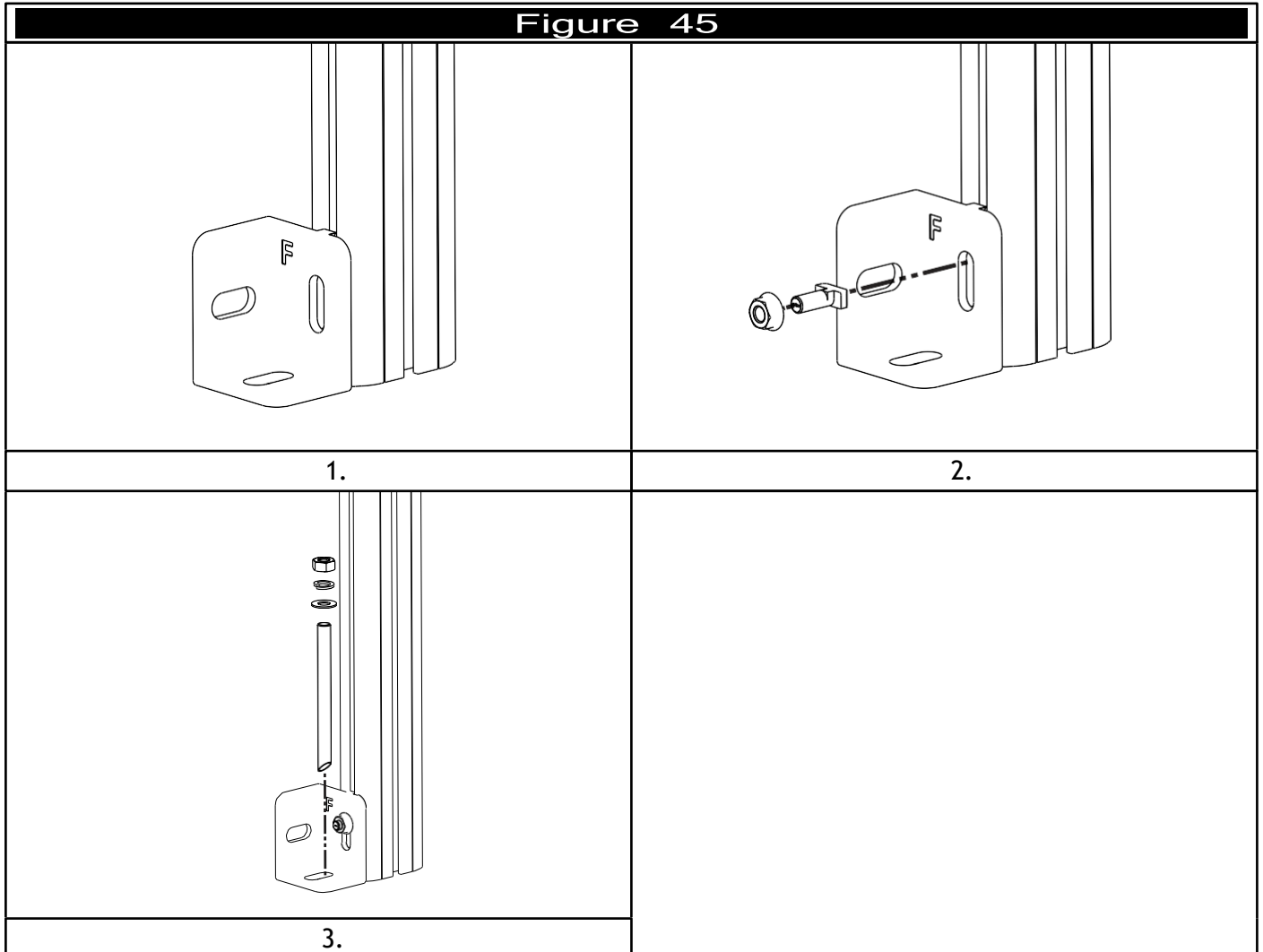

#### 4.7 Lateral Brace Bracket (G&H)

1. Hook the H bracket into the post extrusions' T-slot and fix with 1x T-bolt.
2. Install brace extrusion in the G bracket and fix the G bracket to the H bracket with the hex head screw.
3. Ensure the brace material extends past the edge of the post.
4. Install the brace end cap.

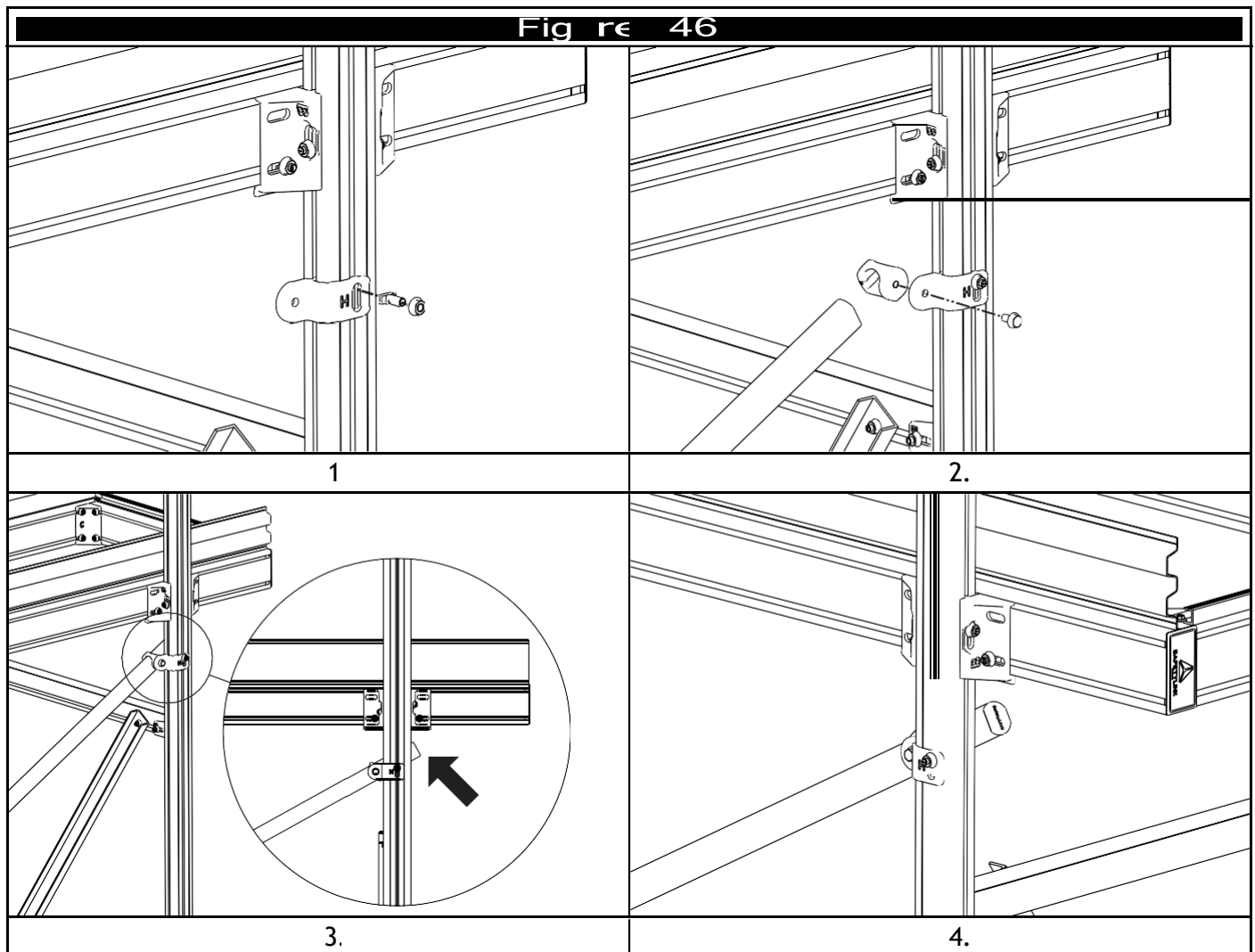

#### 4.8 Clip Bracket (I)

1. Hook the bracket into the platform extrusions' bottom T-slot.
2. Fix in to the support with 1x T-bolt.

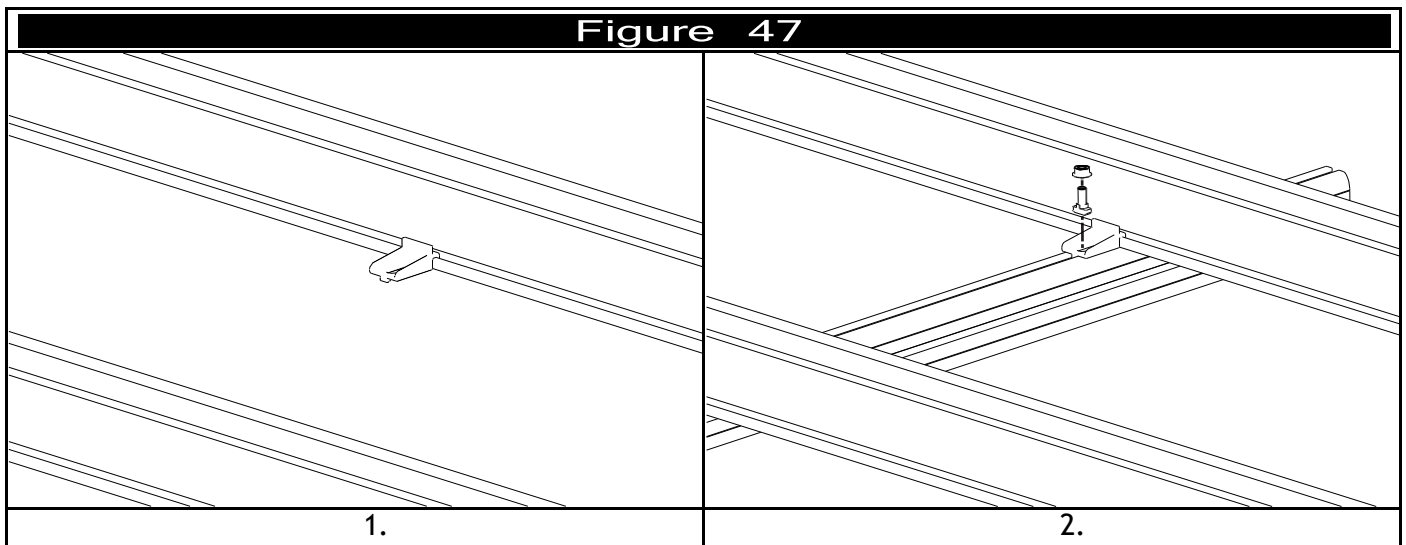

#### 4.9 Platform Splice (J)

1. Fix the plate of the splice to the first platform extrusion with 4x T-bolts.
2. Slide the square section into the platform extrusion and fix with 2x 12g tek screws.
3. Slide the second platform extrusion onto the square section and fix with 2 12g tek screws.
4. Fix the plate to the second platform extrusion with 4x T-bolts.

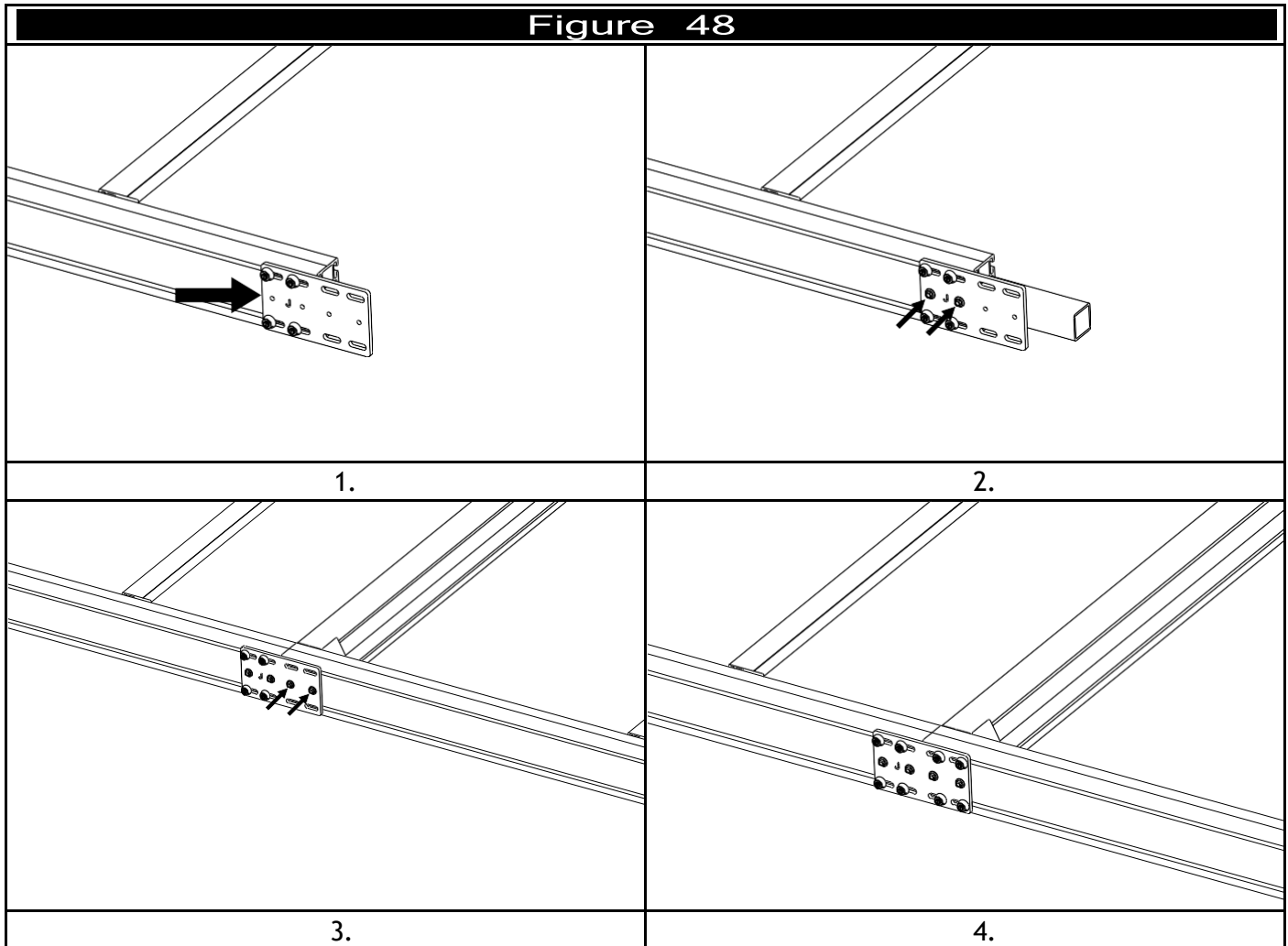



## 5 Platforms

### 5.1 Outer Frame (Single Section)

1. Assemble the frame with 4x lengths of platform extrusion and 4x corner brackets (C).
2. Install 4x platform end caps in the end of the extrusion.

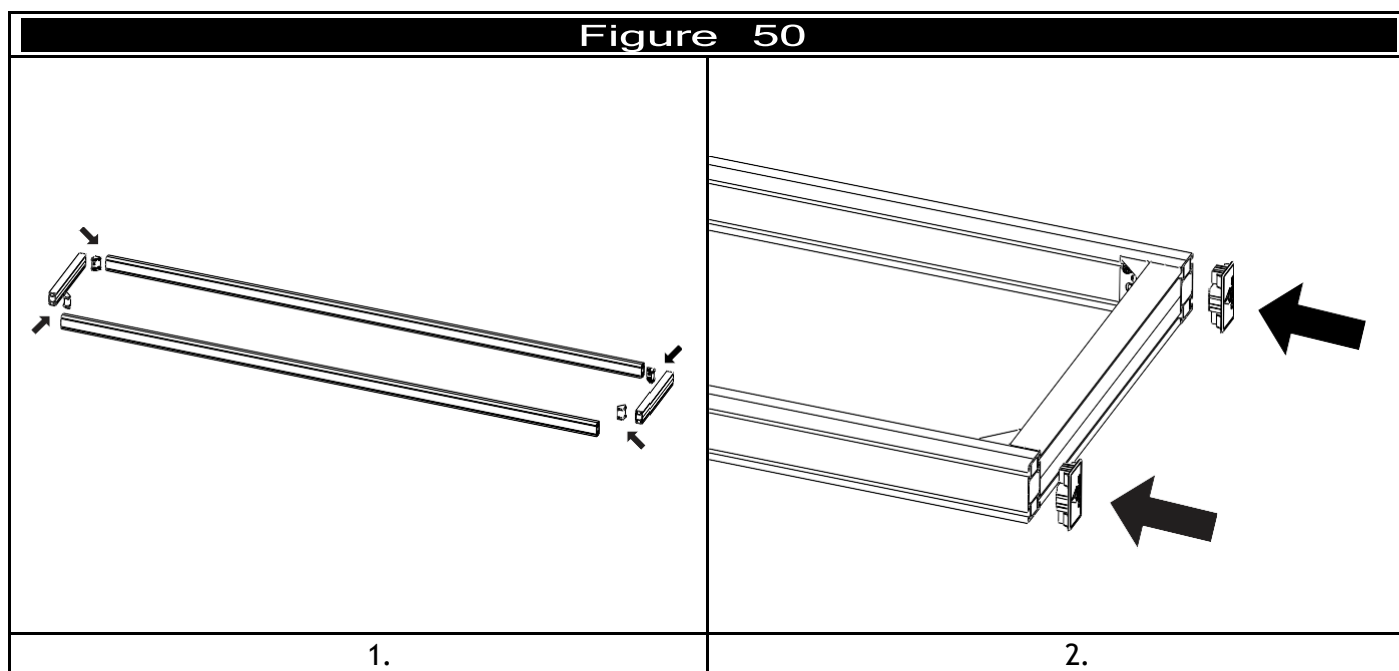

### 5.2 Outer Frame (Multiple Sections)

1. Add sections to an outer frame by adding 3x lengths of platform extrusion and 4x corner brackets (C).
2. Install 2x platform end caps in the end of the extrusion.

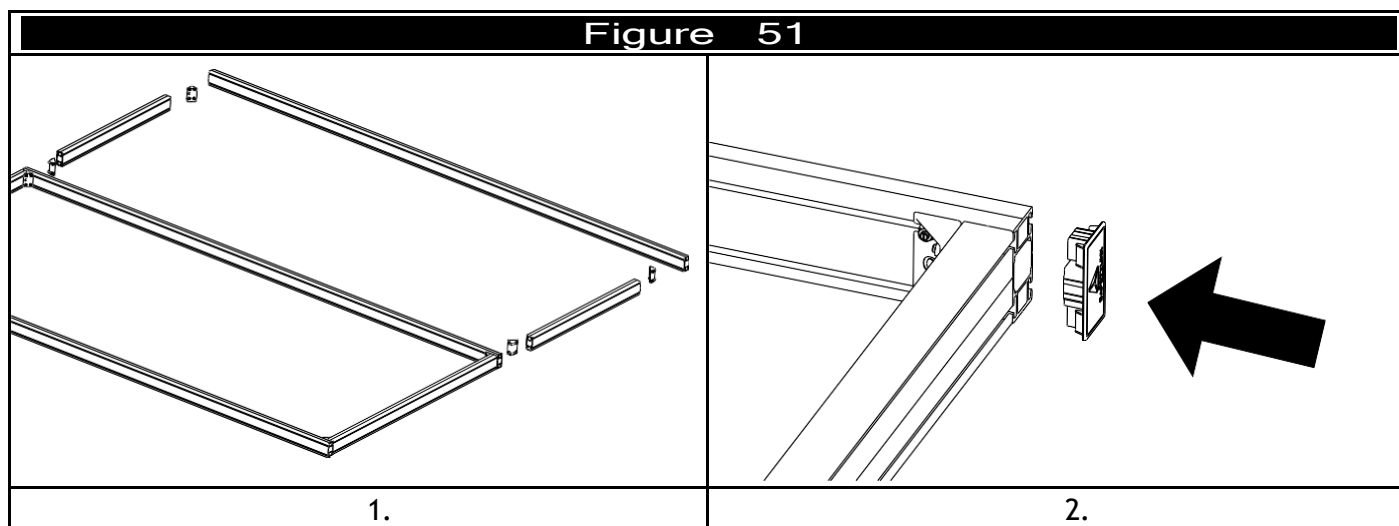

### 5.3 Frame Support

1. Every 2m, in each section of the frame, install a frame support using the platform extrusion length.
2. Install 1x platform extrusion length with 2x corner brackets (C).

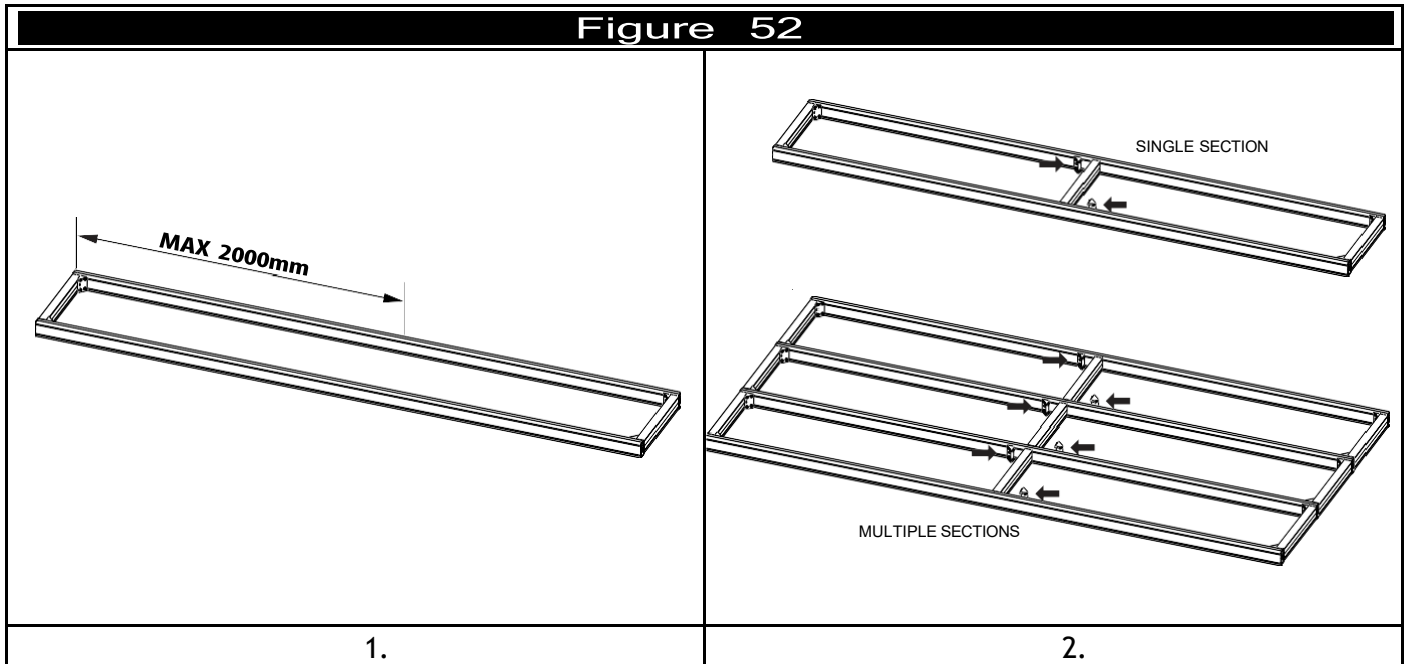

### 5.4 Mesh Support Battens

1. In every section at a maximum of 700mm install a mesh support.
2. Install 1x mesh support length with 2x mesh support brackets (E).

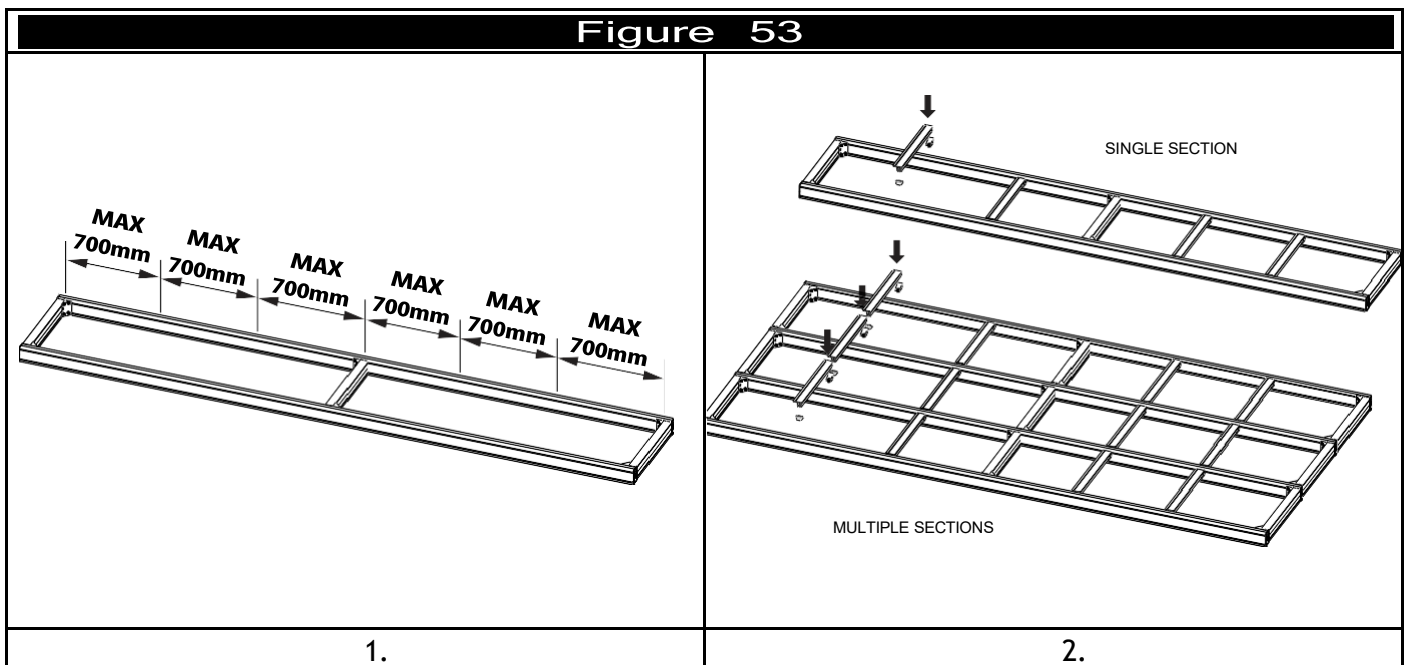

## 5.5 Platform Frame T and L Junctions

1. Platforms can be joined in a T or L shape with the length extrusions of each platform at 90° to one another. For this instruction, the Main platform below remains unmodified and the Joining platform is attached to it.

**⚠ This method should not be used to make platforms with multiple sections of different lengths with all the length extrusions in the same direction. See Sections 3.1.8 and 5.2**

2. Remove the end platform extrusion and slide the 2 corner brackets (C) to the end of the length extrusions.
3. Fix the Joining platform to the Main platform with the 2 corner brackets (C).
4. If the gaps between the mesh support batten can not be manipulated to be less than 700mm, re install the removed platform extrusions with 2 corner brackets (C)
5. If the gap between the support structures on the main platform and every length extrusions of the joining platform is not greater than 200mm, the joining platform does not require its own support at the joining end.
6. The mesh shall be installed in the same direction as the length extrusion for each platform.

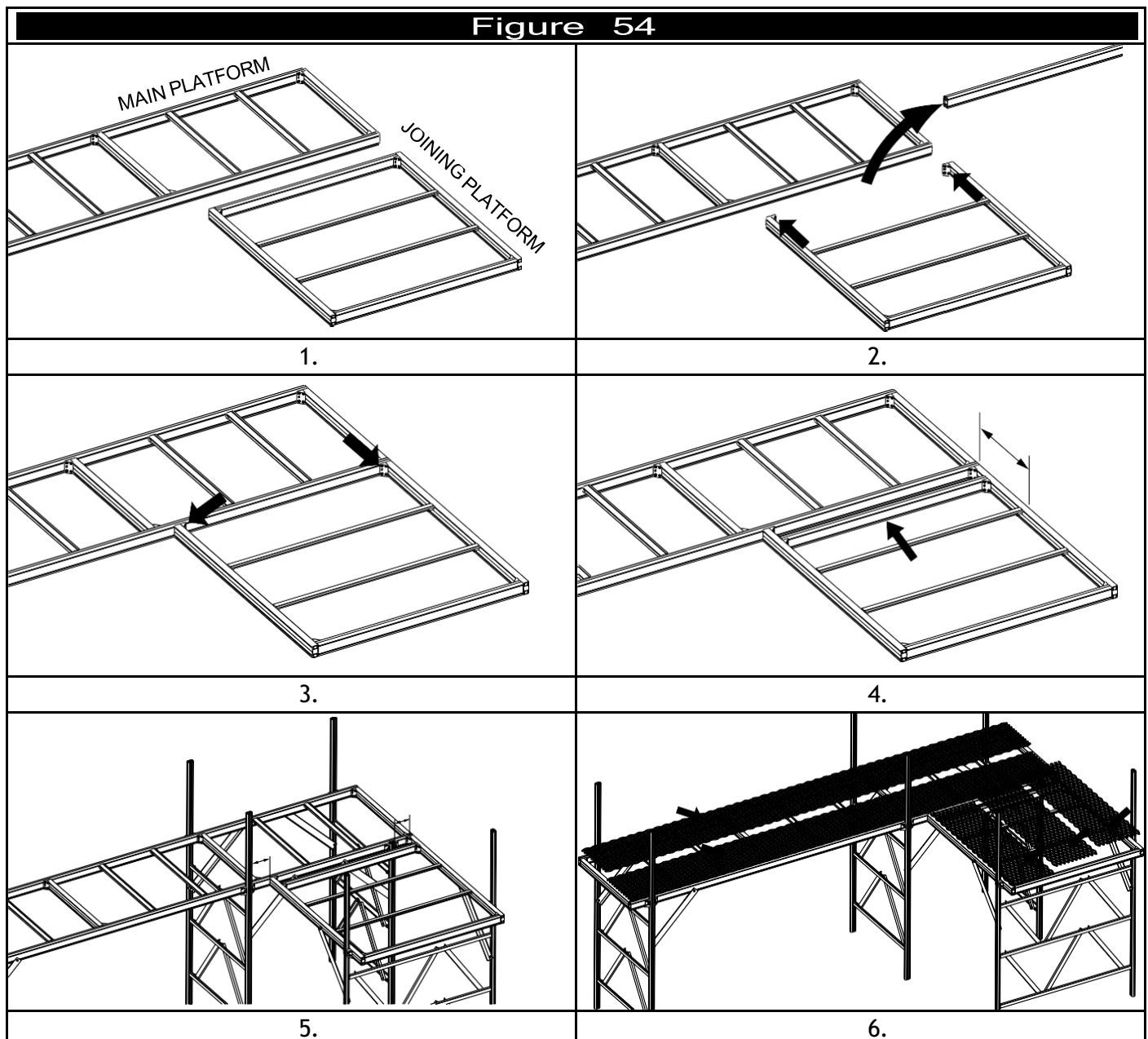

## 5.7 Mesh Fastening

- ☑ The mesh can be fastened to the frame before or after leveling it on the platform supports as per section 6.
1. Walkway mesh shall be fixed with 2x 35mm tek screws in to each mesh support batten and frame support. Each screw shall be installed with a 50mm aluminium walkway mesh washer.
  2. For platforms where people will be working below, dropped object mesh can be install below the mesh by sitting it below the mesh before fixing to the battens.

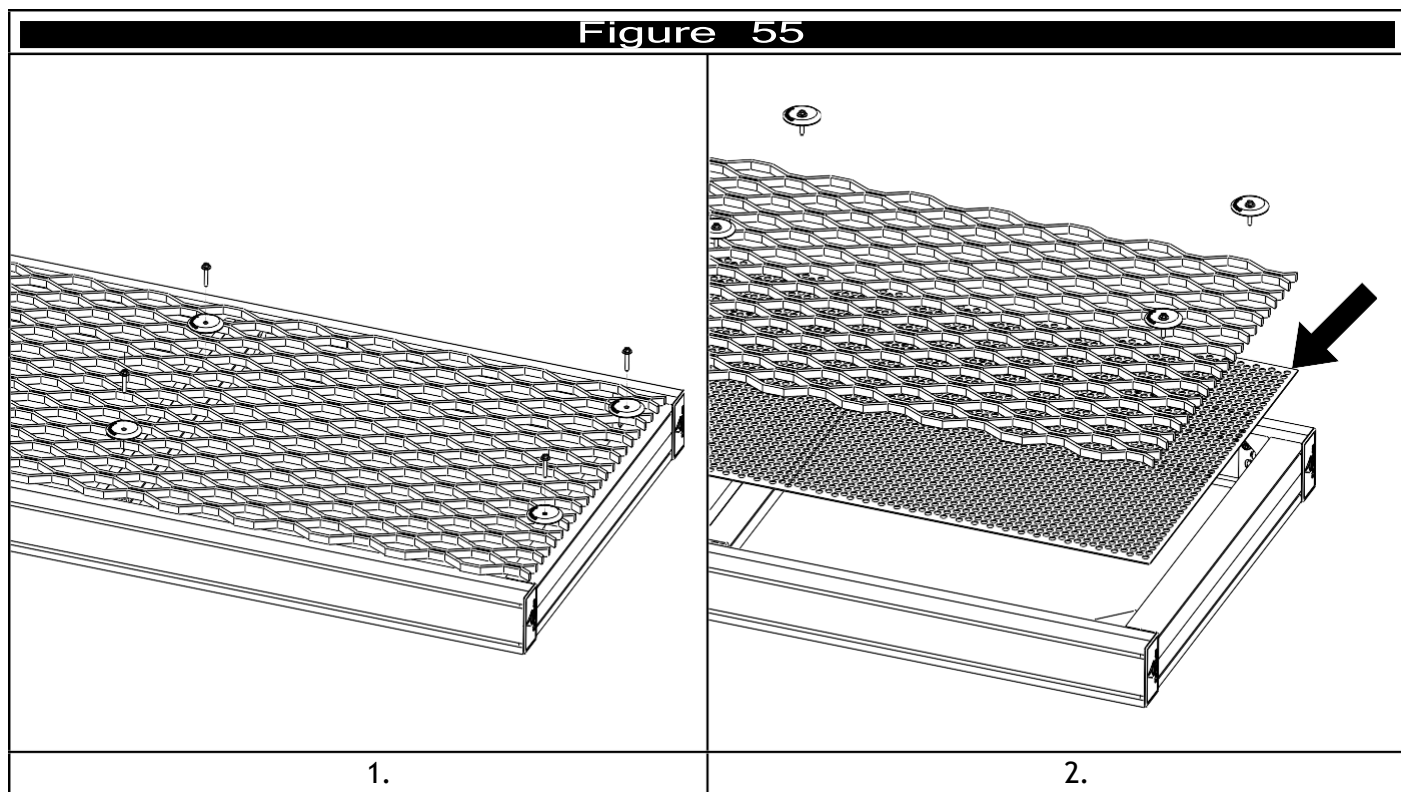

## 5.8 Mesh Joins

1. When joining 2 sheets of walkway mesh, the joiner bar shall be installed with 2x 20mm tek screws in to each piece of mesh.

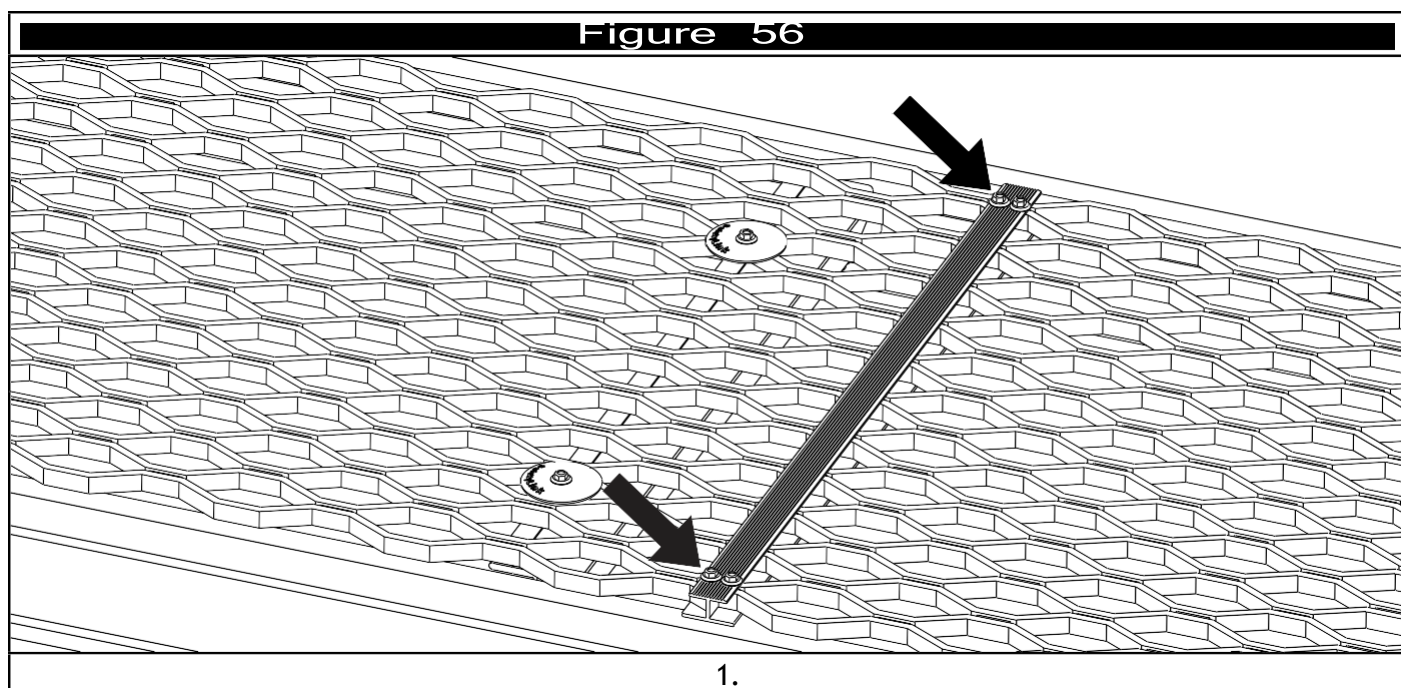

## 5.9 Mesh Ends

1. The end of a sheet of walkway mesh shall be capped with an end bar. The end bar shall be fixed with 2x 20mm tek screws.

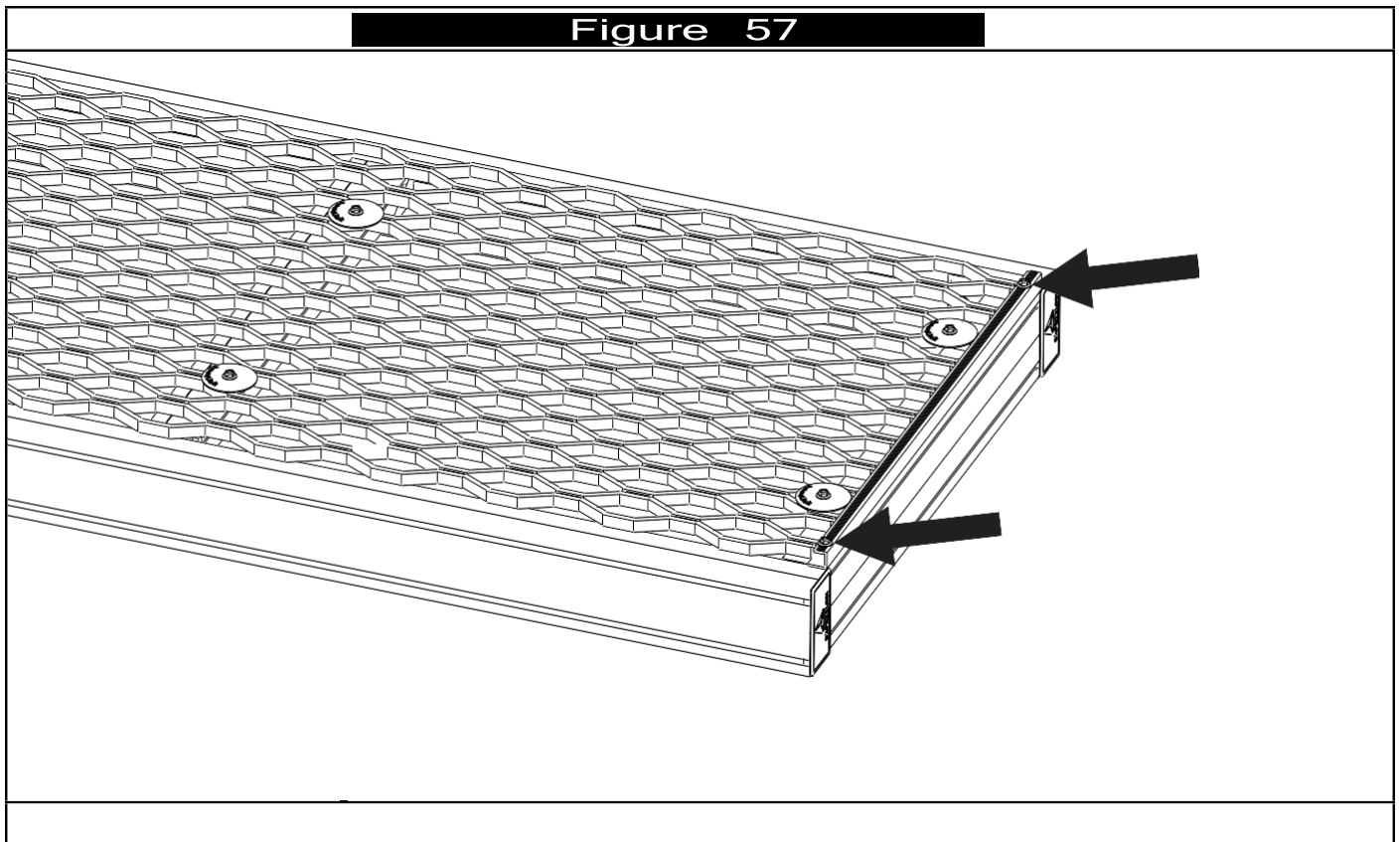

1.

## 5.10 Platform Single Post

1. Install the post bracket (B) in the desired location.
2. Install the post with at least 860mm of material above the platform. (875mm if no mesh is installed) The post must extend past the bottom of the bracket.
3. Install a second post bracket (B) on the other side of the post.
4. Fit the cap to the base of the post.

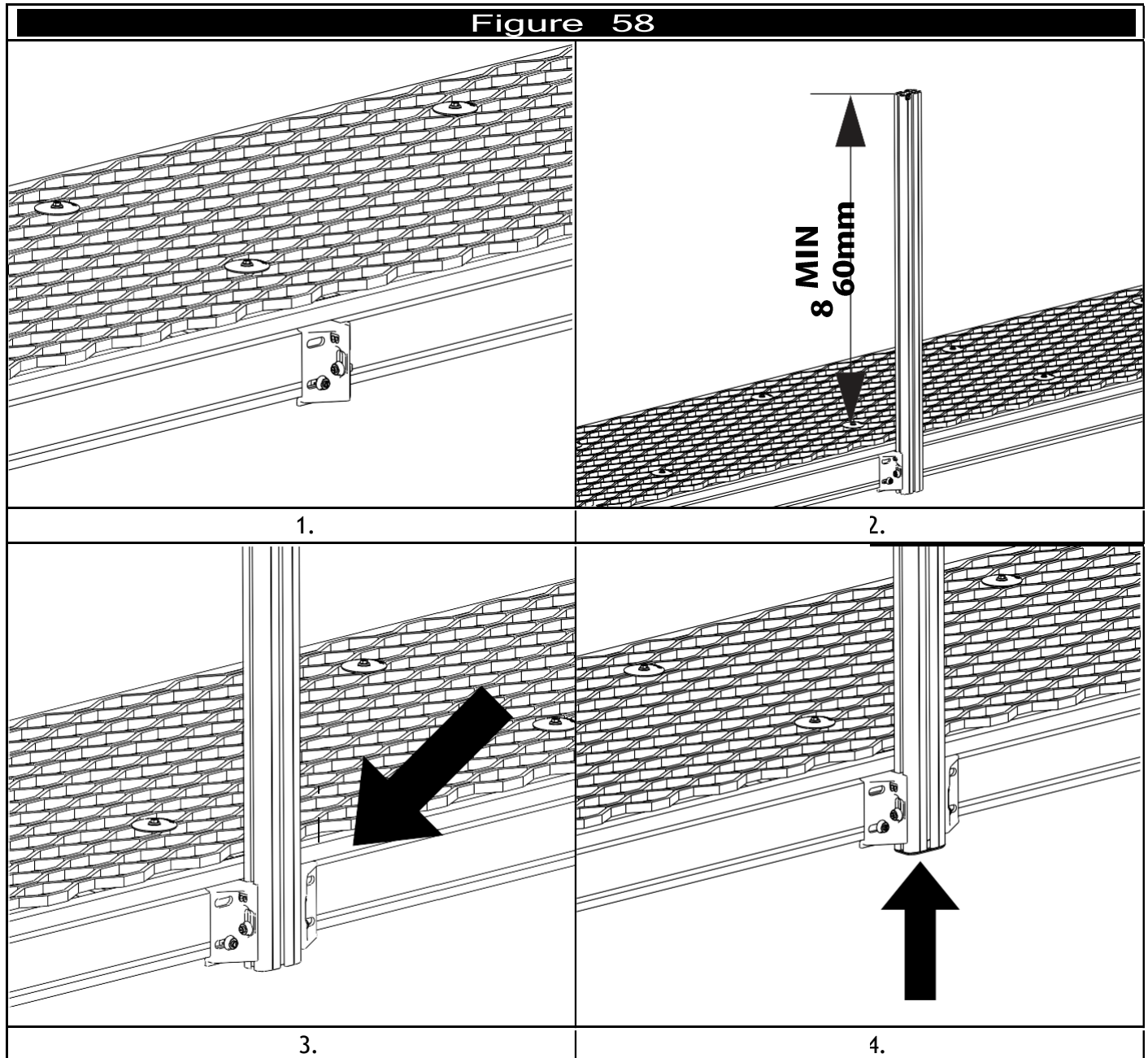

## 6 Platform Supports

### 6.1 Posts

1. Install the first post bracket (B) and fix the post with at least 875mm of material above the platform frame surface. (860mm if the mesh is installed).
2. Fix a second post bracket (B) on the other side of the post.
3. Repeat the process with a second post on the other side of the platform.

Figure 59

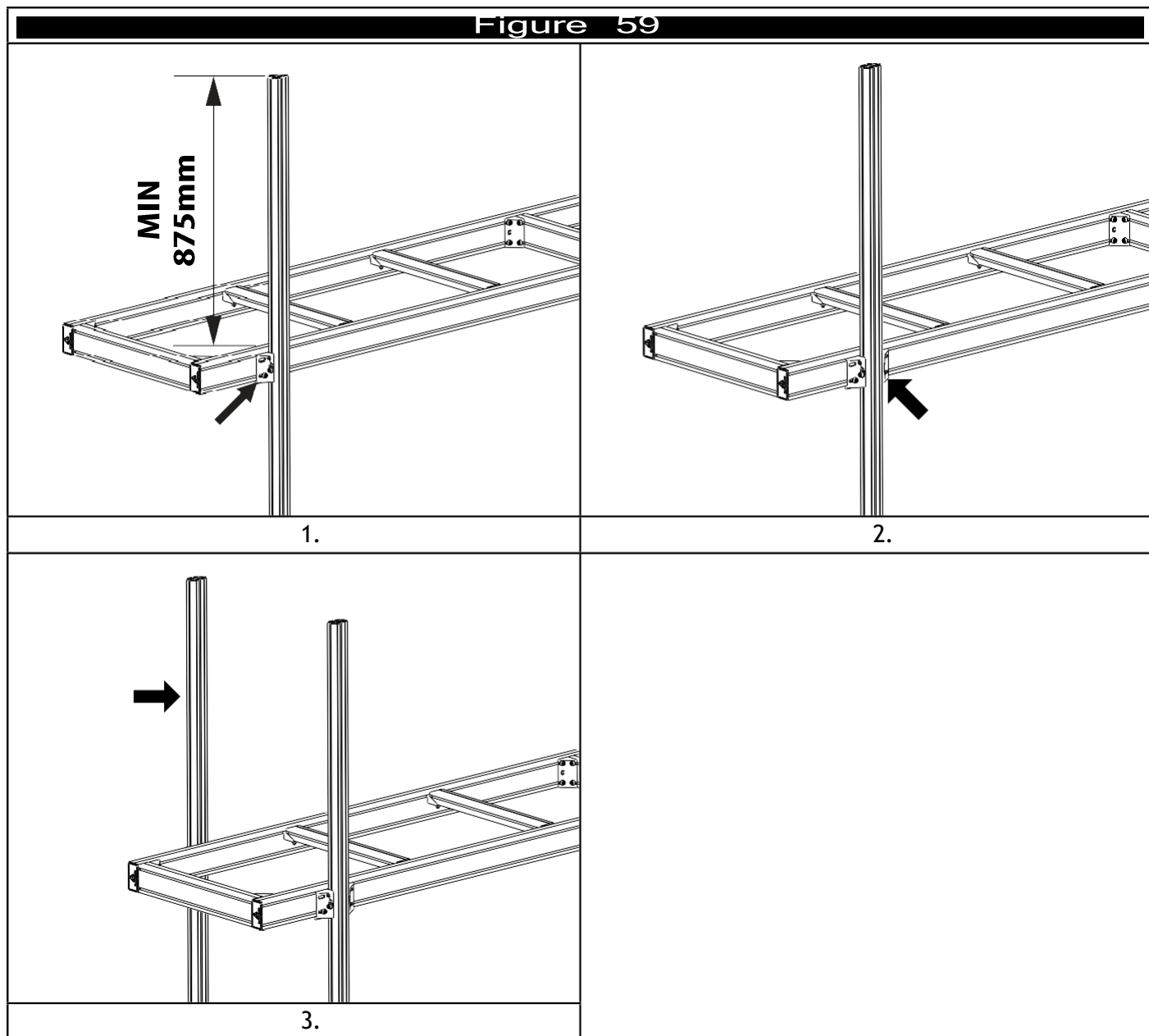

## 6.2 Horizontal Brace

1. Install the first horizontal brace not greater than 400mm from the end of the post. See section 3.1.18 for details.
2. Install the brace with 2x mesh support brackets (E).
3. Where diagonal support braces are required, install another horizontal brace 700-720mm from the first.

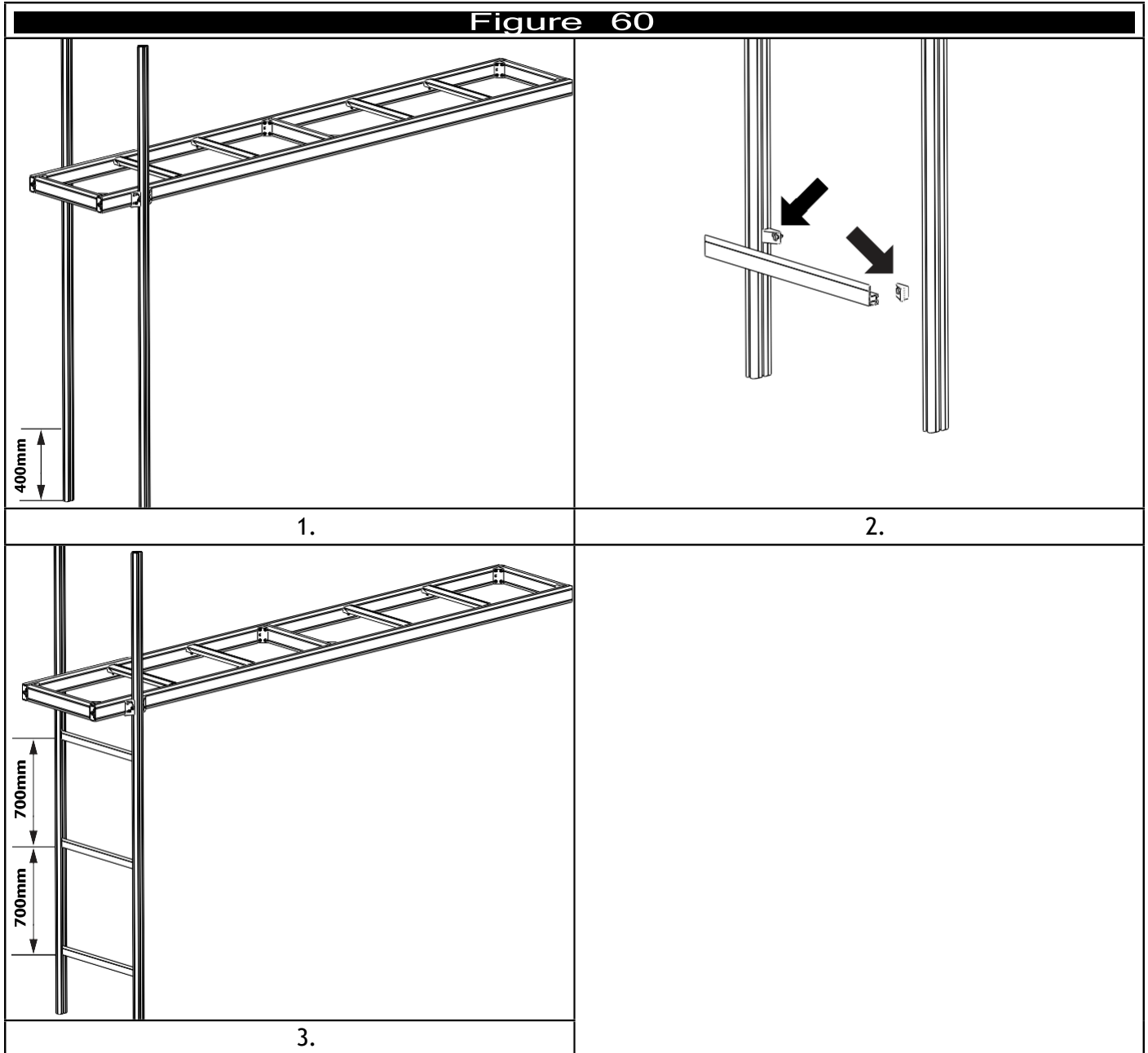

### 6.3 Diagonal Brace

1. Between two adjacent horizontal brace install the diagonal brace with 2x T-bolts.
2. Repeat for each adjacent horizontal brace.

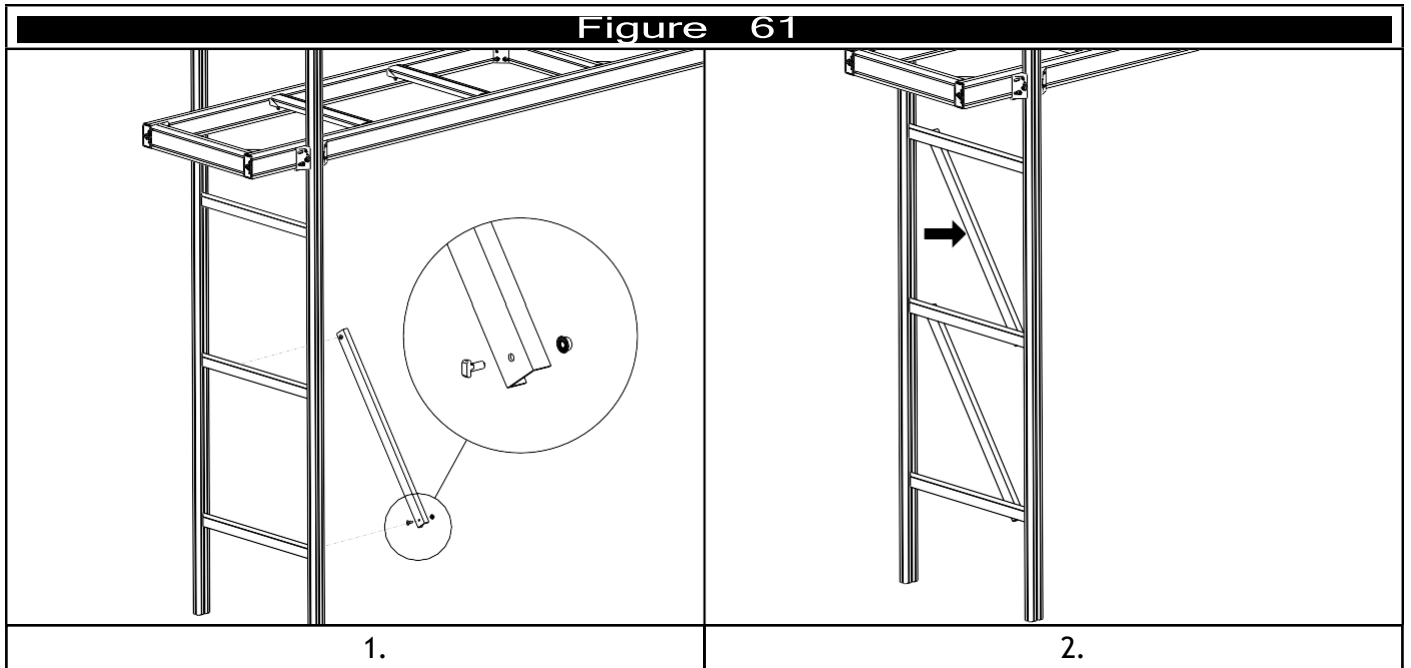

### 6.4 Platform Brace

1. Between the post and the platform extrusions install the brace with 2x T-bolts.
2. Repeat on the other side of the platform.

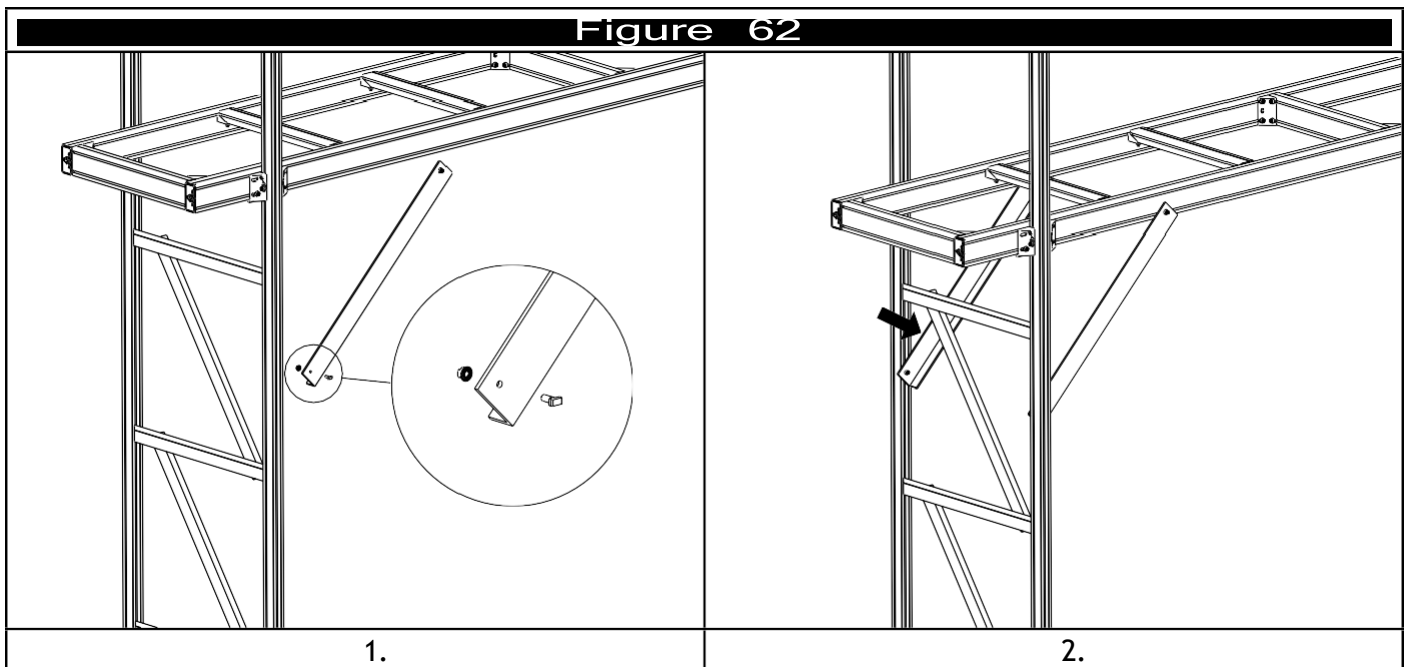

## 6.5 Concrete Footing

1. On each post install 2x Foot bracket (F) 1 on each side of the post. Bracket may be installed in either direction.

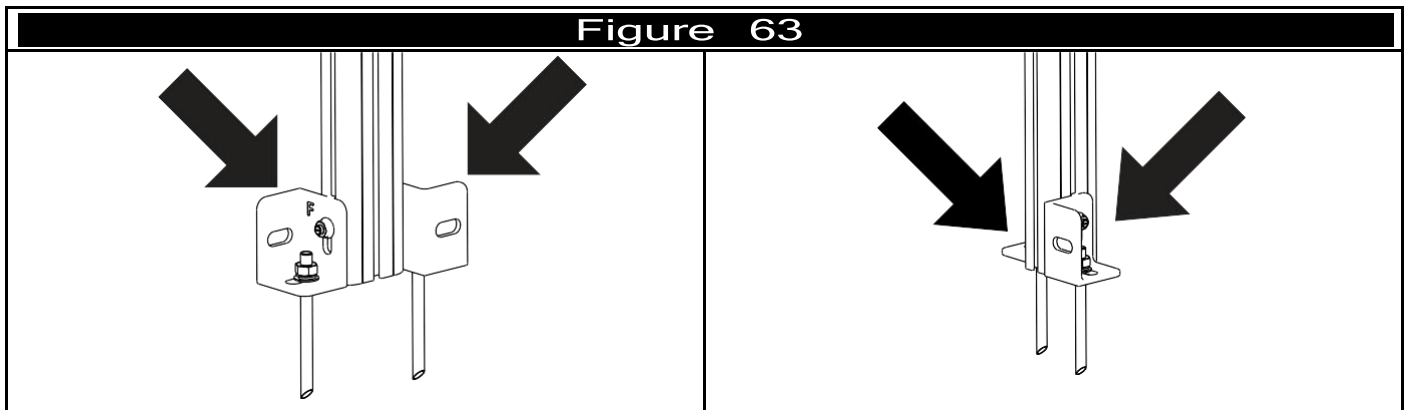

## 6.6 Sheetmetal Footing

1. Rivet the large channel to the roof with a waterproof seal below each of the 8x rivets as per section 3.3.4.
2. Place the two posts of the system into the channel and fix with 4x 35mm tek screws.
3. Install the bracing channel each with 2x 20mm tek screws into the large channel and 2x 35mm tek screws into the post.

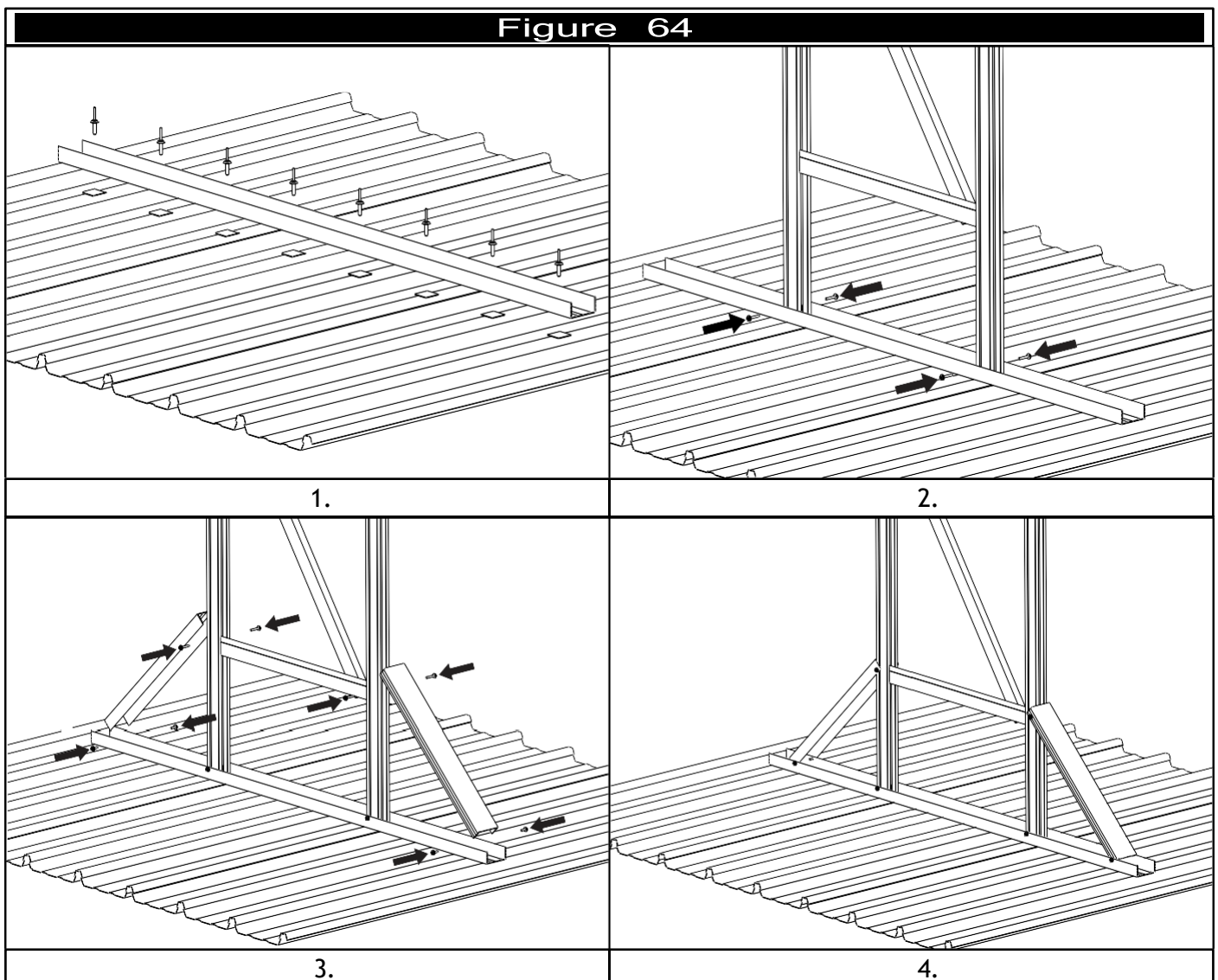

## 6.7 Sheetmetal Footing Large Platform

1. For platforms over 686mm in width the sheet metal footing kit can be cut in two to make 2 individual feet.
2. Each foot can then be used under each support post.
3. The brace section can be cut to prevent interferences with the horizontal brace member of the support structure.

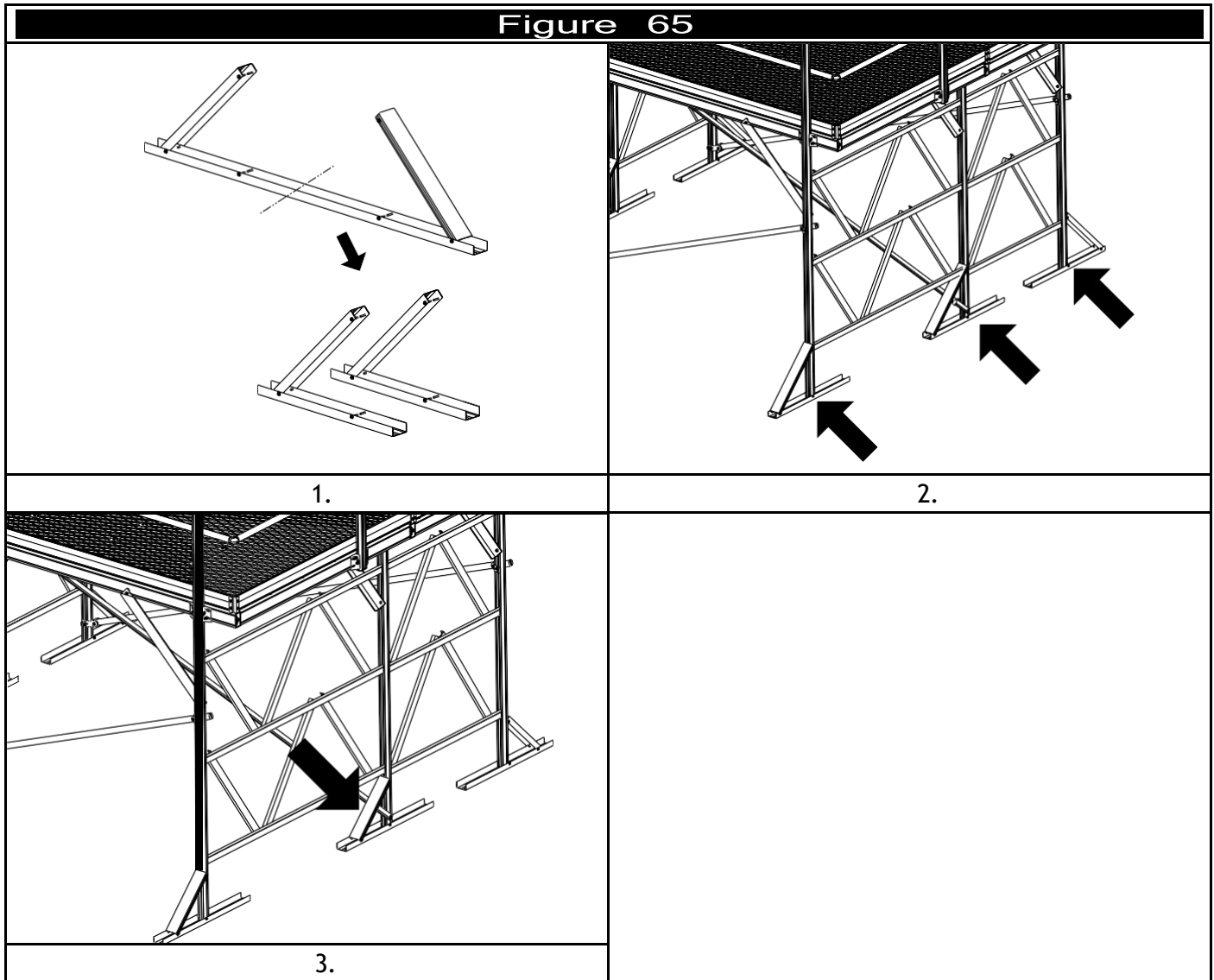

## 6.8 Cross Bracing

1. Install a cross brace bracket (GH) as close to foot as possible and another as close to the knee brace as possible on the adjacent post. See Section 4.7.
2. Connect the 2 brackets with a section of knee rail.

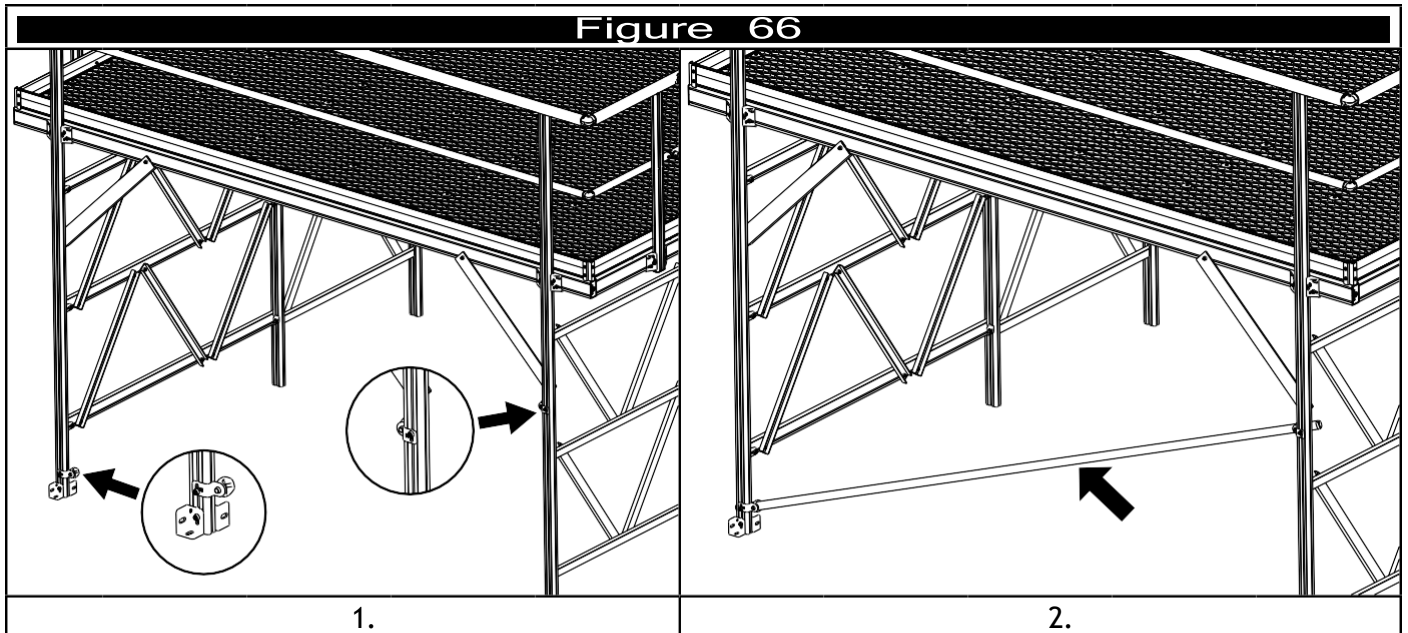

**BRACE CUT LENGTH (mm)**

|                      |      | SUPPORT STRUCTURE DISTANCE (mm) |      |      |      |      |      |      |      |
|----------------------|------|---------------------------------|------|------|------|------|------|------|------|
|                      |      | 3400                            | 3200 | 3000 | 2800 | 2600 | 2400 | 2200 | 2000 |
| PLATFORM HEIGHT (mm) | 2200 | 3766                            | 3584 | 3404 | 3226 | 3052 | 2880 | 2713 | 2550 |
|                      | 2000 | 3690                            | 3504 | 3320 | 3137 | 2957 | 2779 | 2605 | 2435 |
|                      | 1800 | 3624                            | 3434 | 3245 | 3058 | 2873 | 2690 | 2510 | 2333 |
|                      | 1600 | 3567                            | 3374 | 3182 | 2991 | 2801 | 2613 | 2427 | 2243 |
|                      | 1400 | 3521                            | 3326 | 3131 | 2936 | 2743 | 2550 | 2359 | 2169 |
|                      | 1200 | 3487                            | 3289 | 3091 | 2894 | 2698 | 2502 | 2306 | 2112 |
|                      | 1000 | 3463                            | 3264 | 3065 | 2866 | 2667 | 2469 | 2270 | 2072 |

## 6.9 Wall Mounted Supports (Concrete)

1. Fix the brackets to the wall with suitable fasteners through the 2 holes provided.
2. Place the platform on top of the brackets and fix the platform to each bracket with 2x I brackets.

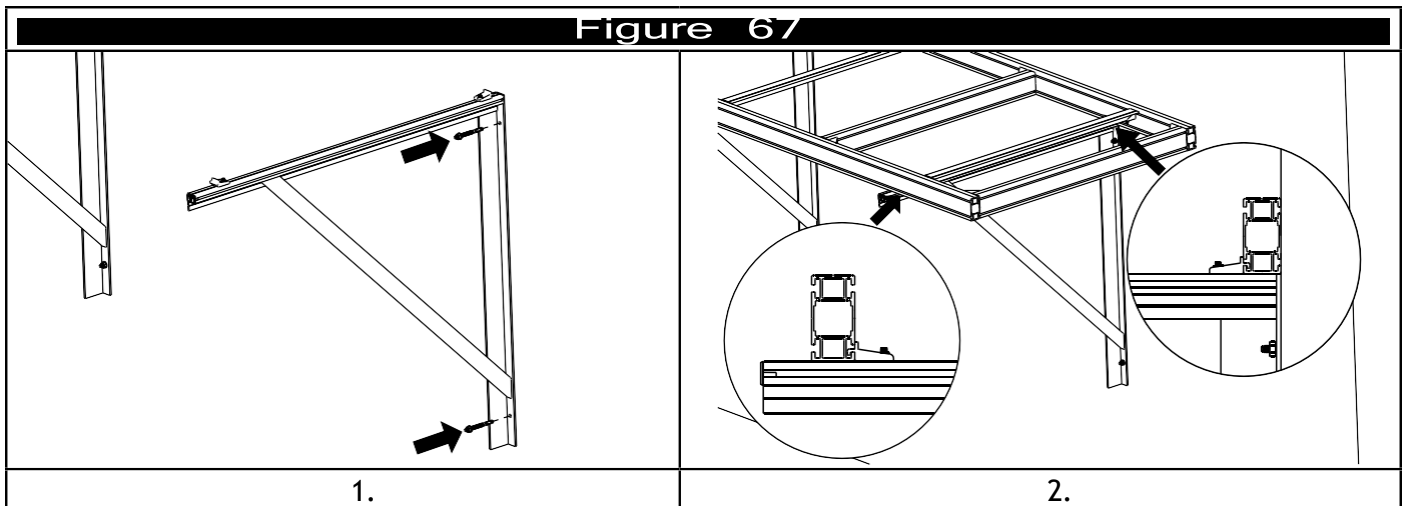

## 6.10 Wall Mounted Supports (Sheetmetal)

1. The brackets must span at least 2 purlins. If the spacing of the purlins is more than 1000mm, then the kit LADER002.PLT.MID.M.05 may be used to bridge the gap between purlins. The cantilever brackets must be installed within 400mm above the top purlin bracket, or 550mm below the top purlin bracket.
2. Fix to the brackets to purlins with toggle bolts. To install the toggle bolt, drill a 30mm hole through the sheetmetal and purlin. Assemble the toggle bolts as per Figure 68, and tighten the bolts to 15Nm.
3. Place the platform on top of the brackets and fix the platform to each bracket with 2x I brackets.

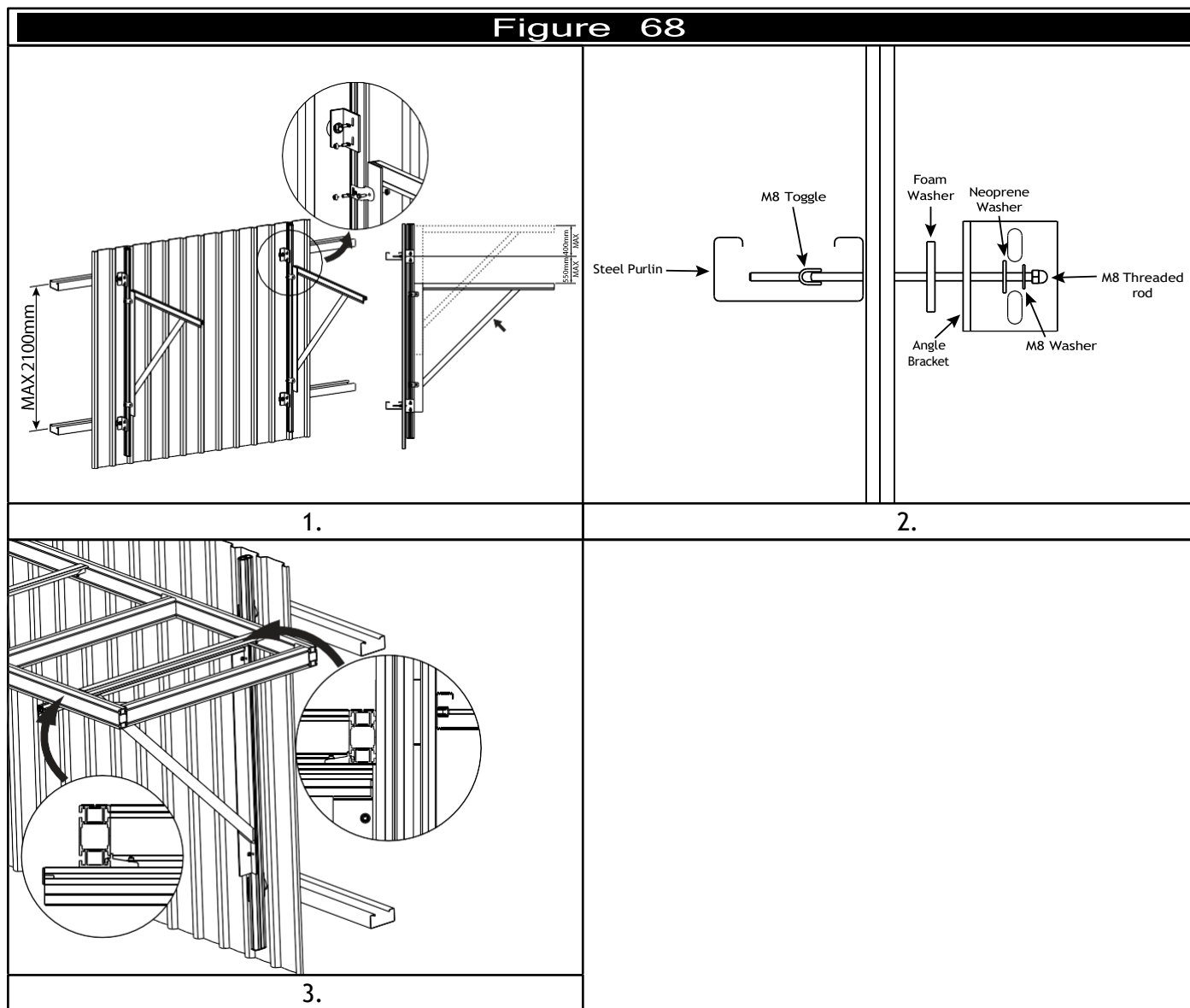

## 7 Staircases

### 7.1 Staircase Assembly

- ☑ In the below steps do not tighten the bolts beyond finger tight to allow adjustment.
- ☑ Each tread shall be orientated with the grip tape at the front.

1. Select a tread and fix the 4x Stringers to it with 4x M8 hex screws through the top hole.
2. Select a second tread and install it in to the bottom holes as above.
3. Select a third tread and install it in to the second most bottom holes as above.
4. Install the stringer end caps.

- ☑ All the remaining treads can be installed now however this will make the staircase heavier and harder to handle. Adding the remaining treads can be done later.

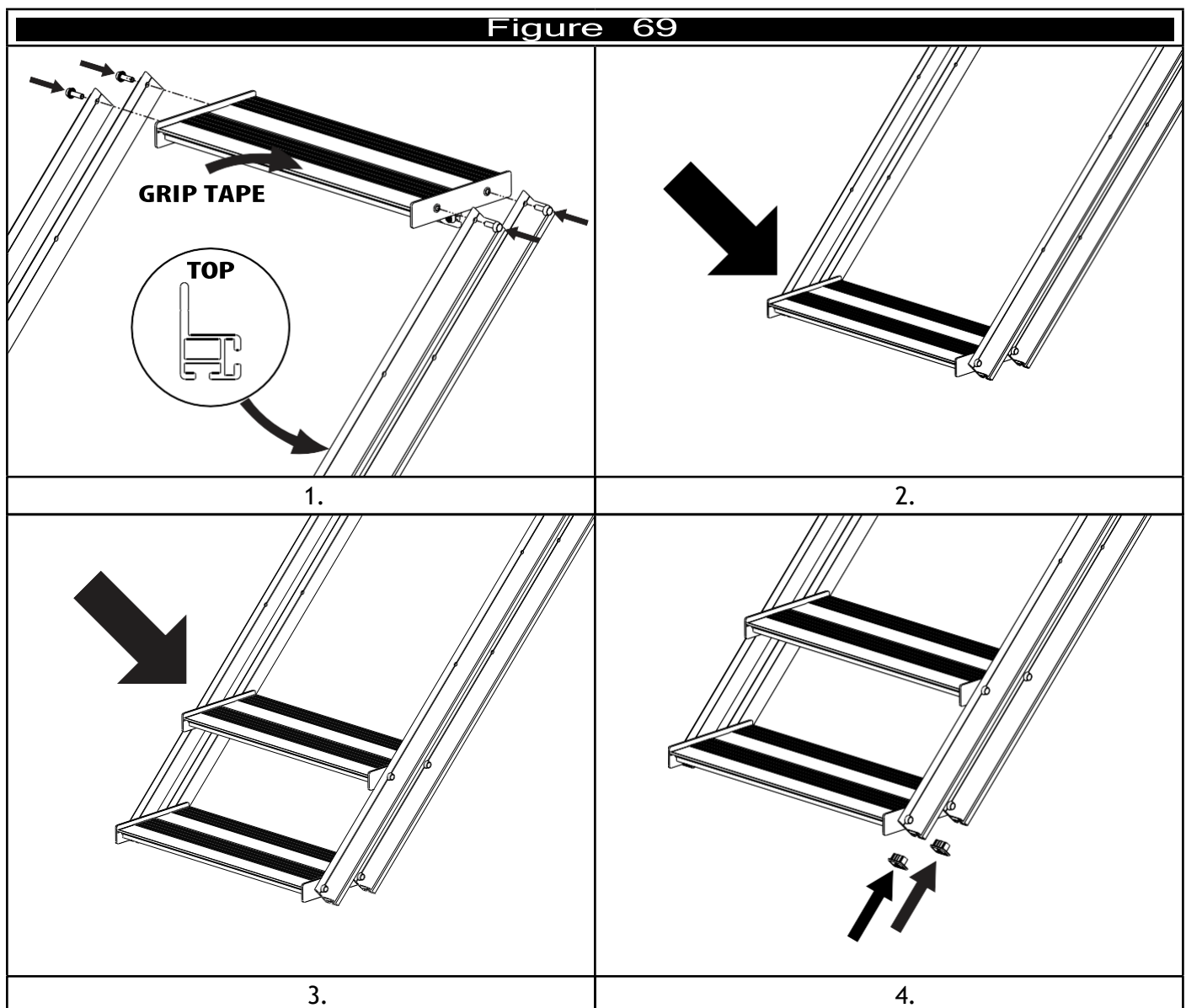

## 7.2 Top Tread

1. Install 2x Stair Bracket (A) at the below distance for the applicable tread size.

- I Tread 600mm wide; 400-500mm
- II Tread 900mm wide; 600-800mm
- III Tread 1200mm wide; 900-1100mm

2. Place the top stair tread into the brackets and fix in place as per Section 4.1.

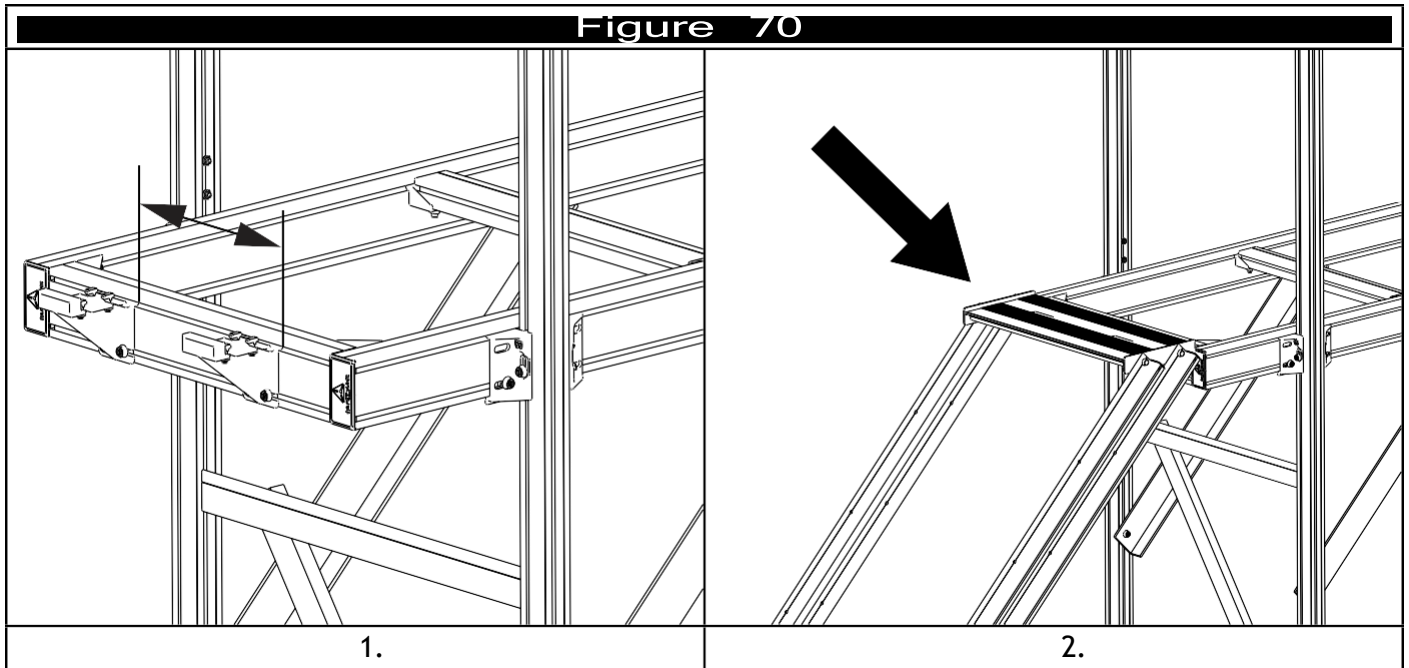

### 7.3 Bottom Tread

1. Measure the distance between the floor and the first tread and the first tread and second tread.
2. Using the adjustment tool (or standard packers) adjust the height of the stairs till these dimensions are equal.
3. Fix the bottom post to the stairs, within 300mm of the end of the stairs, with 2x stair post brackets (DH).
4. Install a second post on the other side of the stairs in the same way.
5. Attach the footing from either section 6.5 or 6.6.

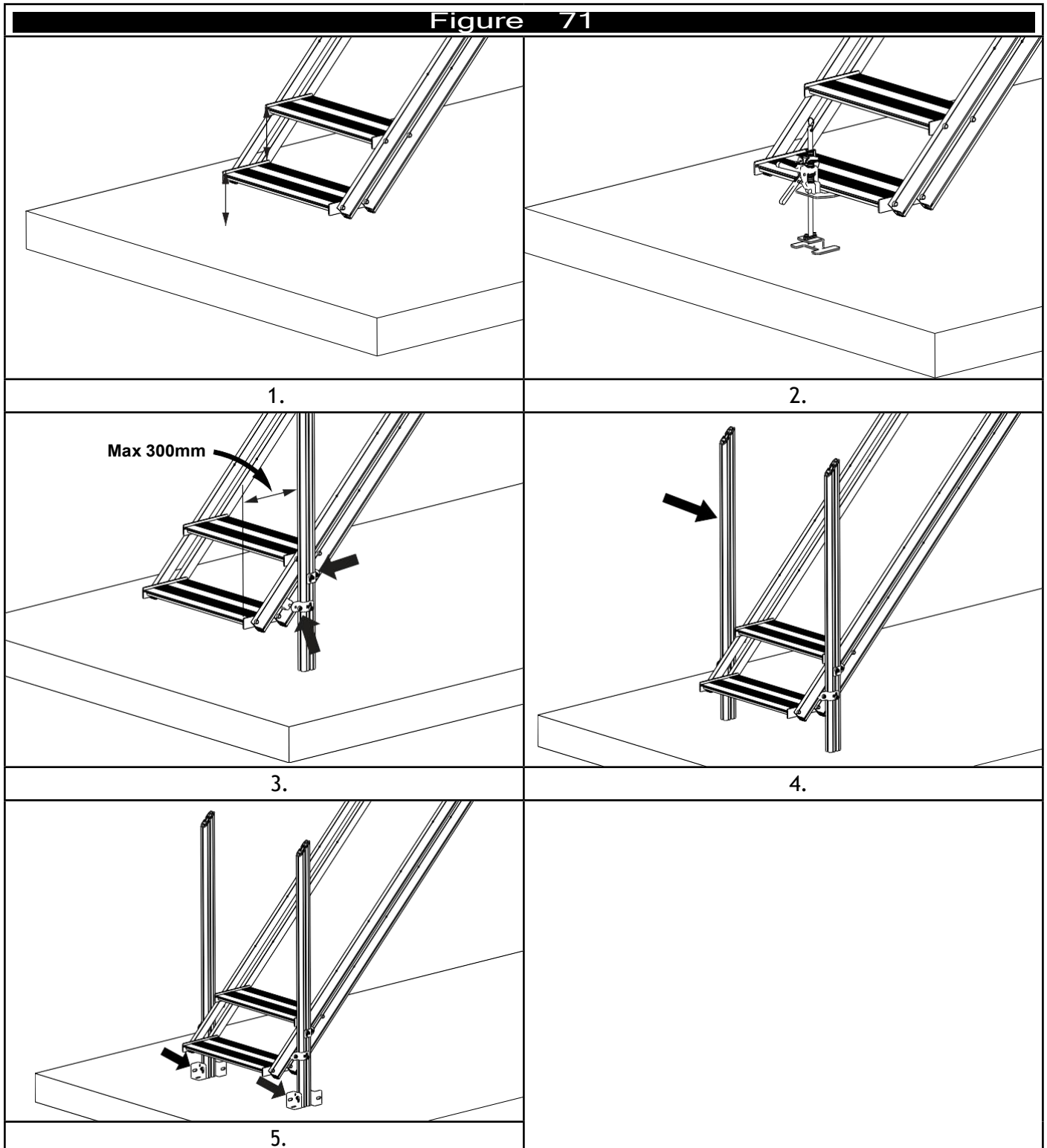

## 7.4 Tread Fixing

1. Fix each of the treads with 4x M8 screws and tighten.

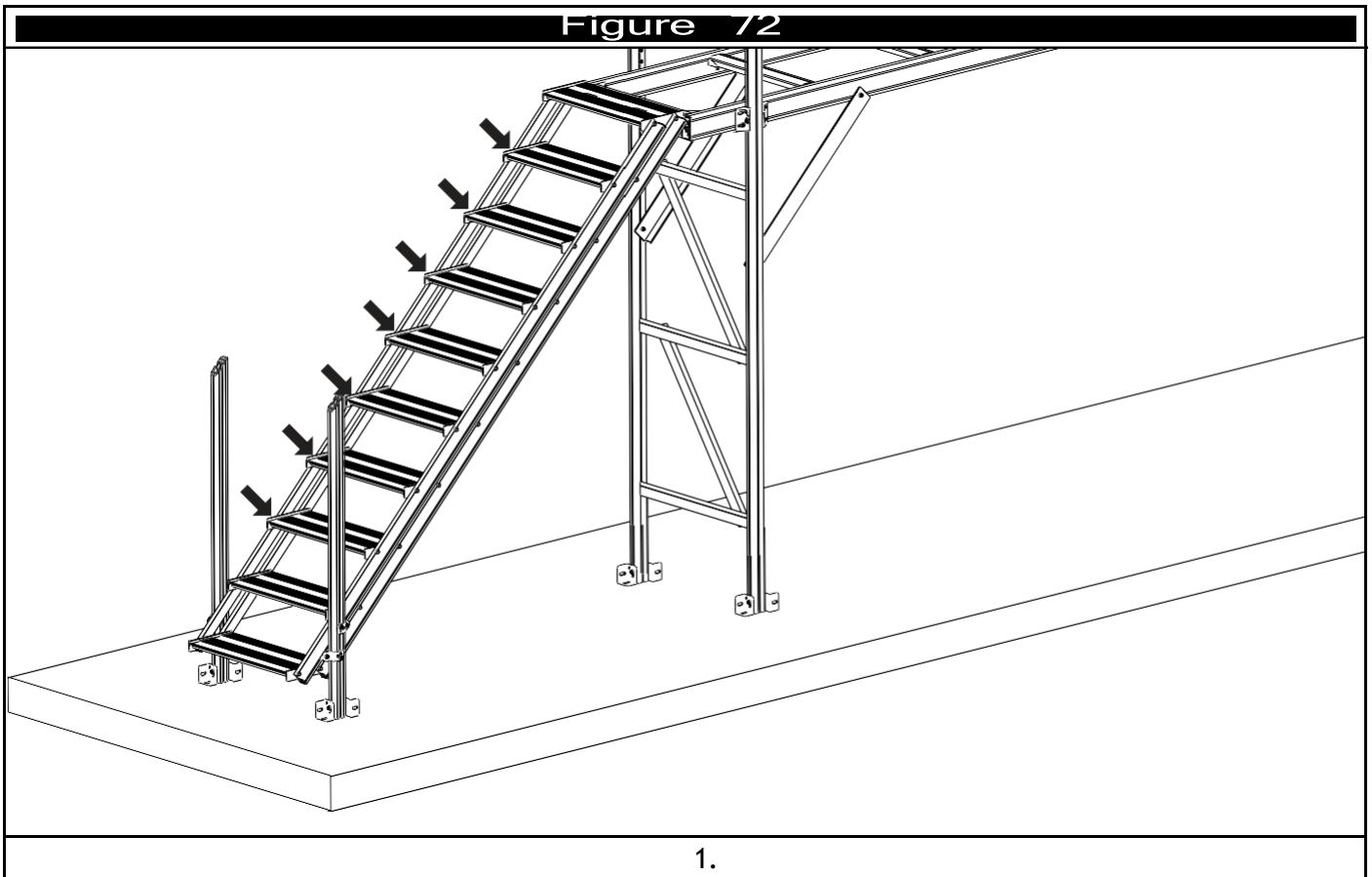

## 7.5 Staircase Single Post

1. Install the post with 2x Stair post bracket (D&H) in to the T-slot in the top stringer. The post shall extend 900mm above the next tread and shall rest on both stringers. the post shall be between 300mm and 400mm from the start of the platform.
2. Install the cap in the bottom of the post.

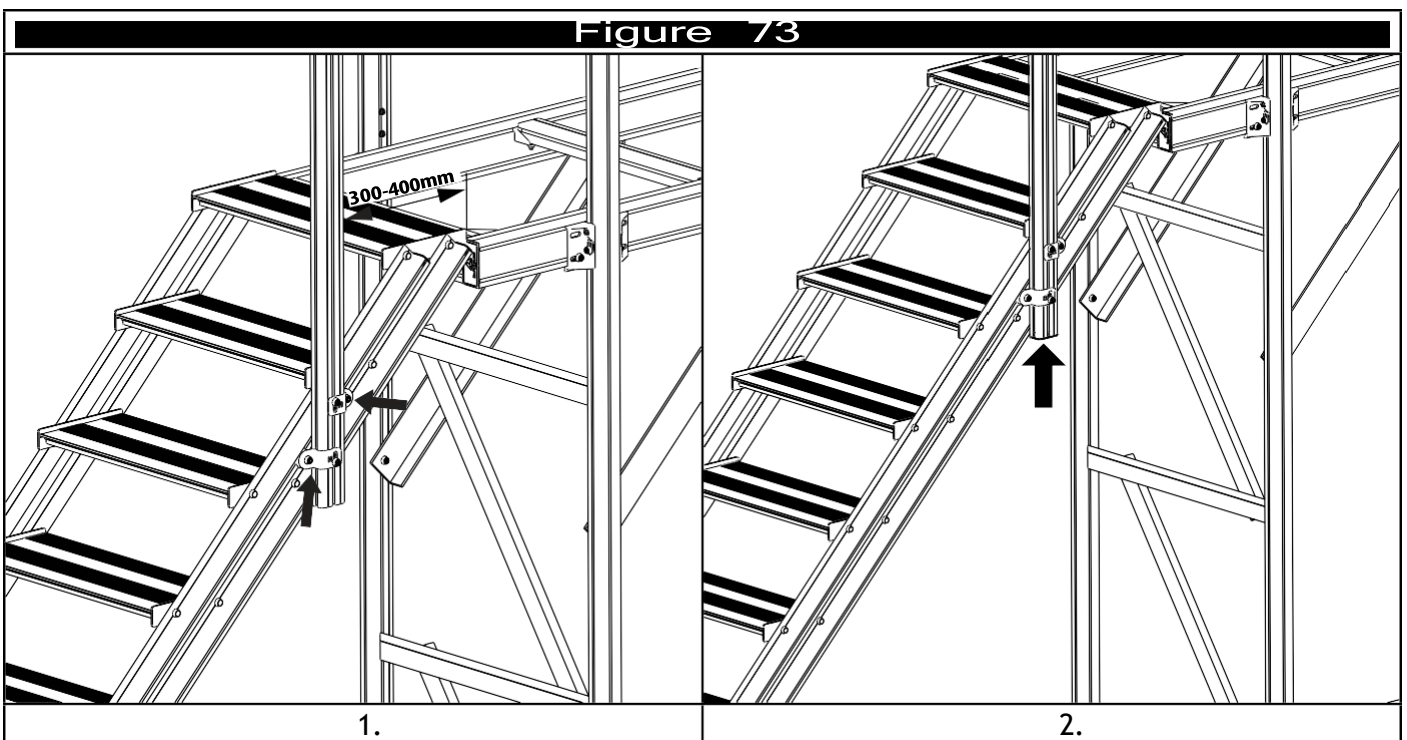

## 7.6 Staircase Mid Support

1. Fix the two support posts to the stairs with 2x stair post brackets (DH).

**⚠** *Ensure the 2 spans created either side of the post do not exceed 10 unsupported treads. See Section 3.1.7.*

2. Install the horizontal braces as per Section 6.2.

3. Install the diagonal braces as per Section 6.3.

4. Install the feet as per sections 6.5, 6.6 or 6.7.

Figure 74

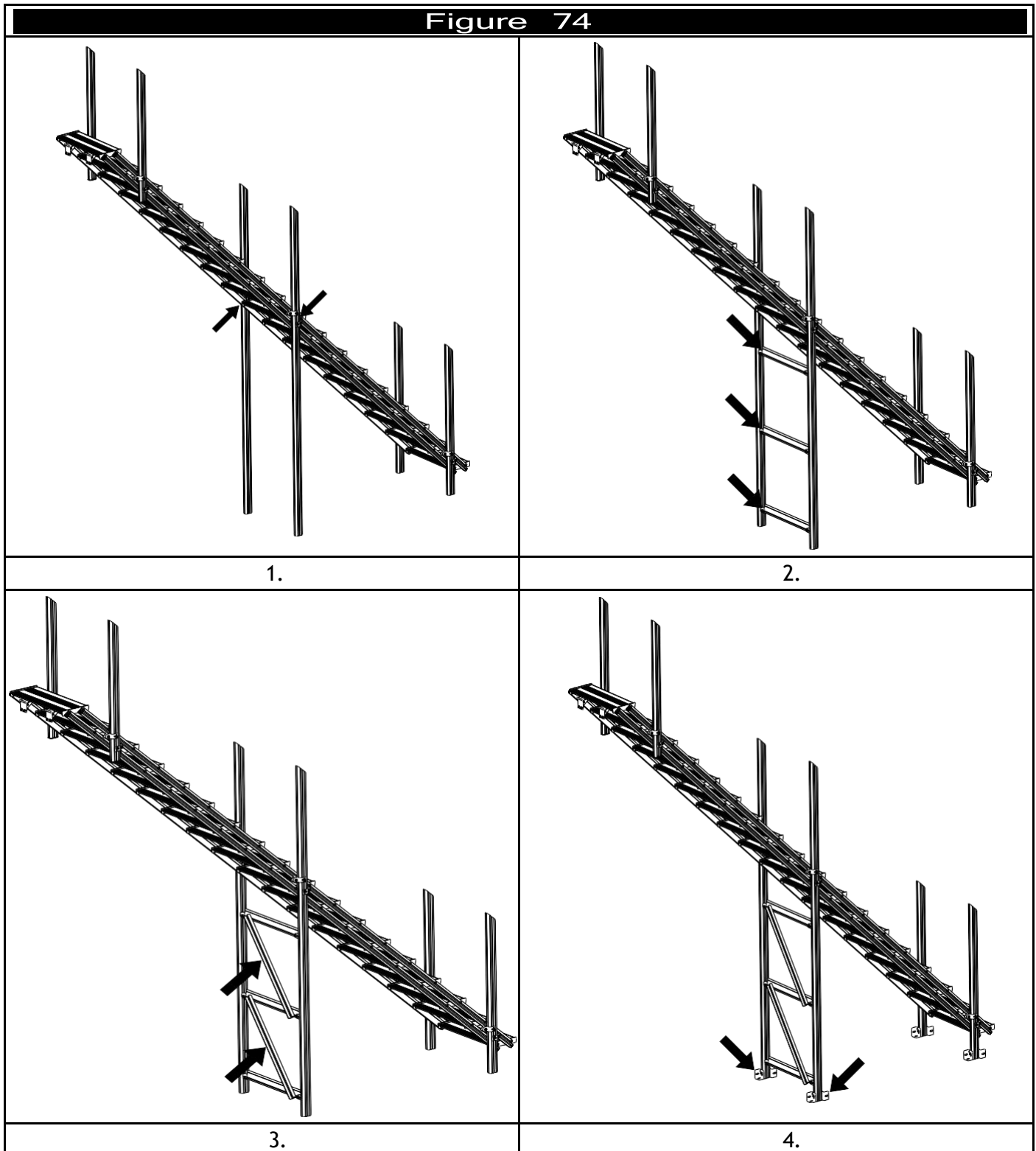

## 7.7 Staircase to Structure

1. Install 2x Stair Bracket (K) at the below distance for the applicable tread size. The brackets should be installed 25mm below the level of the landing.

- I Tread 600mm wide; 400-500mm
- II Tread 900mm wide; 600-800mm
- III Tread 1200mm wide; 900-1100mm

2. Place the top stair tread into the brackets and fix in place as per Section 4.10.

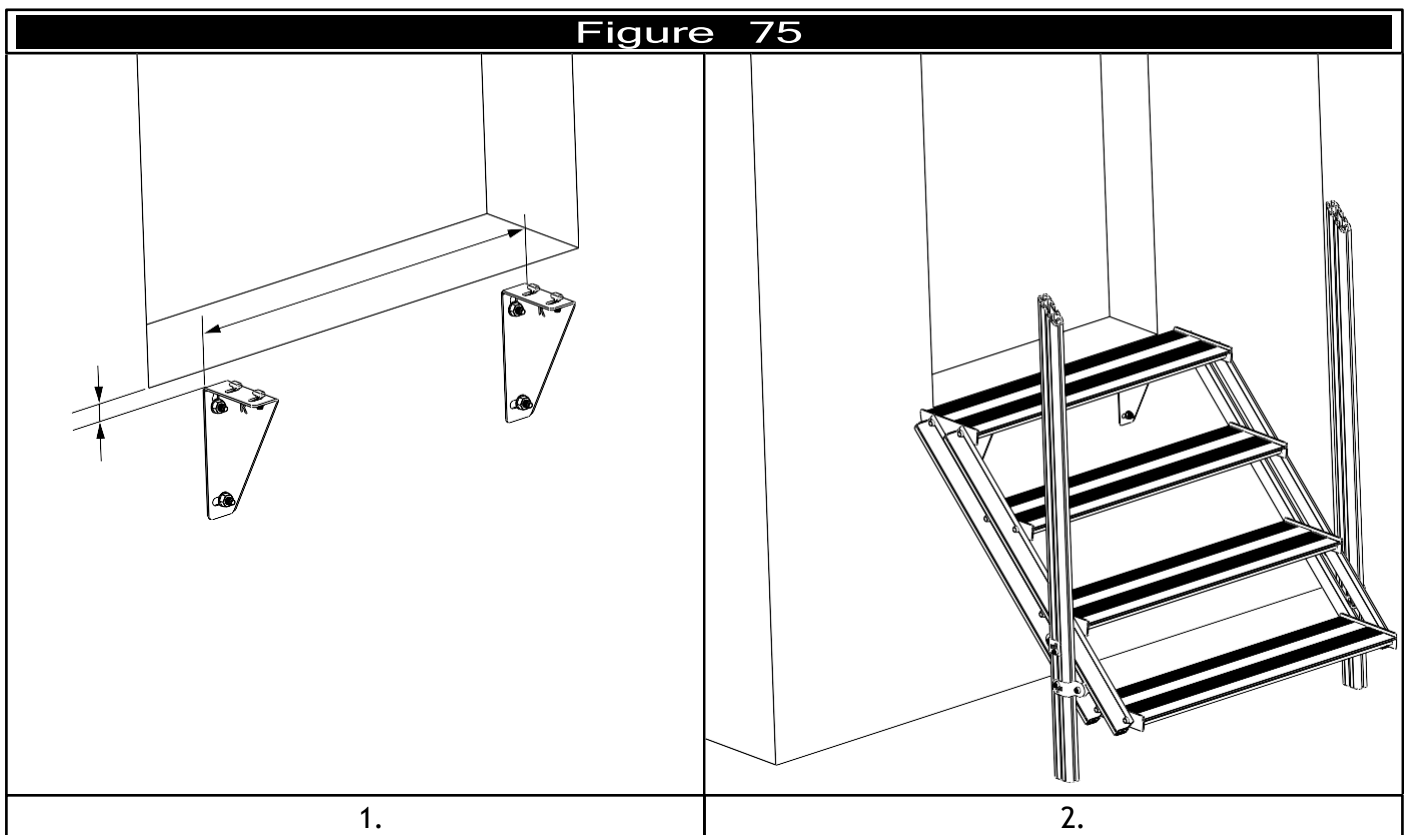

## 7.8 Ladder to Platform

1. Install 2x Stair Bracket (A) at between 400-500mm a part.
2. Place the ladder bracket into the Stair Brackets and fix in place.
3. Install the Ladder with 2xM8x60mm cup bolts.

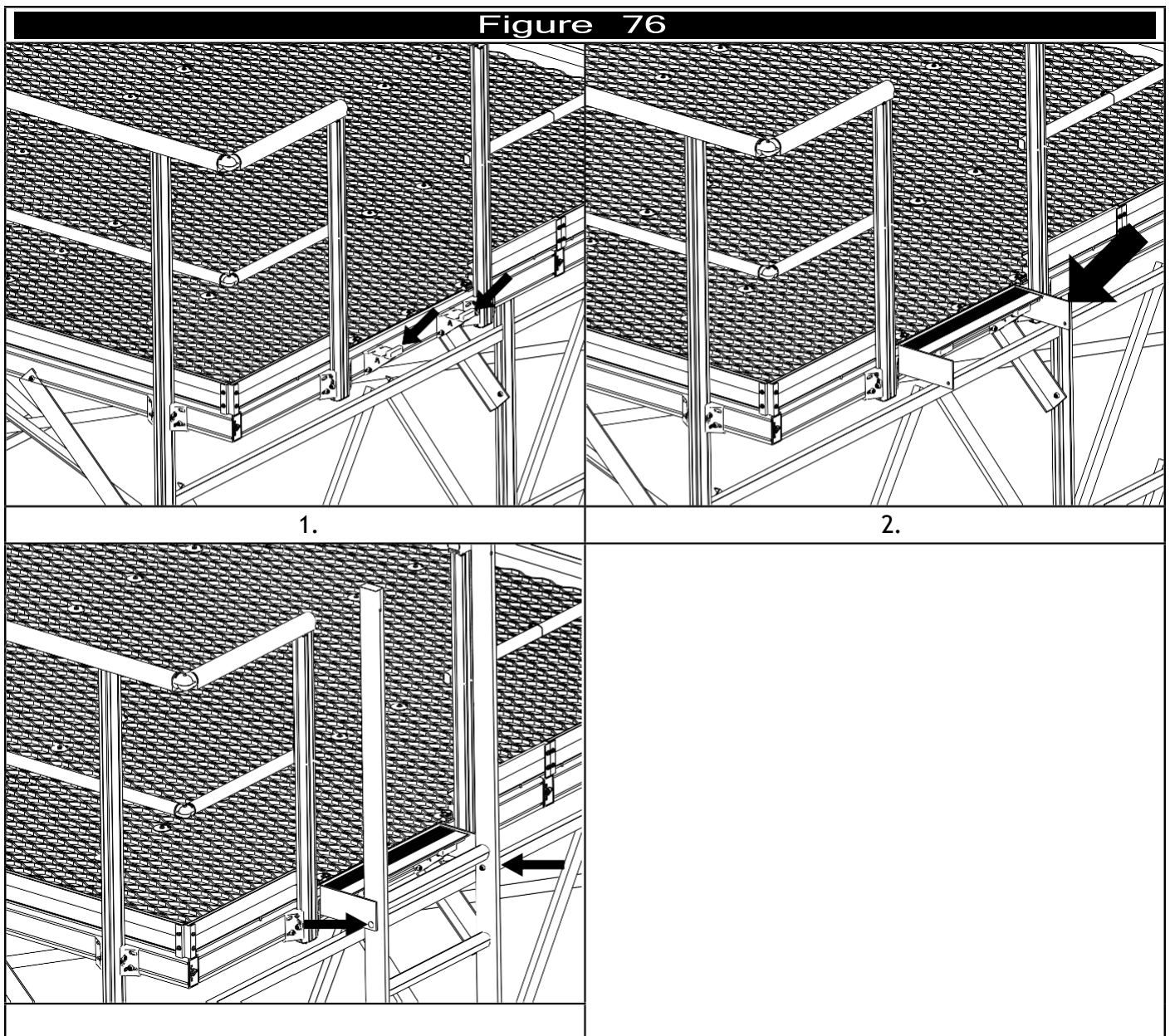

## 8 Guardrails and Toe boards

### 8.1 Guardrails

The handrail shall be fixed to each stanchion with 2x 20mm tek screws, one in each side of the post.

All middle rails shall be fixed with 2x 50mm tek screws in to each stanchion. The 2 tek screws shall be installed from the same side, through the centre of the middle rail.

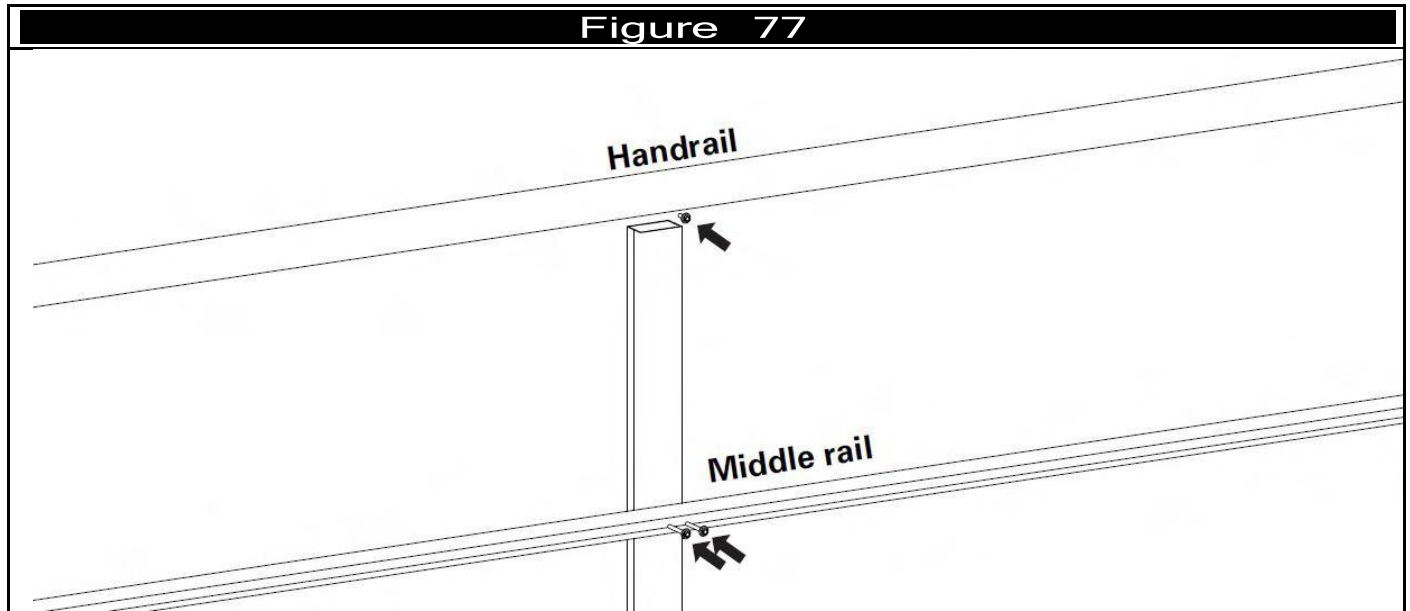

### 8.2 Guardrail Joins

When joining handrails and middle rails, insert the appropriate splice piece half way in to the profile and fix with 2x 20mm tek screws. Slide the next length of rail over the exposed part of splice and fix with 2x 20mm tek screws. Handrail screws shall be installed from underneath. Middle rail screws shall be installed in the side.

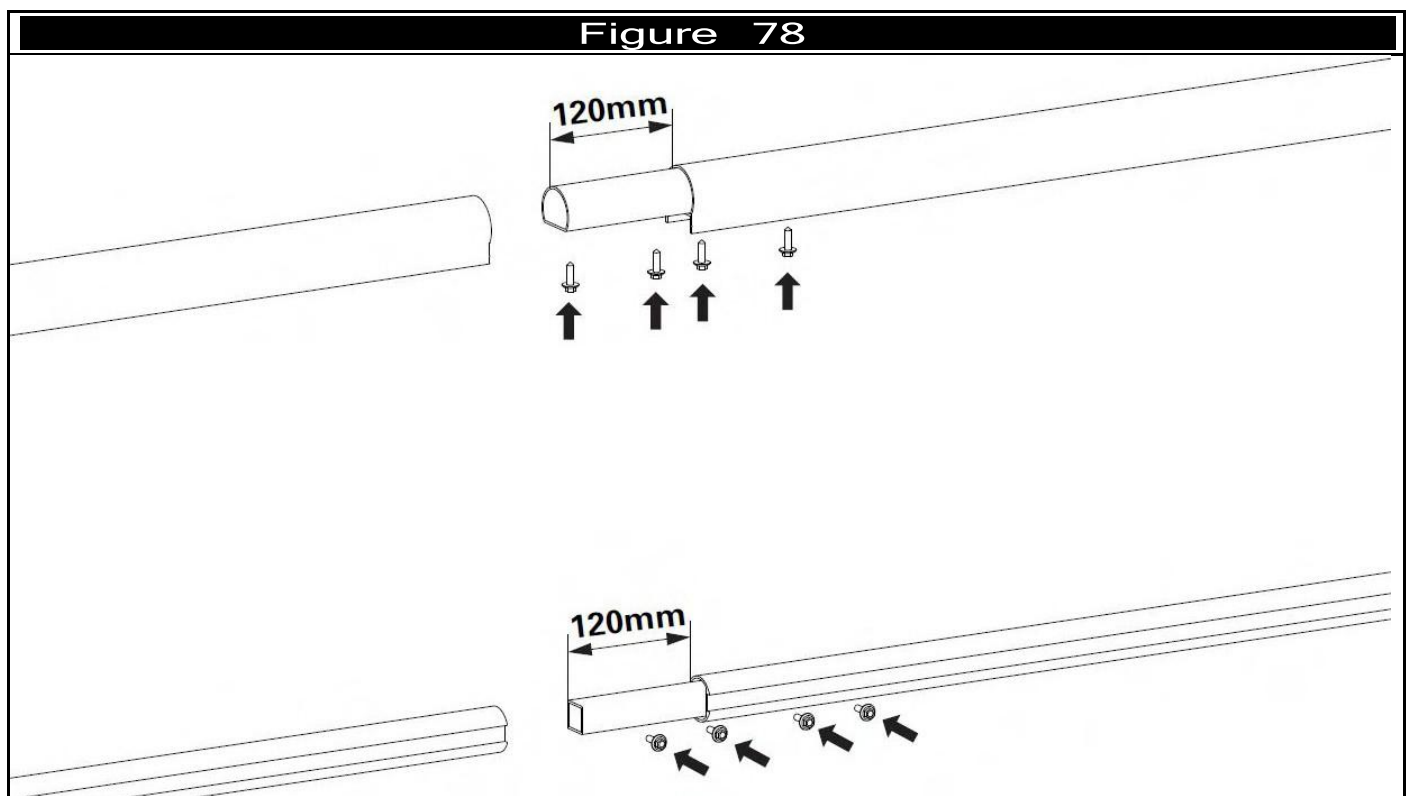

### 8.3 Rail Corners

Install the rail corners with a 20mm tek screw in each side. Handrail screws shall be installed from underneath. Middle rail screws shall be installed in the side.

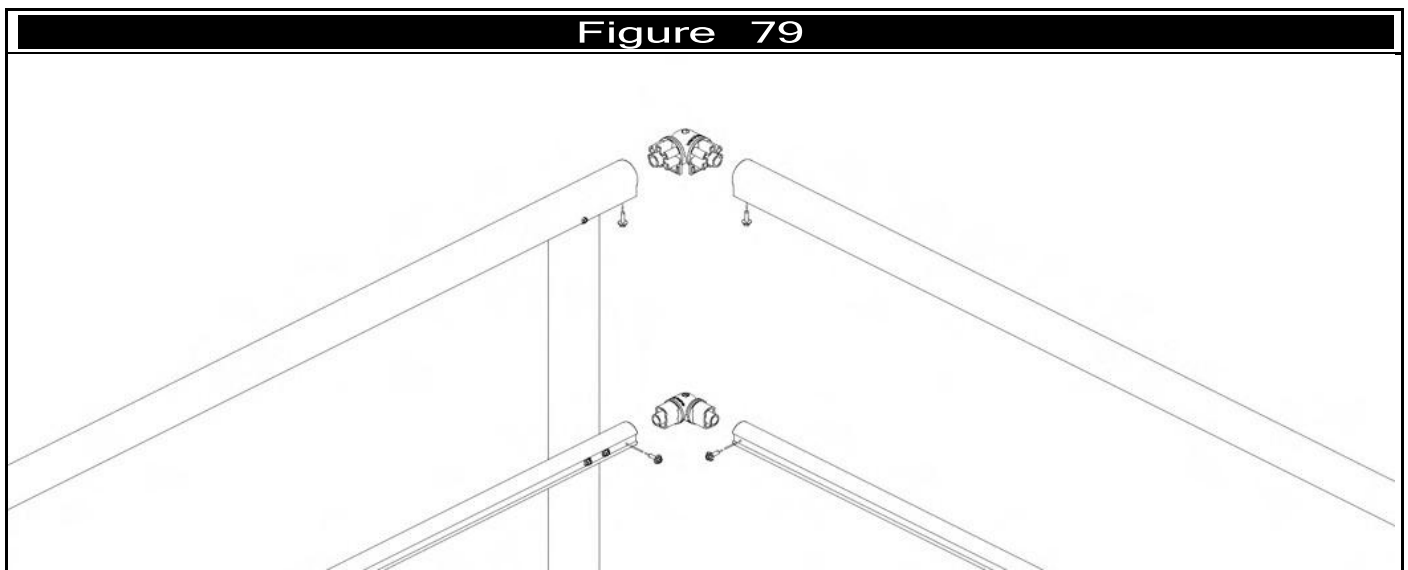

### 8.4 Rail Caps

Install end caps with a rubber mallet.

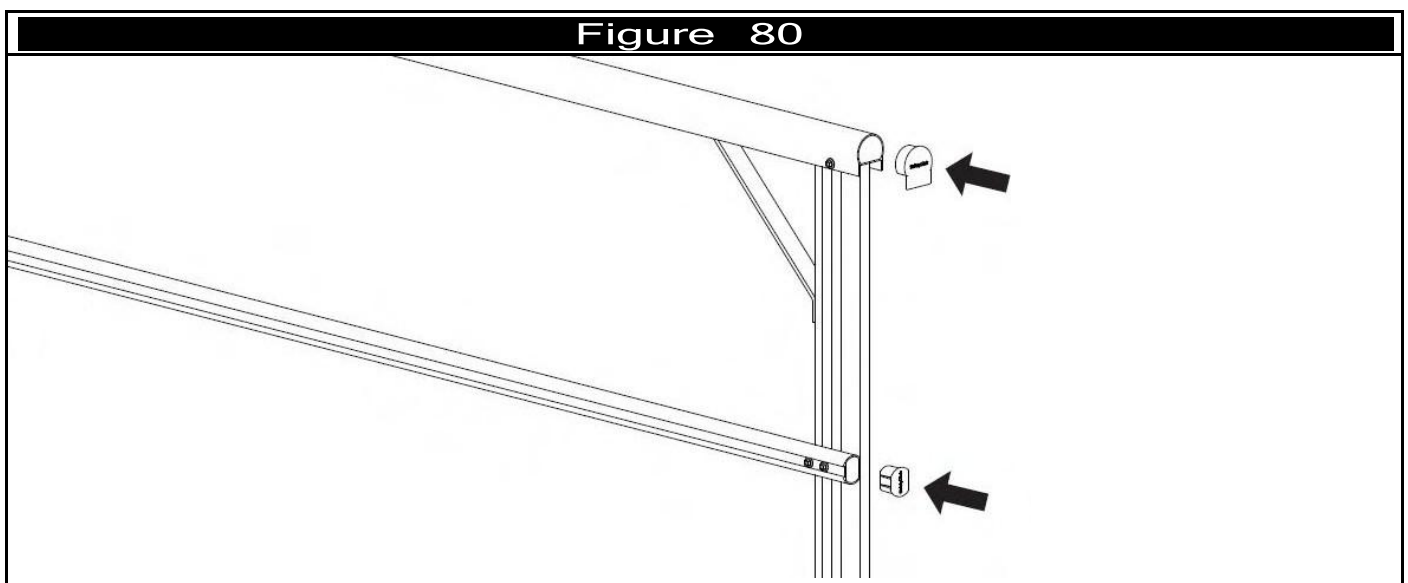

## 8.5 Toeboard

The toe board shall be fixed with 2x 20mm tek screws in to each stanchion.

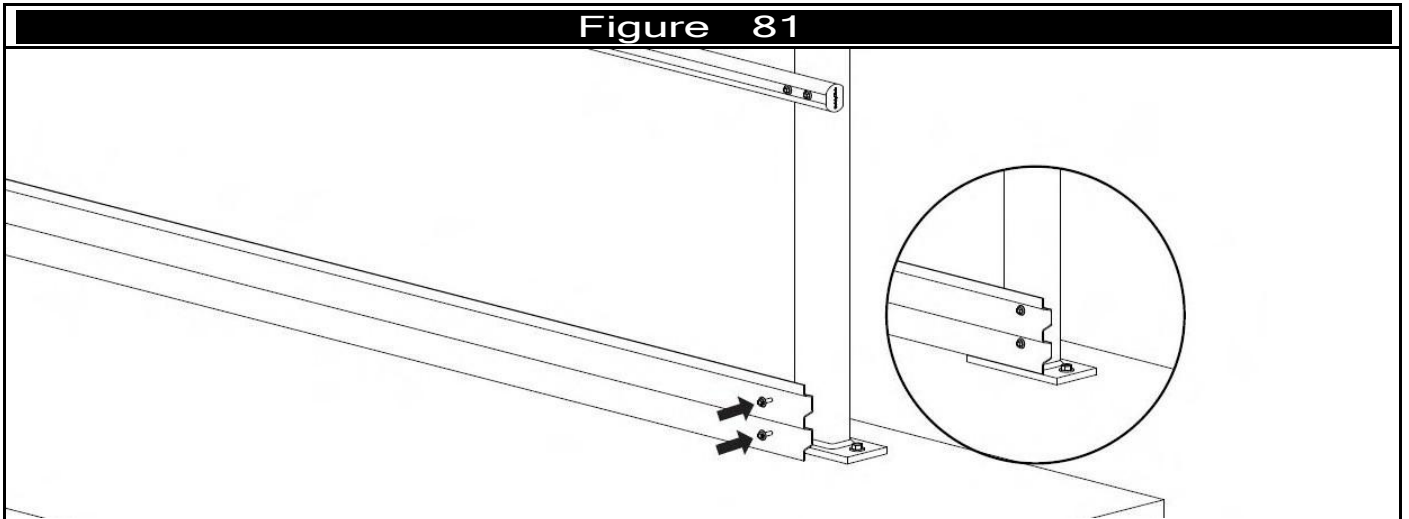

## 8.6 Toeboard Join

The toeboard shall be joined with a joiner and 4x 12g screws.

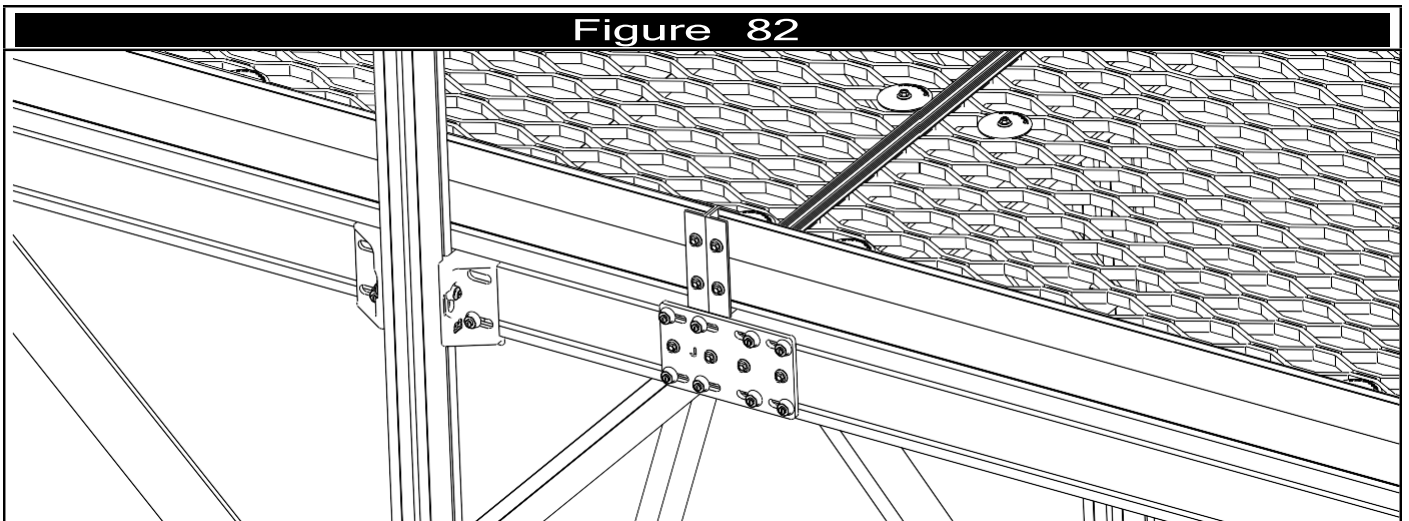

## 8.7 Toeboard Corner

Toeboard corners shall be joined with a corner piece and 4x 12g screws.

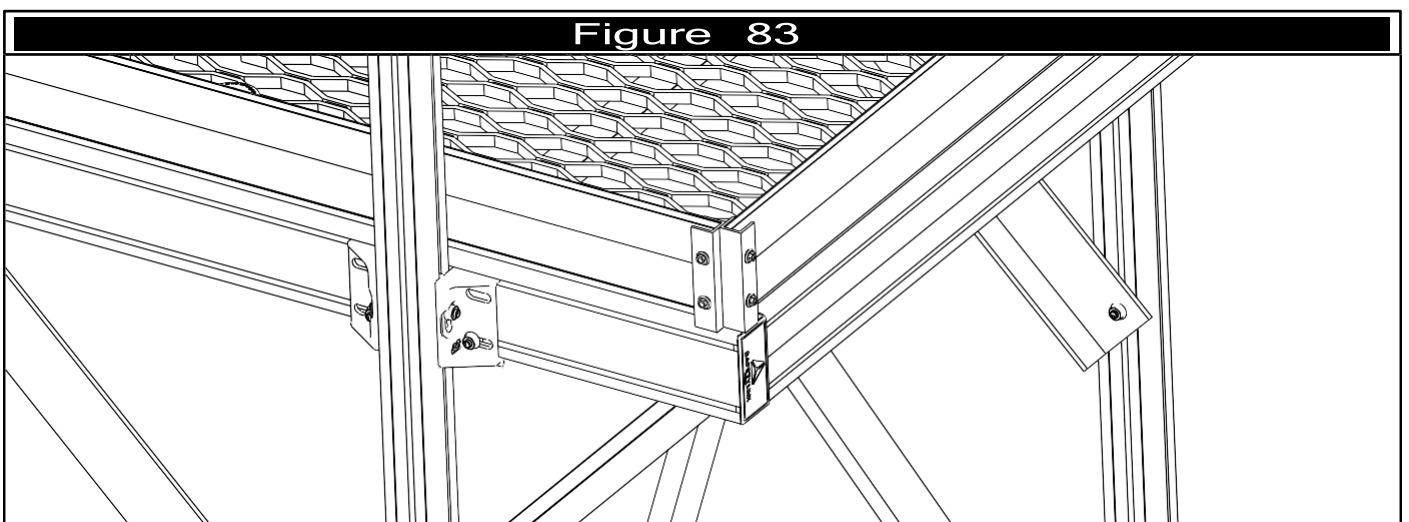

## 9 Tools

### 9.1 Middle Rail Spacer

The Middle Rail Spacer tool can be used to hang the middle rail from the handrail whilst it is being fixed to ensure the requirements of Section 3.2.5 are met.

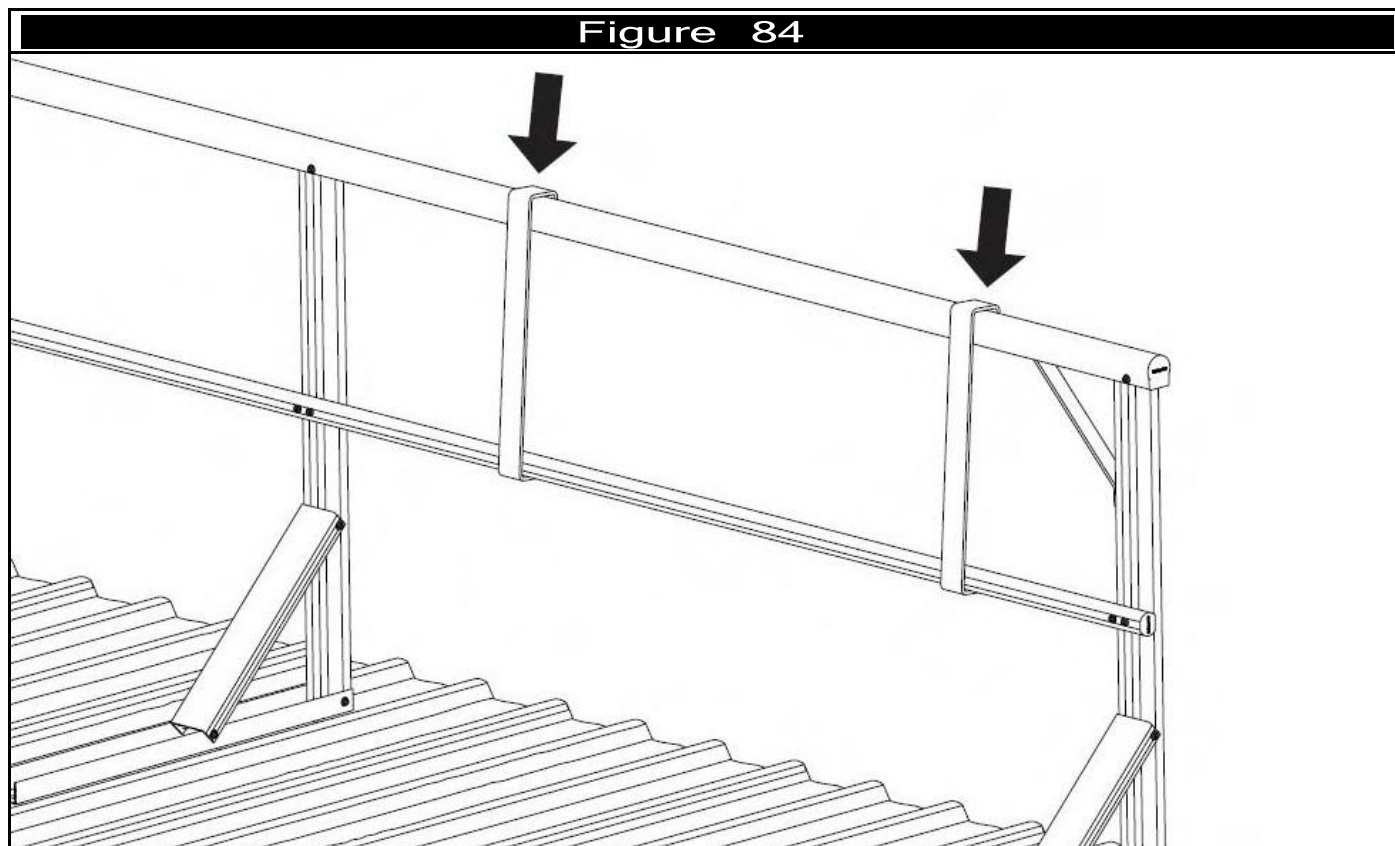

### 9.2 Stair and Platform Jack

The Stair and Platform Jack can be used to level the stair treads and platforms. The jack can be placed below the first tread to assist in raising or lowering the stairs or on a platform support to raise or lower the platform. All fasteners in the surrounding brackets shall be loosened prior to using the jack.

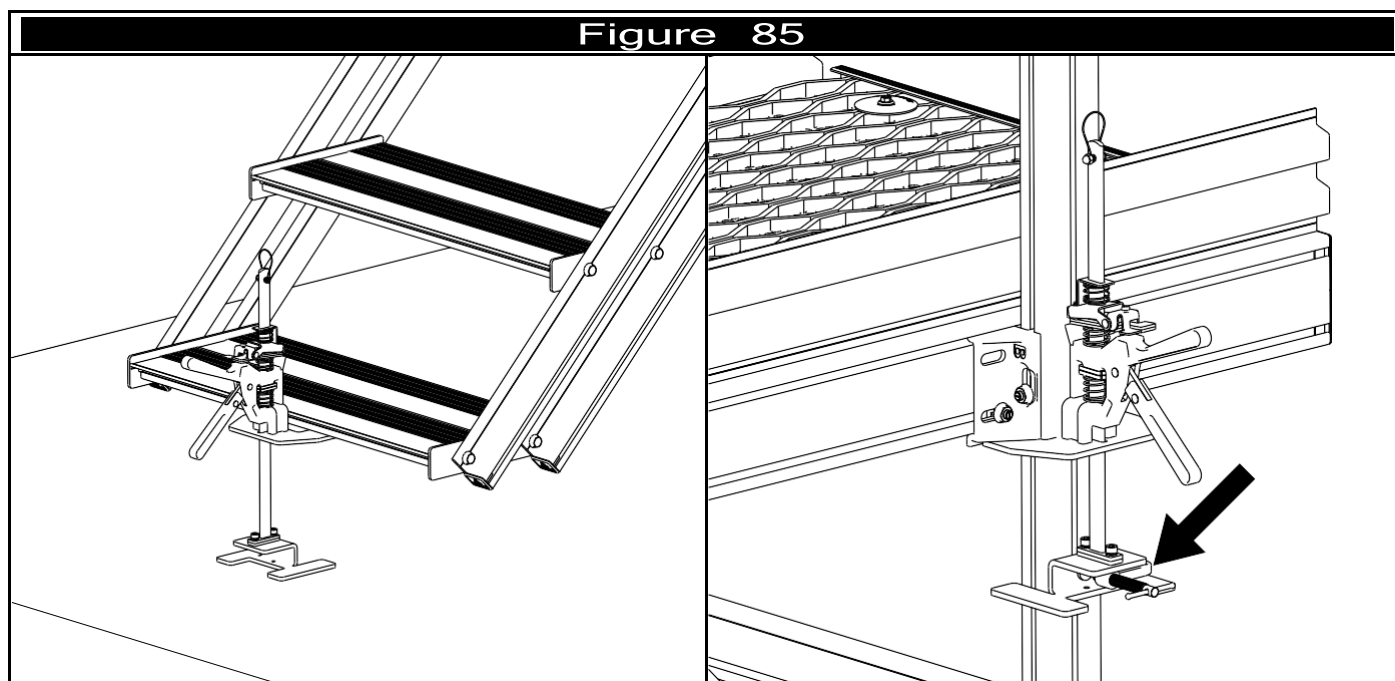

The jack has the following features;

1. Clamp to hold the base on a support post for lifting and lowering the platform.
2. Lever to lift the jack.
3. Button to lower the jack.
4. Button to lower the jack by a step.
5. Screw to increase or decrease the size of the lowering step.

Figure 86

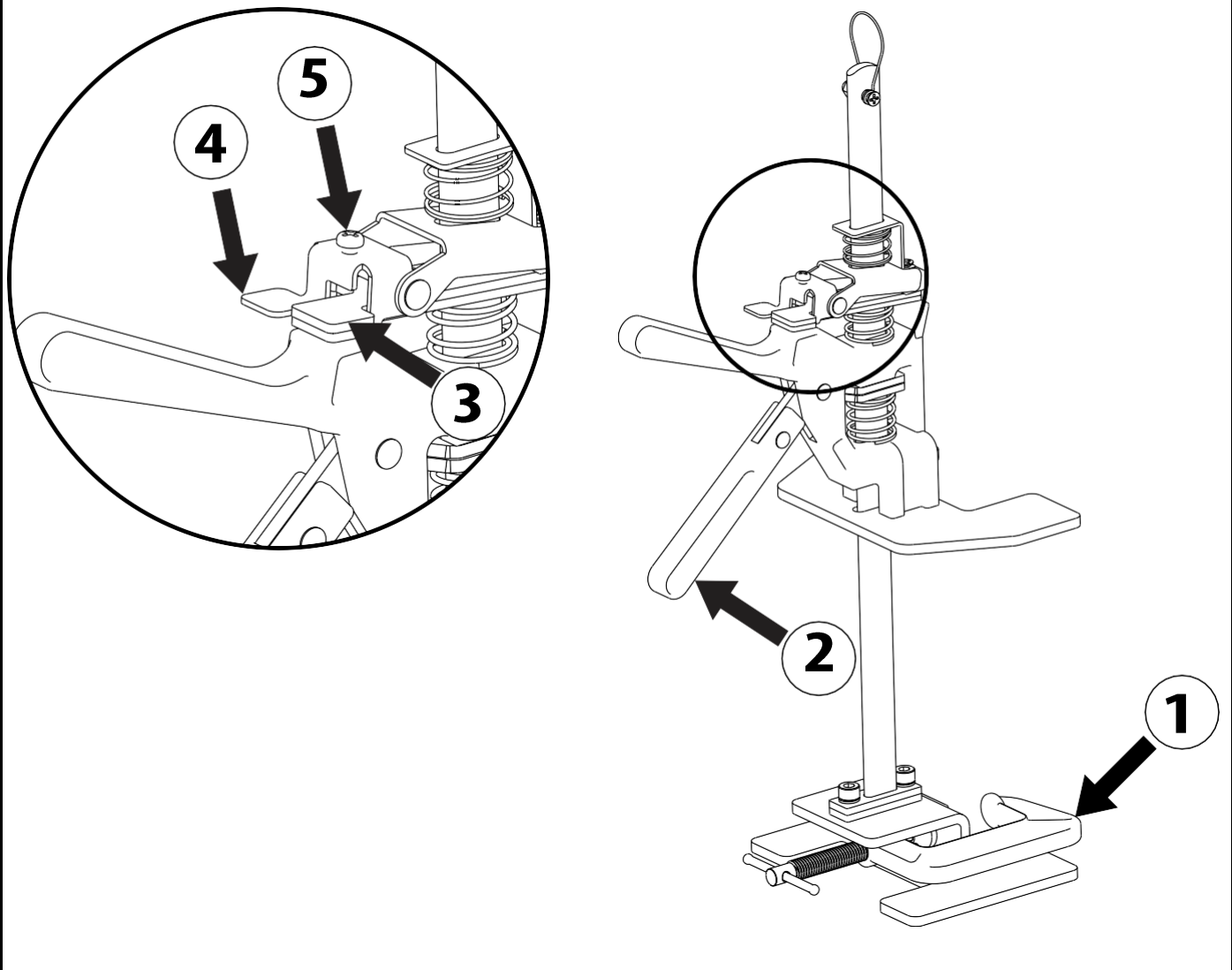

## 10 Inspection

### 10.1 Inspection Period

All FastFit access systems shall be inspected every 12 months by a competent height safety installer.

| <b>INSPECTION RECORD</b>      |   |                          |                          |
|-------------------------------|---|--------------------------|--------------------------|
| Product Code                  |   | Date of Manufacture      |                          |
| Serial or Batch No.           |   | Date of Install          |                          |
| Inspector                     |   | Date of Inspection       |                          |
| <b>SECTION</b>                | <b>INSPECTION</b>   | <b>USER</b>              | <b>COMPETENT PERSON</b>  |
| <b>SECTION 3.1 ON PAGE 32</b> | Check the dimensional requirement of the applicable sections have been met.   | <input type="checkbox"/> | <input type="checkbox"/> |
|                               | Comments:   |                          |                          |
| <b>SECTION 3.2 ON PAGE 43</b> | AS1657 requirements. Check the requirements of the applicable sections have been met.   | <input type="checkbox"/> | <input type="checkbox"/> |
|                               | Comments:   |                          |                          |
| <b>SECTION 3.3 ON PAGE 47</b> | Check the fasteners have been installed correctly and meet the requirements of the applicable section.  | <input type="checkbox"/> | <input type="checkbox"/> |
|                               | Comments:   |                          |                          |
| <b>SECTION 4 ON PAGE 50</b>   | Inspect the brackets have been installed with the correct number and type of fastener. Inspection for cracks, damage, corrosion or signs of over loading.                   | <input type="checkbox"/> | <input type="checkbox"/> |
|                               | Comments:   |                          |                          |
| <b>SECTION 5 ON PAGE 59</b>   | Inspect the platform has been assembled correctly and contains the correct number and type of fasteners. Inspection for cracks, damage, corrosion or signs of over loading. | <input type="checkbox"/> | <input type="checkbox"/> |
|                               | Comments:   |                          |                          |

|                             |  |                          |                          |
|-----------------------------|--|--------------------------|--------------------------|
| <b>SECTION 6 ON PAGE 65</b> | Inspect the platform supports are installed correct at appropriate spacing. Inspect for the correct number and type of fasteners. Inspection for cracks, damage, corrosion or signs of over loading. | <input type="checkbox"/> | <input type="checkbox"/> |
|                             | Comments:  |                          |                          |
| <b>SECTION 7 ON PAGE 72</b> | Inspect the stairs are level and spaced correctly. Inspect for the correct number and type of fasteners. Inspection for cracks, damage, corrosion or signs of over loading.                          | <input type="checkbox"/> | <input type="checkbox"/> |
|                             | Comments:  |                          |                          |
| <b>SECTION 8 ON PAGE 79</b> | Inspect the guardrails have been assembled correctly and contains the correct number and type of fasteners. Inspection for cracks, damage, corrosion or signs of over loading.                       | <input type="checkbox"/> | <input type="checkbox"/> |
|                             | Comments:  |                          |                          |

# Warranties

## EXTRACT: SAFETYLINK PTY LTD STANDARD TERMS AND CONDITIONS

- 1.1 To the extent permitted by law all implied conditions, warranties and undertakings are expressly excluded.
- 1.2 Except as provided in this clause the Company shall not be liable for any loss or damage, whether direct or indirect (including consequential losses or damage) arising out of any breach of contract by the Company or any negligence of the Company, its employees or agents.
- 1.3 Should the Company be liable for a breach of a guarantee, condition or warranty implied by the Australian Consumer Law (not being a guarantee, condition or warranty implied by sections 51, 52 and 53 of that Law) then its liability for a breach of any such condition or warranty express or implied shall be limited, at its option, to any one or more of the following.
- A in case of Goods
- I the replacement of the Goods or the supply of equivalent Goods.
  - II the repair of the goods,
  - III the payment of the cost of replacing the Goods or acquiring equivalent Goods.
  - IV the payment of the cost of having the Goods repaired. Provided that any such Goods are returned to the Company by the Purchaser at the Purchaser's expense.
- B in the case of services
- I the supply of the services again,
  - II the payment of the cost of having the services supplied again.
- 1.4 The Company is not liable for the costs of recovery of the Goods from the field, loss of use of the Goods, loss of time, inconvenience, incidental or consequential loss or damage, nor for any other loss or damage other than as stated above, whether ordinary or exemplary, caused either directly or indirectly by use of the Goods.
- 1.5 The Company warrants that at the time of shipment, Products manufactured by it will be free from defects in material and workmanship. In the absence of a modified written warranty, the Company agrees to making good any such defects by repairing the same or at the Company's option by replacement, for a period of (1) one year from the date of shipment. This limited warranty applies provided that:
- a defects have arising solely from faulty materials or workmanship;
  - b the Products have not received maltreatment, inattention or interference;
  - c the Products have been installed in accordance with the Company's Installation Handbooks using only products supplied by the Company;
  - d accessories used with the Products are manufactured by or approved by the Company
  - e the Products are maintained in accordance with Australian Standard 1891.4 (section 9).
  - f you notify any claim under this warranty to SafetyLink in writing to the address below no later than 14 days after the event or occurrence concerning the produce giving rise to the claim and you pay all costs related to your claim.
- This warranty does not apply to any defects or other malfunctions caused to the Goods by accident, neglect, vandalism, misuse, alteration, modification or unusual physical, environment or electrical stress.
- Please note that the benefits to the purchaser (as a consumer) given by this warranty are in addition to your other rights and remedies under the Australian Consumer Law. Our goods come with guarantees that cannot be excluded under the Australian Consumer Law. You are entitled to a replacement or refund for a major failure and compensation for any other reasonably foreseeable loss or damage. You are also entitled to have the goods repaired or replaced if the goods fail to be of acceptable quality and the failure does not amount to a major failure.
- 1.6 If any goods are not manufactured by the Company, the guarantee of the manufacturer thereof shall be accepted by the Purchaser as the only express warranty given in respect of the goods.
- 1.7 Except as provided in this clause 11, all express and implied warranties, guarantees and conditions under statute or general law as the merchantability, description, quality, suitability or fitness of the Products for any purpose or as to design, assembly, installation, materials or workmanship or otherwise are hereby expressly excluded (to the extent to which they may be excluded by law).

**PLEASE SEE SAFETYLINK PTY LTD FULL STANDARD TERMS OF CONDITIONS OF SALE FOR FURTHER REFERENCE.**



SafetyLink Pty Ltd | ABN 83 081 777 371 | [www.safetylink.com](http://www.safetylink.com)  
Head Office: 54 Bonville Ave, Thornton, 2322, NSW, Australia  
+64 2 4964 1068 | 1300 789 545  
Asia-Pacific/The Americas | [info@safetylink.com](mailto:info@safetylink.com)  
Europe/Africa/Middle East | [europe.sales@safetylink.com](mailto:europe.sales@safetylink.com)  
Northern Europe | [uk.sales@safetylink.com](mailto:uk.sales@safetylink.com)