



Horizontal Rail System

Installation and Use

FIGURE 1



CONTENTS

1	Warning	4
2	Specification	4
2.1	Description	4
2.2	Standard.....	4
2.3	User Rating	4
2.4	System Substrate.....	4
2.5	Material Specification and Components.....	5
3	Layout and Selection	13
3.1	System Design.....	13
3.2	Spans.....	13
3.3	Over Hang	14
3.4	Joins	14
3.5	Reaction Loads	15
3.5.1	Side Fix System	15
3.5.2	Concealed Fix System	16
3.5.3	Offset Fix System.....	18
3.6	Corner Radius	18
4	Installation	19
4.1	Fixings	19
4.1.1	General	19
4.1.2	Steel (Side and Offset Fix System).....	19
4.1.3	Steel (Concealed Fix).....	19
4.1.4	Concrete 3rd Party	19
4.1.5	Concrete - DonutLink.....	19
4.2	Proof Loading.....	20
4.3	Support Brackets - Ends	21
4.4	Support Brackets - Intermediates.....	22
4.5	Drill Fixture.....	23
4.6	Standard and Low Profile Joins.....	24
4.7	Intermediate Join	25
4.8	Shuttle Stop.....	25
4.9	Gate - Mid Span.....	26
4.10	Gate - End.....	27
4.11	Tuff-Post	27
4.12	BeamLink.....	28
4.13	Steelink.....	28
4.14	Tuff-Bracket.....	28
4.15	Expansion Joins.....	29
4.16	External Corner Assemblies (Wall Mounted).....	31
4.16.1	Side Fix	31
4.16.2	Concealed Fix (Parallel)	32
4.16.3	Concealed Fix (Perpendicular).....	33
4.16.4	Concealed Fix (no jogs)	34
4.16.5	Offset Fix	35

4.17	Internal Corner Assemblies (Wall Mounted)	36
4.17.1	Side Fix	36
4.17.2	Concealed Fix.....	37
4.17.3	Offset Fix	38
4.18	Corner Assemblies (Floor or Overhead Mounted)	39
4.18.1	Side Fix	39
4.18.2	Concealed Fix.....	40
4.18.3	Offset Fix (Floor Only)	41
5	Limitations of Use	42
5.1	Fall Clearance	42
5.2	Swing Fall	42
5.3	Area of Use	43
5.4	Hazards	43
5.5	Training	43
5.6	Rescue	43
6	Connections	44
6.1	Making Connections	44
6.2	Compatibility of Connections	44
7	Use	45
7.1	Planning	45
7.2	X-Rail Gate operation	45
7.2.1	End Gate	45
7.2.2	Intermediate Gate	46
7.3	Shuttle Operation	47
7.4	Single Point Anchor	48
7.4.1	Operation.....	48
7.4.2	Limitations.....	48
7.4.3	Installation.....	49
8	Storage, Transport and Maintenance	50
8.1	Storage and Transport	50
8.2	Maintenance	50
8.3	Cleaning	50
9	Inspection	50
9.1	Before and After Use	50
9.2	Competent Person	50
9.3	Procedure	50

1 Warning

- ⚠ Improper Use, Installation or Maintenance may result in serious injury or death.**
- ⚠ The structure or anchorage to which SafetyLink products are to be installed shall be assessed by a professional engineer to ensure it has adequate strength to support the product.**
- ⚠ SafetyLink products shall be installed, used and maintained in accordance with the applicable SafetyLink installation and use manual.**
- ⚠ SafetyLink's product shall be used in accordance with the current working at height standards, codes of practice, regulation or legislation in the region of use.**
- ⚠ During installation, use and maintenance, personnel shall not be exposed to a fall hazard.**
- ⚠ Installation is to be carried out by, or under the supervision of, a competent person.**
- ⚠ The installer shall complete the applicable SafetyLink online training modules before installing this product.**
- ⚠ Connection systems used with SafetyLink Anchor, Lifelines and Rigid Rail Systems shall contain a personal energy absorber.**
- ⚠ Do not carry out any modifications to this product without written permission from SafetyLink.**

2 Specification

2.1 Description

The X-Rail is a Horizontal Rail System suitable for use as part of a personal fall protection system. The system comprises a permanently installed horizontal rail profile with a number of shuttles for users to attach. The shuttles are free to traverse the length of the rail.

2.2 Standard

The X-Rail Horizontal Rail System is compliant with AS/NZS 1891.2, EN795 and CEN/TS16415.

2.3 User Rating

The X-Rail is rated for up to 4 users with a maximum weight of 150kg.

- ⚠ Never connect more than one user to each shuttle.**

2.4 System Substrate

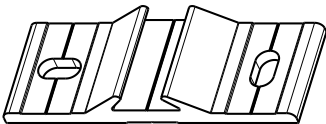
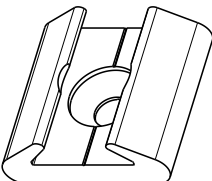
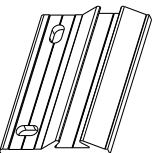
FIGURE 2		
IMAGE	SYSTEM	SUBSTRATE
	Side Fix System	General purpose system designed for easiest installation on steel or concrete structures.
	Concealed Fix System	Concealed fastener system with all fasteners installed behind the rail. Access to behind the substrate is required for some brackets. Suitable for installation on steel structures.
	Offset Fix System	Ideal for installation into the end of thin concrete slab (min 200mm) or on the floor with minimal edge distance. Can be installed in steel and concrete.

2.5 Material Specification and Components

FIGURE 3

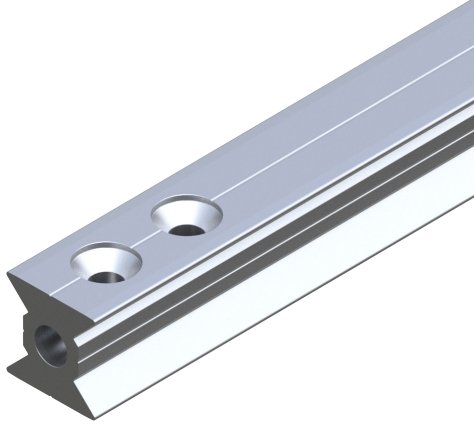

XRAIL-TR-101-6M-T6A
RAIL SECTION

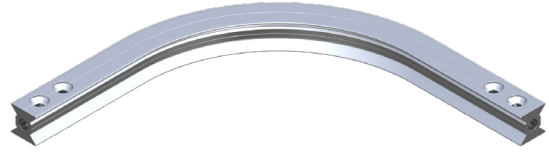

XRAIL-TR-104
FLOOR/OVERHEAD CORNER 90°

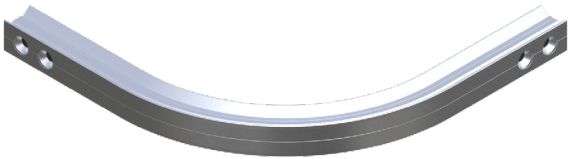

XRAIL-TR-105
EXTERNAL CORNER 90°

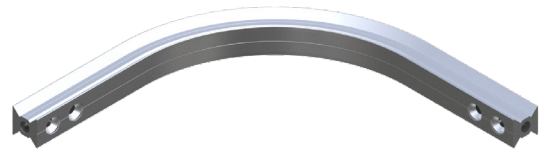

XRAIL-TR-106
INTERNAL CORNER 90°

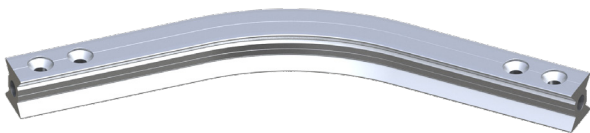

XRAIL-TR-107
FLOOR/OVERHEAD CORNER 45°

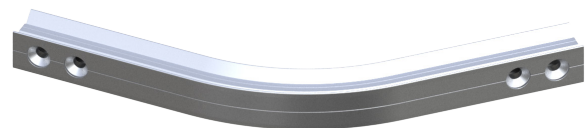

XRAIL-TR-108
EXTERNAL CORNER 45°

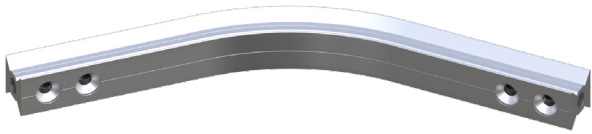

XRAIL-TR-109
INTERNAL CORNER 45°

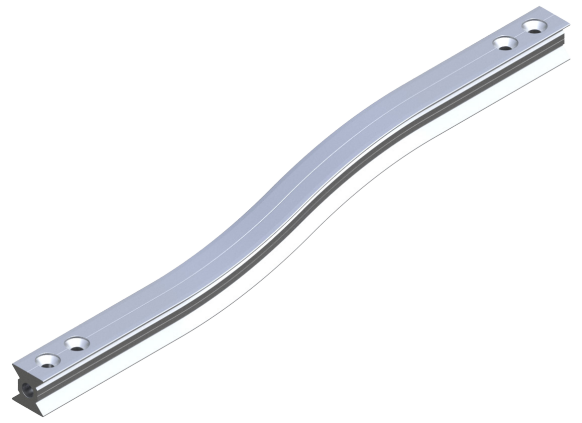

XRAIL-TR-110
JOG

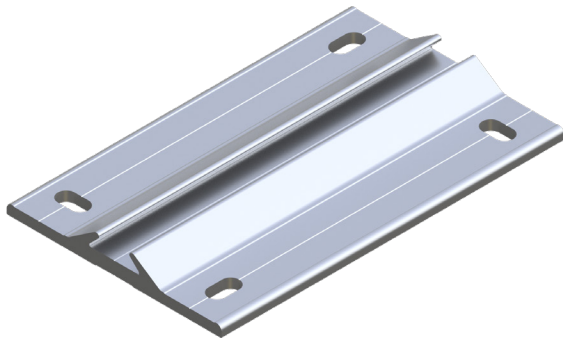

XRAIL-TR-203
SIDE FIX END BRACKET

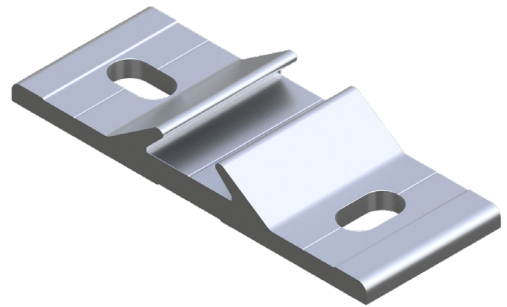

XRAIL-TR-204
SIDE FIX INTERMEDIATE BRACKET

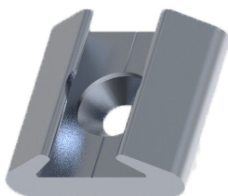

XRAIL-TR-201
CONCEALED FIX INTERMEDIATE AND END BRACKET

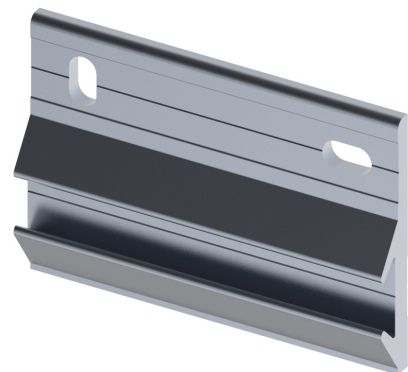

XRAIL-TR-230
OFFSET FIX INTERMEDIATE AND END BRACKET

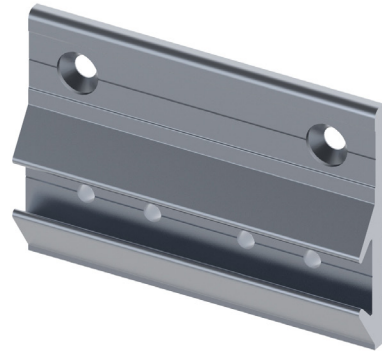
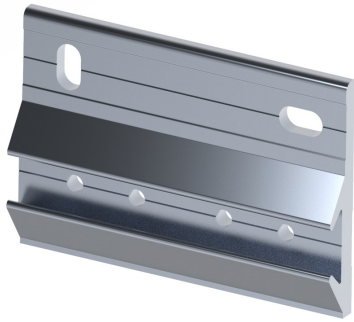

XRAIL-TR-231
OFFSET FIX JOIN BRACKET

XRAIL-TR-232
OFFSET FIX EXTERNAL CORNER JOIN BRACKET

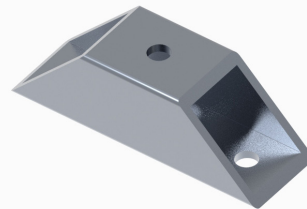
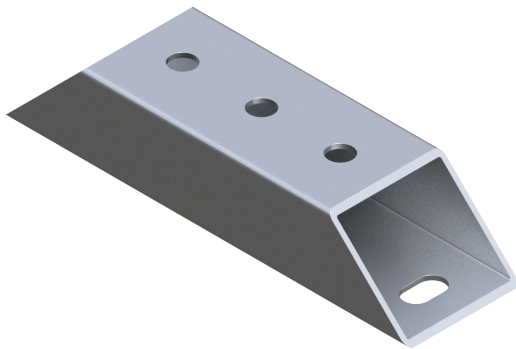

XRAIL-TR-216
SIDE FIX EXTERNAL BRACKET

XRAIL-TR-235
CONCEALED FIX EXTERNAL BRACKET



XRAIL-TR-234
OFFSET FIX EXTERNAL BRACKET

XRAIL-TR-206
RAIL JOIN

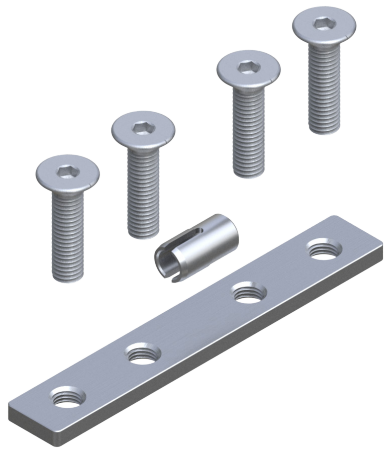

XRAIL-TR-005

LOW PROFILE RAIL JOIN

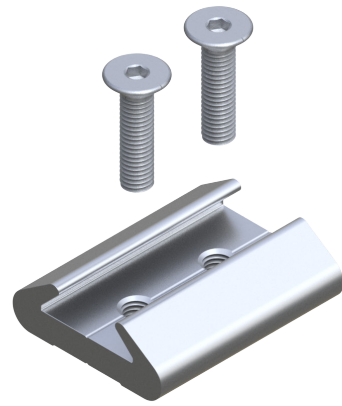

XRAIL-TR-008

SYSTEM TERMINATION

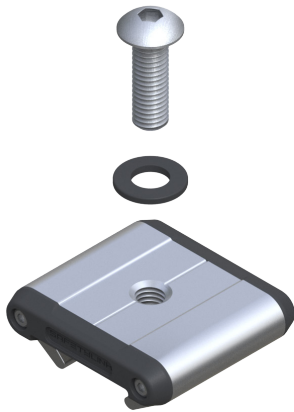

XRAIL-TR-006

SHUTTLE STOP

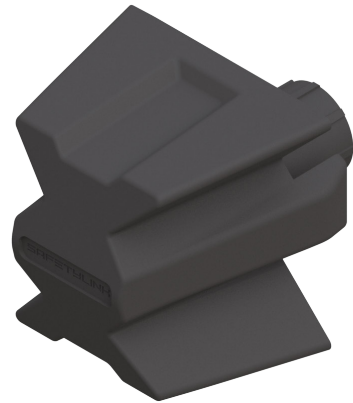

XRAIL-TR-213

RAIL END CAP

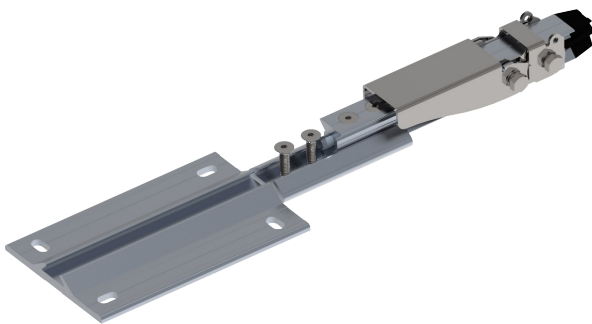

NO BRACKETS

XRAIL-TR-GATE.KIT

SIDE FIX

XRAIL-TR-GATE.KITSF

CONCEALED FIX

XRAIL-TR-GATE.KITCF

END RAIL GATE

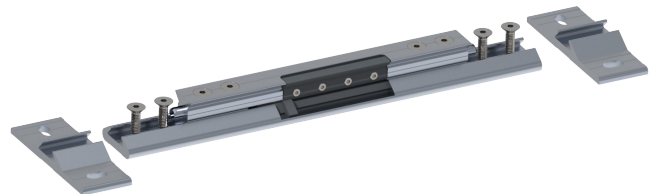

NO BRACKETS

XRAIL-TR-GATE.INT

SIDE FIX

XRAIL-TR-GATE.INT.KITSF

**CONCEALED
FIX**

XRAIL-TR-GATE.INT.KITCF

INTERMEDIATE RAIL GATE

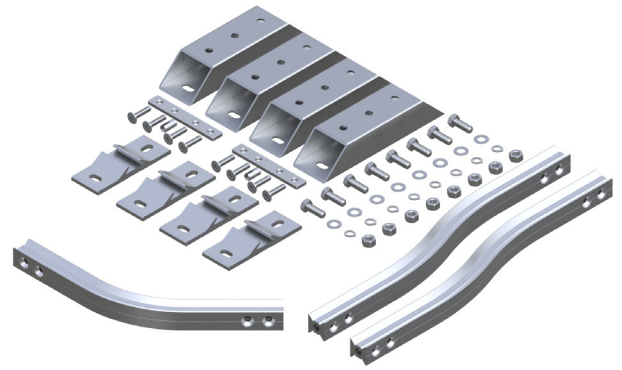
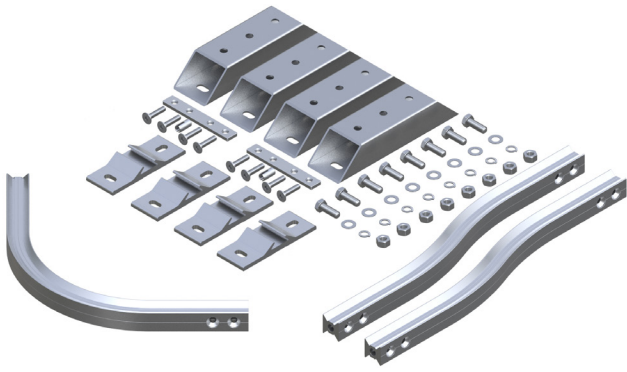

90° DEGREE CORNER KITS

45° DEGREE CORNER KITS

System	Type	90°	45°
Side Fix	Floor/Overhead	XRAIL-TR-031	XRAIL-TR-032
Side Fix	Internal	XRAIL-TR-028	XRAIL-TR-029
Side Fix	External	XRAIL-TR-020	XRAIL-TR-021
Concealed Fix	Floor/Overhead	XRAIL-TR-038	XRAIL-TR-039
Concealed Fix	Internal	XRAIL-TR-035	XRAIL-TR-036
Concealed Fix	External	XRAIL-TR-023	XRAIL-TR-024
Offset Fix	Internal	XRAIL-TR-056	XRAIL-TR-057
Offset Fix	External	XRAIL-TR-053	XRAIL-TR-054

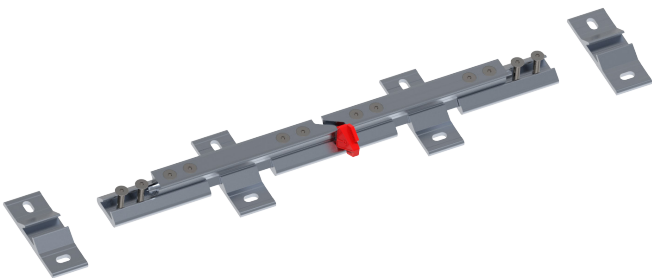

NO BRACKETS	XRAIL-TR-236	XRAIL-TR-011
SIDE FIX	XRAIL-TR-042	
CONCEALED FIX	XRAIL-TR-044	
EXPANSION JOIN		RAIL SHUTTLE



XRAIL-TR-014
RAIL SHUTTLE



XRAIL-TR-017
RAIL SHUTTLE



XRAIL-TR-017A
RAIL SHUTTLE

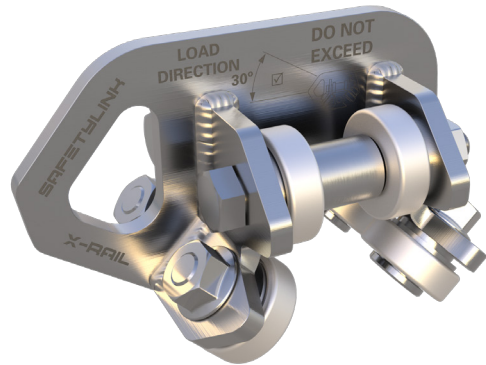

XRAIL-TR-018
RAIL SHUTTLE



XRAIL-TR-SPA
SINGLE POINT ANCHOR

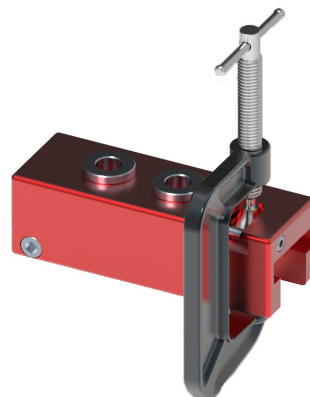

XRAIL-TR-402
DRILL FIXTURE



**XRAIL-TR-401
DRILL BIT**



**DONUTLINK-ADP
DONUT TEST ADAPTOR**



**CON-M12X160-XDONUT
CONCRETE STUD**

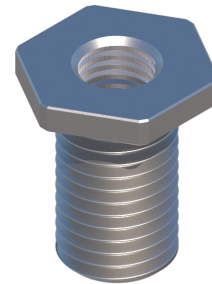

**ADAPTER M12-M16
TUFF-POST ADAPTOR**

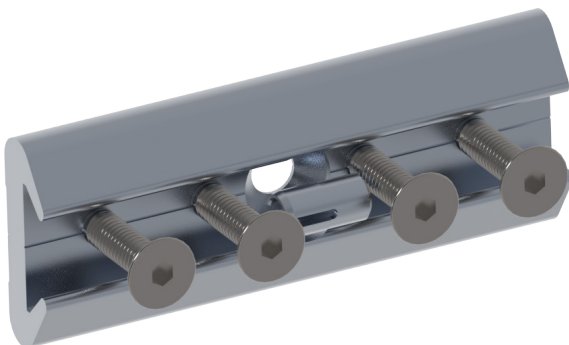

**XRAIL-TR-060
INTERMEDIATE JOIN KIT, CONCEALED FIX**

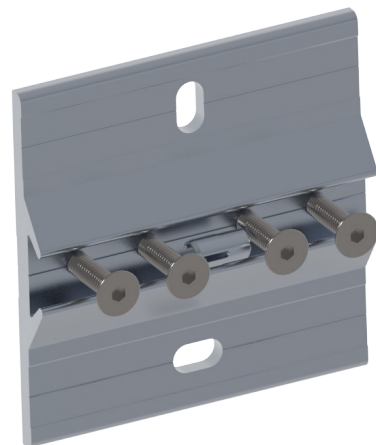

**XRAIL-TR-061
INTERMEDIATE JOIN KIT, SIDE FIX**

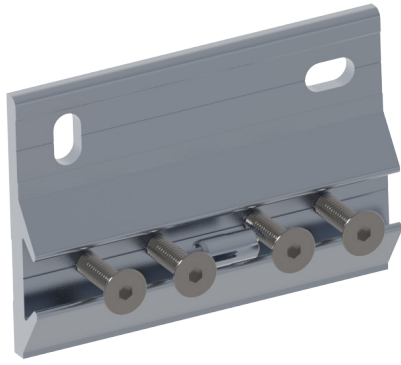

XRAIL-TR-062

INTERMEDIATE JOIN KIT, OFFSET FIX

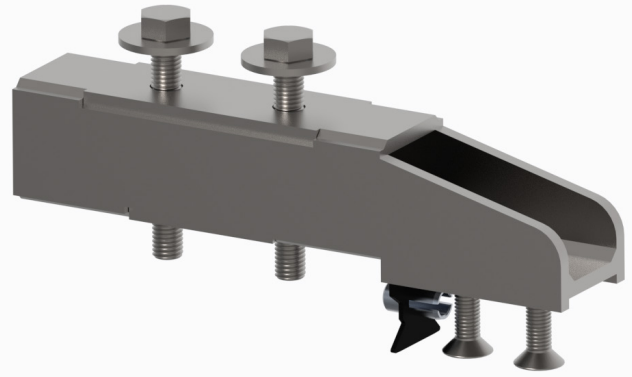

XRAIL-U-XTX

X-RAIL TO X-RAIL ULTRA JOIN

3 Layout and Selection

3.1 System Design

Systems shall be designed to limit free fall, swing fall and maximise fall clearance. Where possible, systems should be designed to prevent a free fall from occurring.

The X-Rail Horizontal Rail System shall be installed on an angle no greater than 5°.

All dimensions unless stated as min or max are ±5mm.

3.2 Spans

The below Figure 4 shows the maximum allowable spans for the different support bracket configurations.

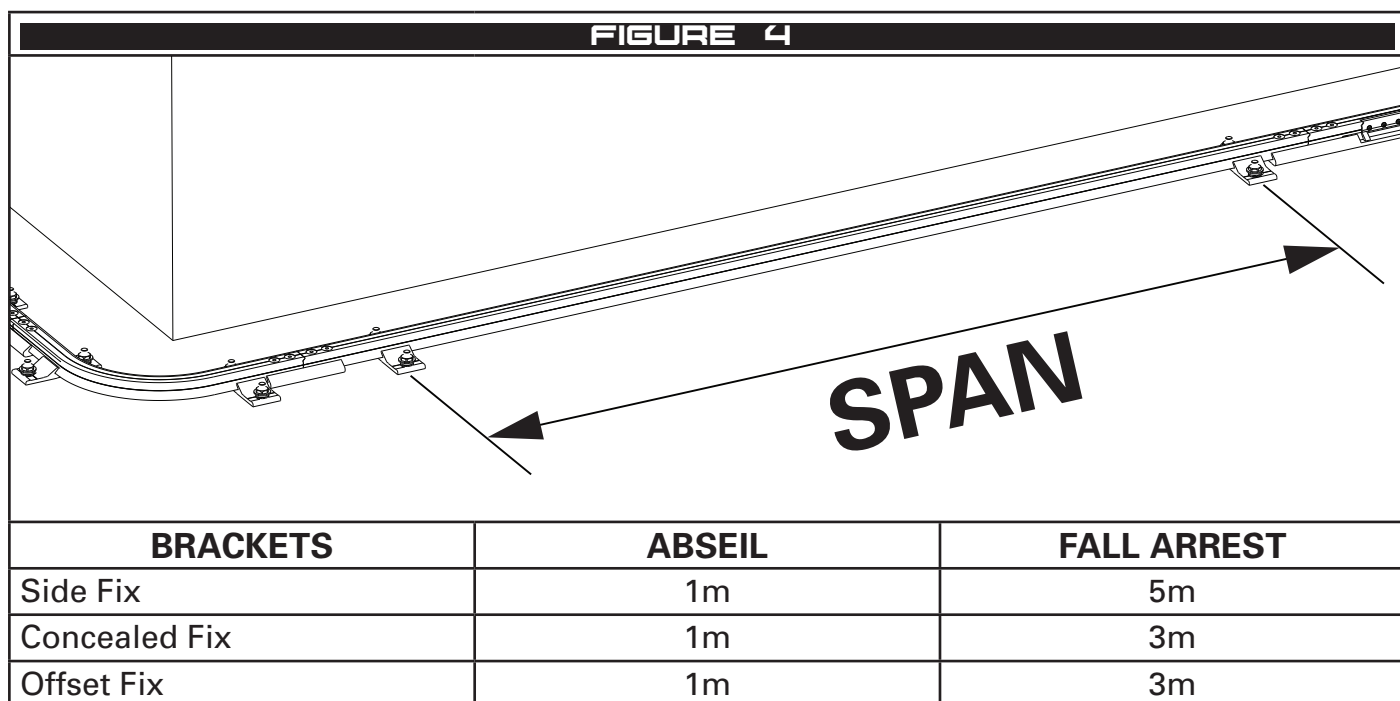
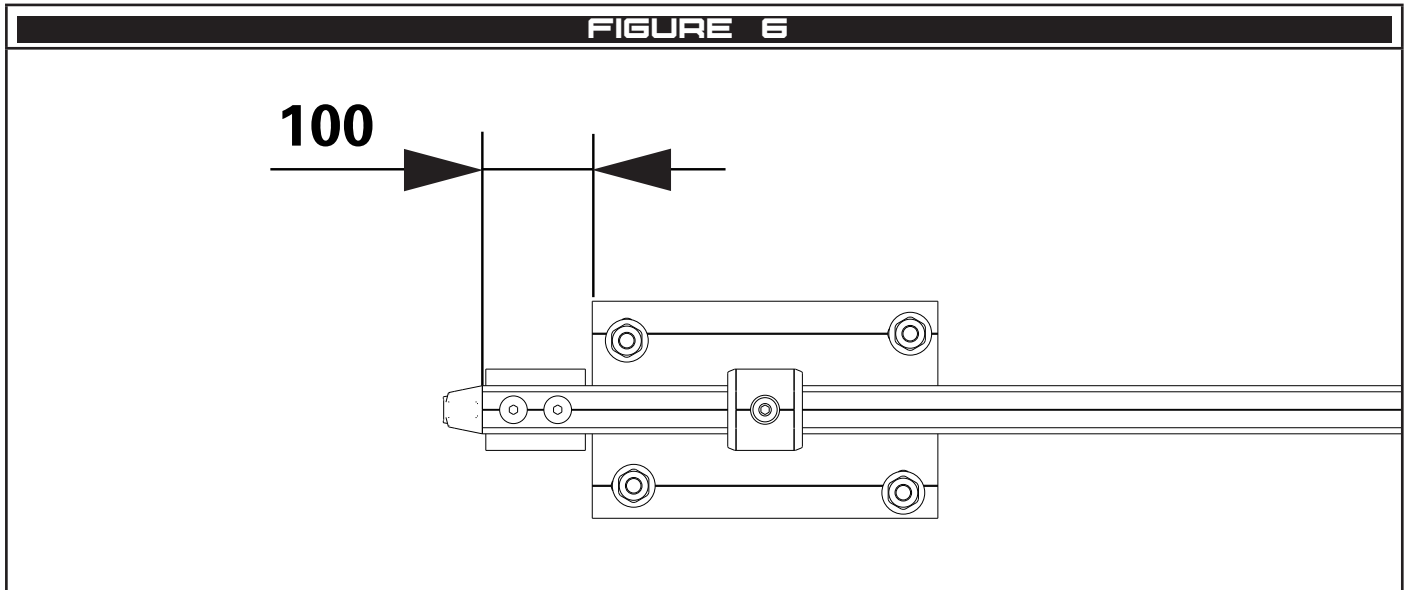

FIGURE 5

SPAN LENGTH (mm)	MAXIMUM DEFLECTION (mm) (4 USERS)
1000	50
2000	130
3000	180
4000	220
5000	250

3.3 Over Hang

The rail shall not overhang the end bracket more than 100mm.



3.4 Joins

Standard and low profile joins shall be installed between 2 intermediate brackets, no greater than 309mm apart.

- ✓ For the Side and Concealed Fix system this measurement is taken from the centre line of the bracket or location of the fastener.
- ✓ For the Offset Fix system this measurement is taken between the 2 closest fasteners.
- ✓ Intermediate Joins (4.7) do not require a bracket either side.

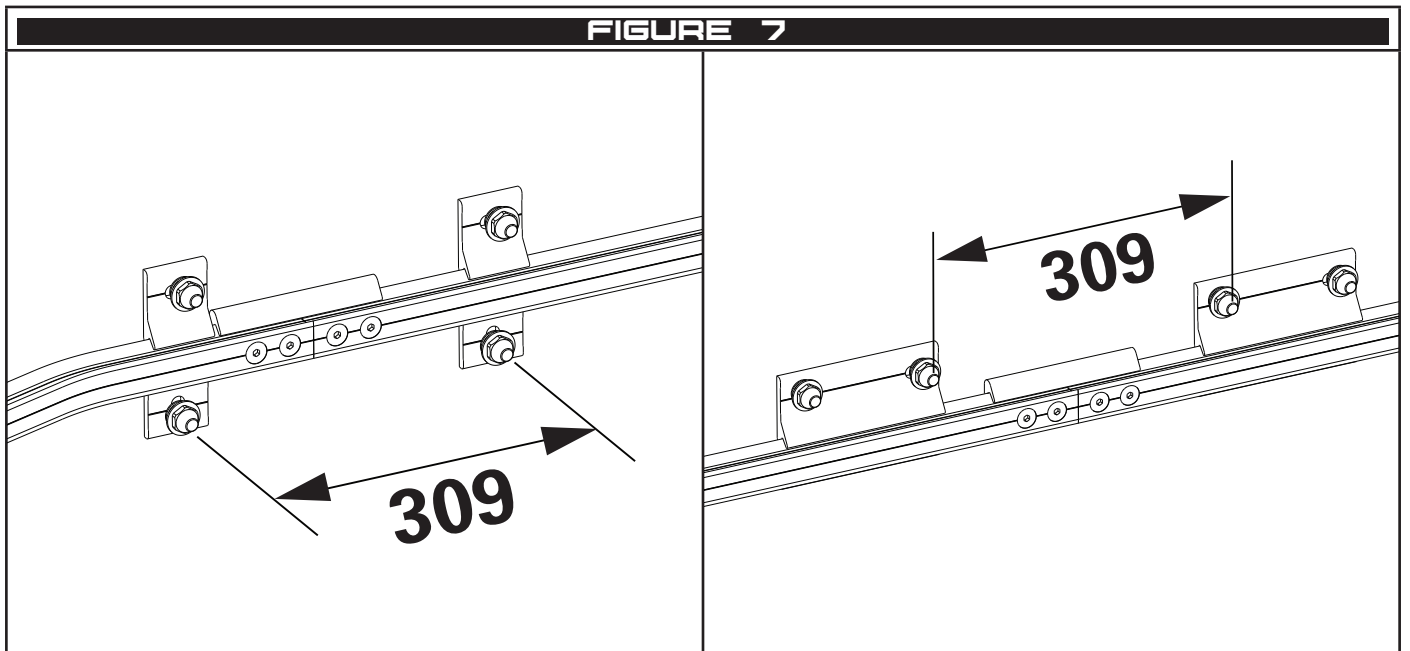

3.5 Reaction Loads

The supporting structure and fixings used shall be capable of sustaining the below load cases where applicable. Case 1 represents loading of the system over the bracket. Case 2 represents loading of the system at the centre of the adjacent span.

! All load cases shall be considered by a trained engineer.

! The below cases represent the standard installation configurations, specific installations may require additional load case investigation.

3.5.1 Side Fix System

FIGURE 8		
	<p>Case 1</p> <p>Yaw - 0kNm</p> <p>Shear - 15kN</p> <p>Roll - 0.675kNm</p>	<p>Case 2</p> <p>Yaw - 1.4kNm</p> <p>Shear - 7.5kN</p> <p>Roll - 0.3375kNm</p>
WALL MOUNTED INTERMEDIATE BRACKET		
	<p>Case 1</p> <p>Yaw - 0kNm</p> <p>Shear - 15kN</p> <p>Roll - 0.675kNm</p>	<p>Case 2</p> <p>Yaw - 1.4kNm</p> <p>Shear - 7.5kN</p> <p>Roll - 0.3375kNm</p>
WALL MOUNTED END BRACKET		
	<p>Yaw - 1.25kNm</p> <p>Shear - 7.5kN</p> <p>Roll - 0.7125kNm</p>	
WALL MOUNTED EXTERNAL CORNER BRACKET		
	<p>Case 1</p> <p>Yaw - 0kNm</p> <p>Shear - 15kN</p> <p>Roll - 0.675kNm</p>	<p>Case 2</p> <p>Yaw - 1.4kNm</p> <p>Shear - 7.5kN</p> <p>Roll - 0.3375kNm</p>
FLOOR MOUNTED INTERMEDIATE BRACKET		

<p>YAW</p> <p>SHEAR</p> <p>ROLL</p>	<p>Case 1</p> <p>Yaw - 0kNm</p> <p>Shear - 15kN</p> <p>Roll - 0.675kNm</p>	<p>Case 2</p> <p>Yaw - 1.4kNm</p> <p>Shear - 7.5kN</p> <p>Roll - 0.3375kNm</p>
FLOOR MOUNTED END BRACKET		
<p>PULL</p> <p>PITCH</p>	<p>Case 1</p> <p>Pitch - 0kNm</p> <p>Pull - 15kN</p>	<p>Case 2</p> <p>Pitch - 1.4kNm</p> <p>Pull - 7.5kN</p>
OVERHEAD MOUNTED INTERMEDIATE BRACKET		
<p>PULL</p> <p>PITCH</p>	<p>Case 1</p> <p>Pitch - 0kNm</p> <p>Pull - 15kN</p>	<p>Case 2</p> <p>Pitch - 1.4kNm</p> <p>Pull - 7.5kN</p>
OVERHEAD MOUNTED END BRACKET		

3.5.2 Concealed Fix System

FIGURE 9		
<p>SHEAR</p> <p>ROLL</p>	<p>Shear - 15kN</p> <p>Roll - 0.675kNm</p>	
WALL MOUNTED INTERMEDIATE BRACKET		
<p>SIDE</p> <p>SHEAR</p> <p>ROLL</p>	<p>Case 1</p> <p>Side - 0kNm</p> <p>Shear - 15kN</p> <p>Roll - 0.675kNm</p>	<p>Case 2</p> <p>Side - 7.5kN</p> <p>Shear - 7.5kN</p> <p>Roll - 0.3375kNm</p>
WALL MOUNTED END BRACKET		

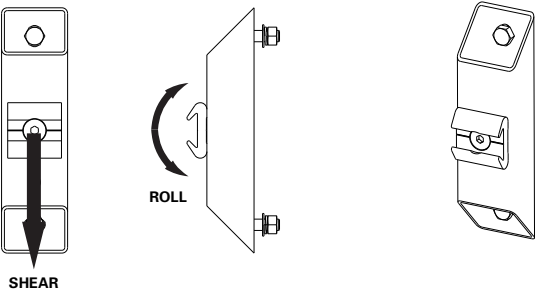
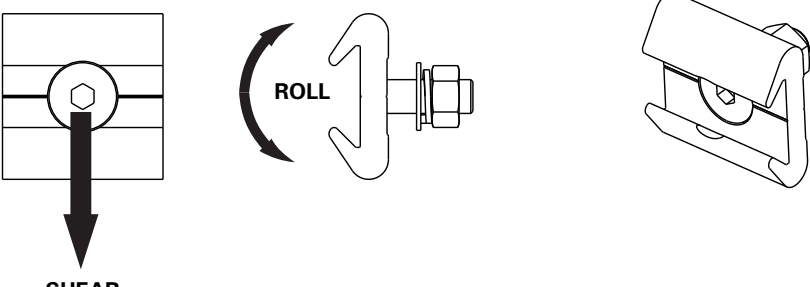
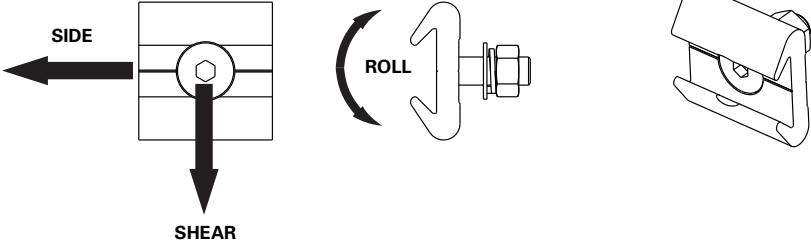
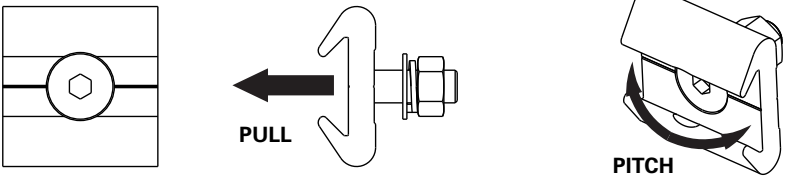
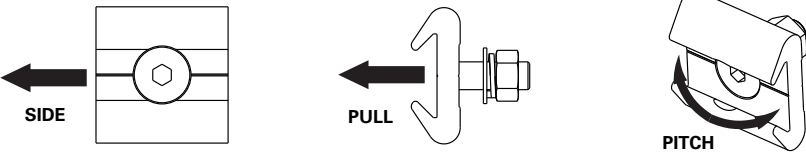
 <p style="text-align: center;">SHEAR</p> <p style="text-align: center;">ROLL</p>	<p>Shear - 7.5kN</p> <p>Roll - 0.7125kNm</p>	
WALL MOUNTED EXTERNAL CORNER BRACKET		
 <p style="text-align: center;">SHEAR</p> <p style="text-align: center;">ROLL</p>	<p>Shear - 15kN</p> <p>Roll - 0.675kNm</p>	
FLOOR MOUNTED INTERMEDIATE BRACKET		
 <p style="text-align: center;">SIDE</p> <p style="text-align: center;">SHEAR</p> <p style="text-align: center;">ROLL</p>	<p>Case 1</p> <p>Side - 0kNm</p> <p>Shear - 15kN</p> <p>Roll - 0.675kNm</p>	<p>Case 2</p> <p>Side - 7.5kN</p> <p>Shear - 7.5kN</p> <p>Roll - 0.3375kNm</p>
FLOOR MOUNTED END BRACKET		
 <p style="text-align: center;">PULL</p> <p style="text-align: center;">PITCH</p>	<p>Case 1</p> <p>Pitch - 0kNm</p> <p>Pull - 15kN</p>	<p>Case 2</p> <p>Pitch - 1.4kNm</p> <p>Pull - 7.5kN</p>
OVERHEAD MOUNTED INTERMEDIATE BRACKET		
 <p style="text-align: center;">SIDE</p> <p style="text-align: center;">PULL</p> <p style="text-align: center;">PITCH</p>	<p>Case 1</p> <p>Pitch - 0kNm</p> <p>Pull - 15kN</p> <p>Side - 0kN</p>	<p>Case 2</p> <p>Pitch - 1.4kNm</p> <p>Pull - 7.5kN</p> <p>Side - 15kN</p>
OVERHEAD MOUNTED END BRACKET		

3.5.3 Offset Fix System

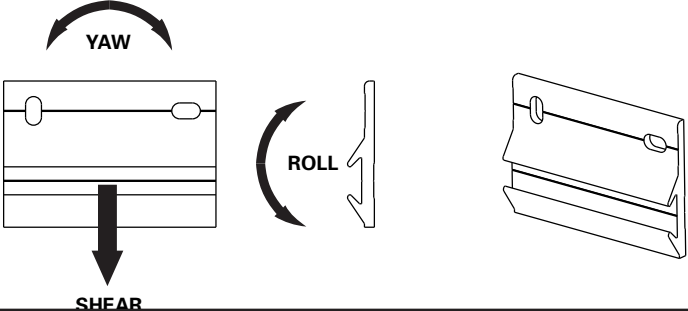
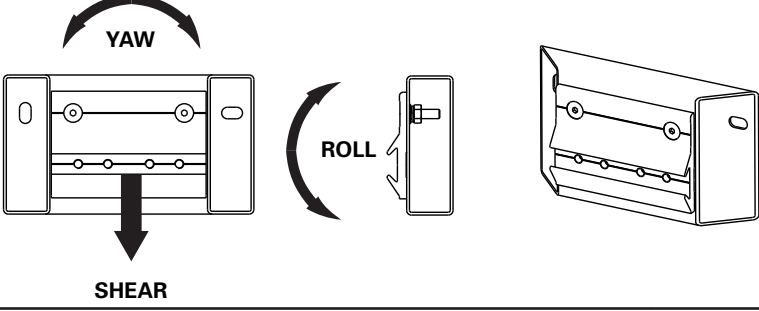
FIGURE 10		
 <p>The diagram shows a side view of a bracket with two screws. A curved arrow labeled 'YAW' is above it, a downward arrow labeled 'SHEAR' is below it, and a curved arrow labeled 'ROLL' is to its right. A perspective view of the bracket is shown to the right.</p>	<p>Case 1 Yaw - 0kNm Shear - 15kN Roll - 0.675kNm</p>	<p>Case 2 Yaw - 1.4kNm Shear - 7.5kN Roll - 0.3375kNm</p>
WALL MOUNTED INTERMEDIATE AND END BRACKET		
 <p>The diagram shows a side view of a corner bracket with four screws. A curved arrow labeled 'YAW' is above it, a downward arrow labeled 'SHEAR' is below it, and a curved arrow labeled 'ROLL' is to its right. A perspective view of the corner bracket is shown to the right.</p>	<p>Yaw - 1.25kNm Shear - 7.5kN Roll - 0.7125kNm</p>	
WALL MOUNTED EXTERNAL CORNER BRACKET		

3.6 Corner Radius

The minimum centre line radius of a corner is 200mm.

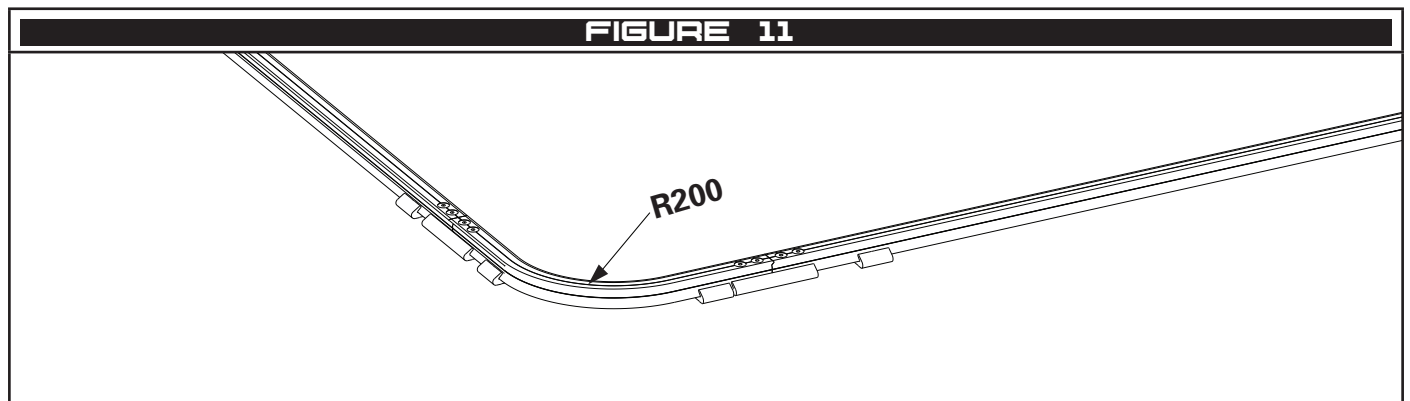

4 Installation

4.1 Fixings

4.1.1 General

All fixings used to attached the X-Rail system to the substrate that were not supplied by SafetyLink shall be M12 (1/2") in diameter. Fixings shall be stainless steel grade 316 or 304 or hot dip galvanised or zinc plated steel grades 8.8 or 8. Fixings shall be installed with spring washers, lock nuts or thread lock adhesive to prevent loosening.

⚠ SafetyLink does not recommended the use of zinc plated fasteners in a corrosive or outdoor environment.

4.1.2 Steel (Side and Offset Fix System)

For installation on a steel structure, SafetyLink recommends the use of appropriate hex head screws or bolts meeting the requirements of section 4.1.1. Fixing shall be tightened to 70Nm and once tight, a minimum of 2 threads shall extend past the end of the nut. Edge distance shall not be less than 29mm to ensure the bracket is seated on the steel structure.

4.1.3 Steel (Concealed Fix)

For installation on a steel structure, SafetyLink recommends the use of the supplied countersunk cap screw, suitable for installation in steel up to 12mm thick. If this is unsuitable an appropriate countersunk cap screw meeting the requirements of section 4.1.1 may be used. Fixing shall be tightened to 40Nm and once tight, a minimum of 2 thread shall extend past the end of the nut. In locations where the fixing cannot be tightened prior to the rail being installed in the bracket, we recommend a suitable adhesive be applied below the screws head to prevent the screw from spinning while the screw is being tightened. Edge distance shall not be less than 29mm to ensure the bracket is seated on the steel structure.

4.1.4 Concrete 3rd Party

In addition to the part numbers specified in Section 4.1.5, SafetyLink allows the use of a variety of chemical and mechanical fixings for installation of the X-Rail Horizontal Rail System into concrete. Refer to the manufacturer's instruction for proper preparation, installation, edge distance and embedded depth.

4.1.5 Concrete - DonutLink

SafetyLink's DonutLink M12 Concrete Stud CON-M12X160-XDONUT are to be installed with chemical adhesive CON-CHEM-FISV.300.

⚠ Check the use by date on the adhesive.

- 1 Mark the location for the hole and drill a Ø14mm hole to the a depth of 95mm (95mm depth must be into structural concrete). See Figure 13 for allowable edge distances.
- 2 Clean the hole, ensuring it is free of moisture and dust and inject the adhesive into the hole as per the manufacturer's instruction.
- 3 Insert the stud to full depth. Wipe away any adhesive expelled from the hole. The top of the stud shall sit at least 35mm from the surface of the concrete.

⚠ Ensure enough adhesive was used, the adhesive should finish flush with the concrete.

- 4 Once the adhesive is cured, install the spring washer and tighten the Donut to 50Nm. The top of the stud may be cut down to leave a minimum of 2 threads exposed.

The DonutLink can be proof loaded with the Pull Test Adaptor (DONUTLINK-ADP) and a Hydrajaws portable tension tester.

FIGURE 12

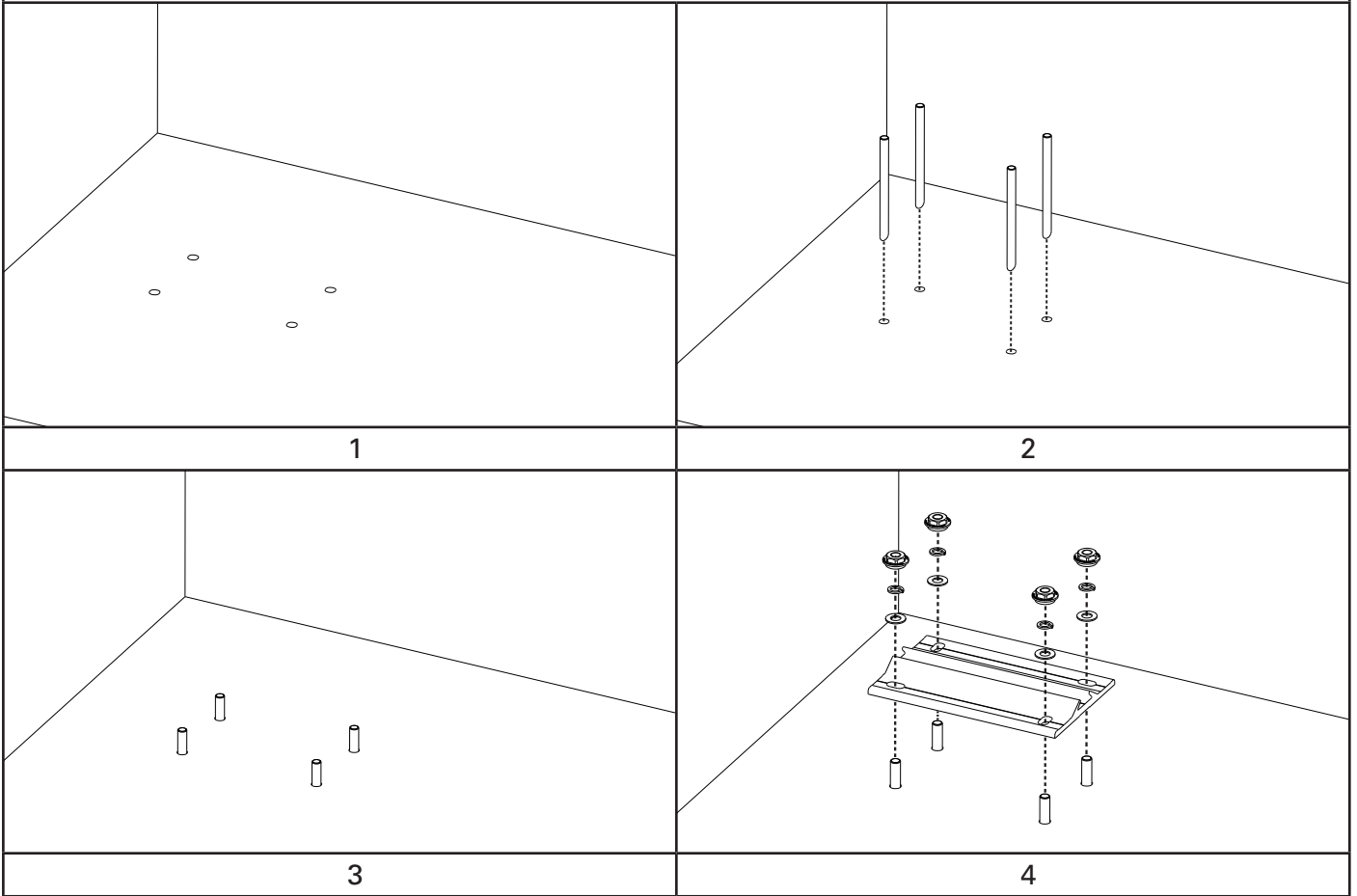

⚠ For additional corner edge distances see Section 4.16

FIGURE 13

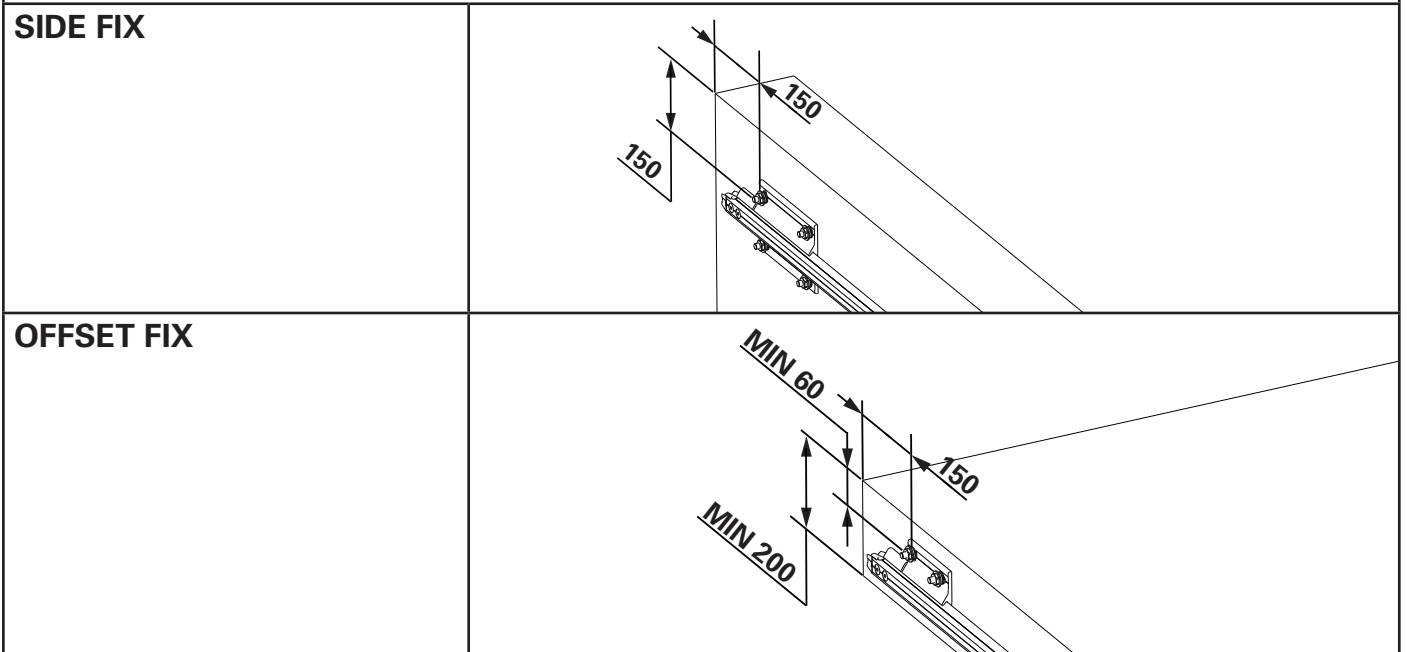

4.2 Proof Loading

Each bolt shall be axial loaded to 7.5kN and held for 30 seconds.

⚠ Proof loading is only required for chemical and mechanical fixed bases as per AS/NZS1891.4.

4.3 Support Brackets - Ends

- 1 Place the bracket over the studs or bolting location and install the fasteners including washers and spring washers.
- 2 Insert the rail through the bracket and fix in place with two rail screws through the rail into the system termination block. The gap between the system termination and bracket shall not exceed 30mm. Install the rail end cap.

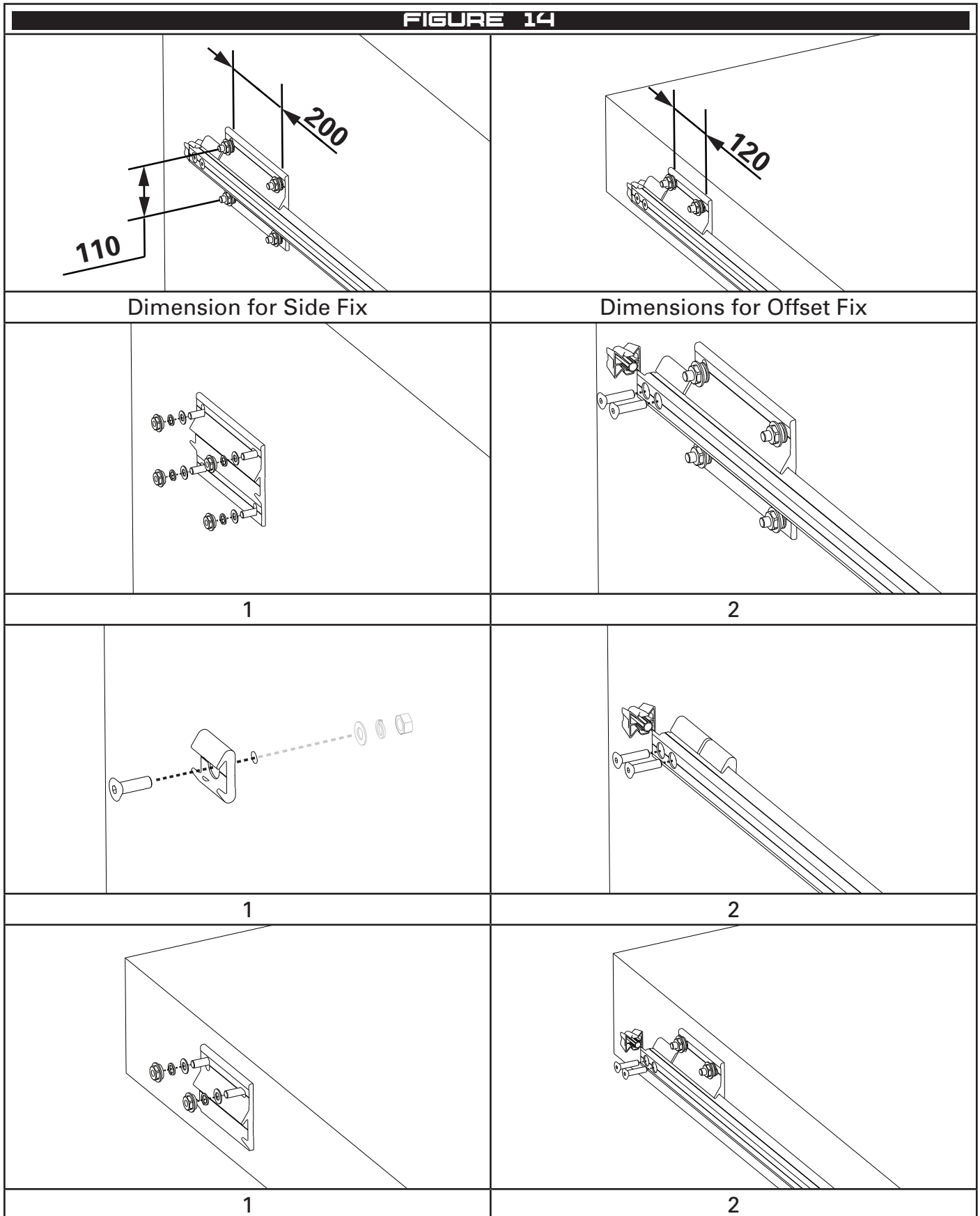

4.4 Support Brackets - Intermediates

- 1 Place the bracket over the studs or bolting location and install the fasteners including washers and spring washers.
- 2 Insert the rail through the bracket.

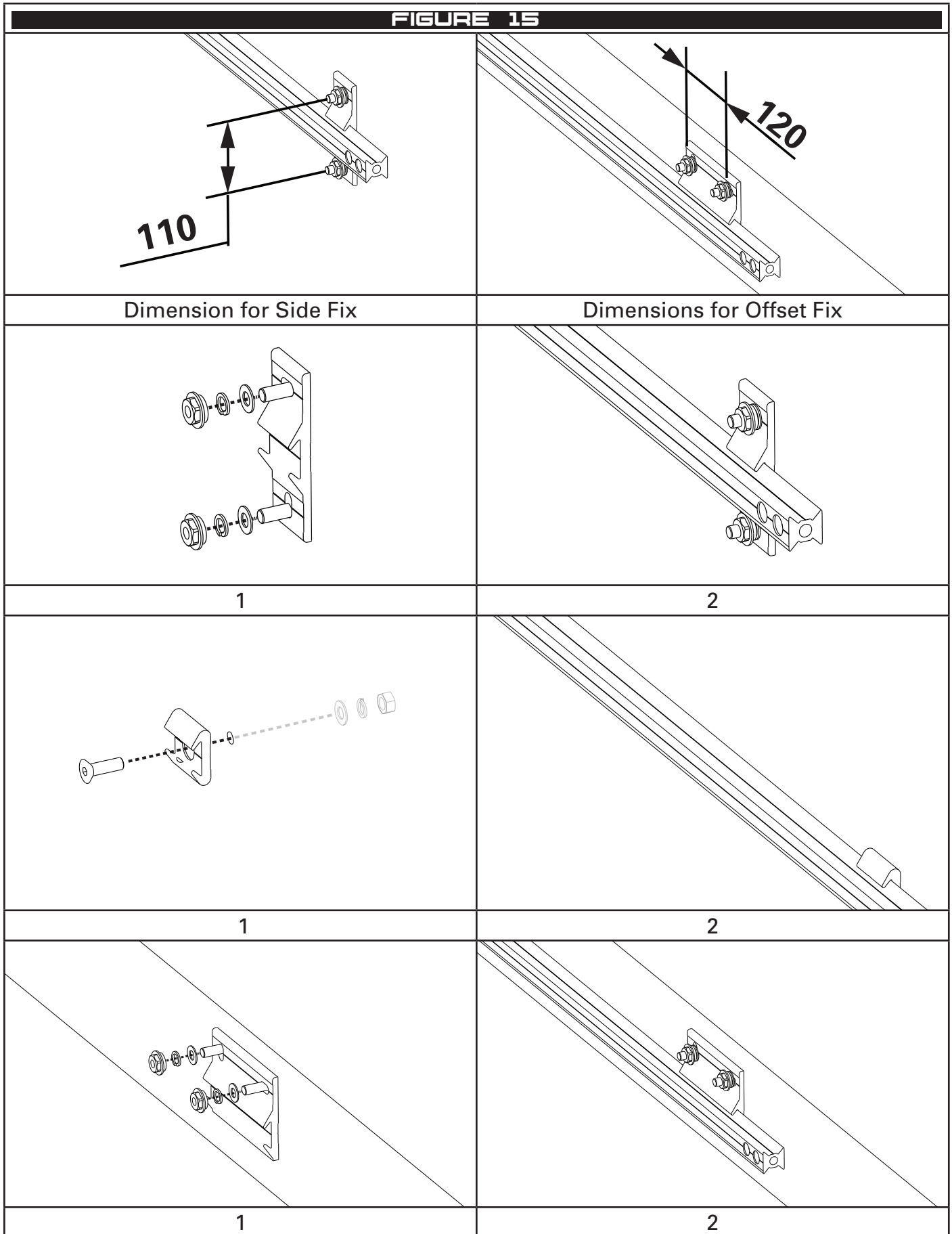

4.5 Drill Fixture

- 1 To drill holes in the rail for joins and system terminations, slide the drill fixture onto the rail until the stop hits the end of the rail and tighten with the clamp.
- 2 With drill bit XRAIL-TR-401, drill to a depth of about 5mm through each of the bushes in the drill fixture.
- 3 Remove the fixture and complete each hole but drill till the countersink portion of the bit is about 2mm below the surface of the rail.

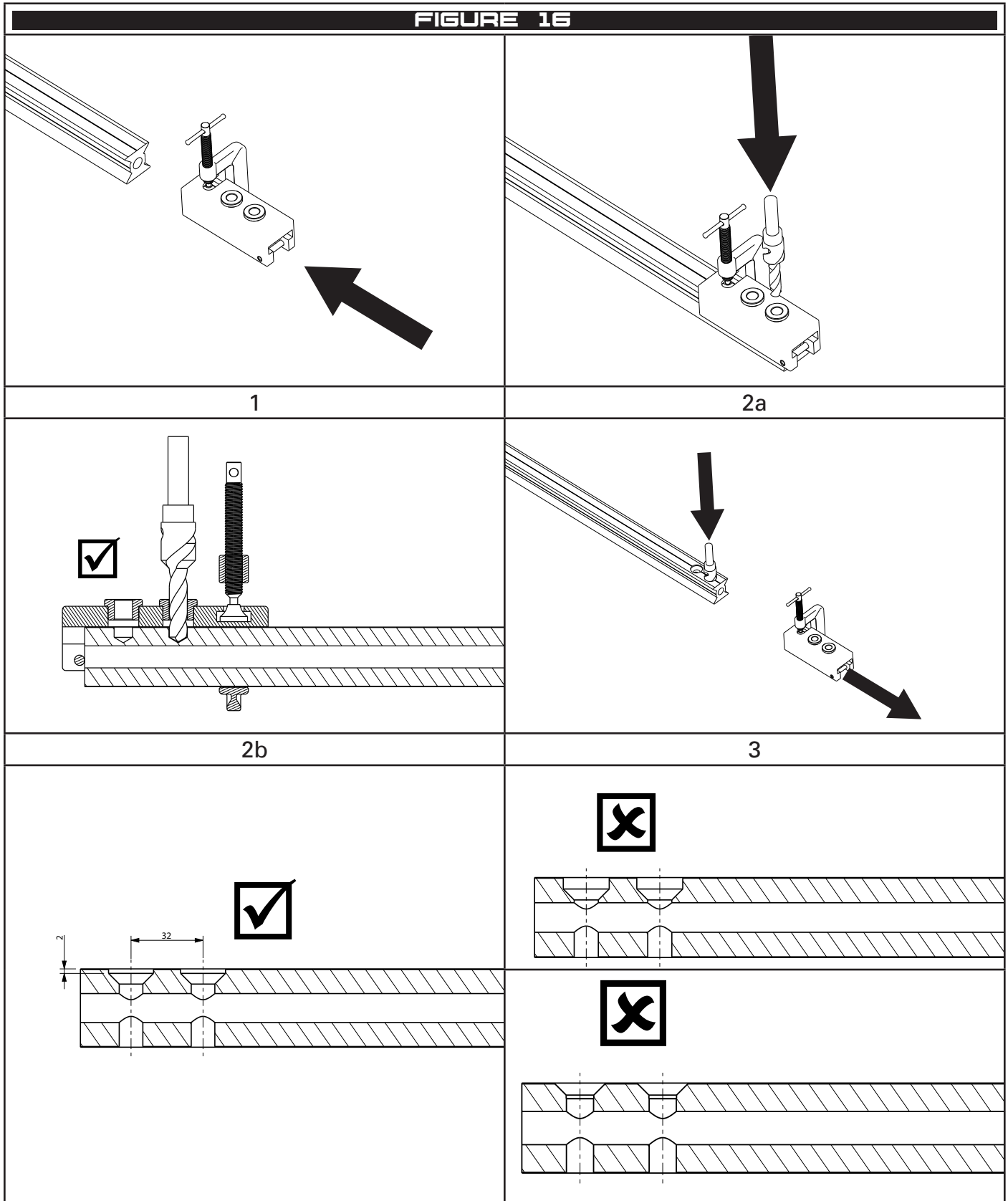

4.6 Standard and Low Profile Joins

- 1 Install the rail through the first bracket and install the dowel (split end first) with a rubber mallet.
- 2 Slide the join block into the end of the rail and fasten with 2 rail screws.
- 3 Install the second piece of rail through the second bracket and into the join block. Fasten with 2 rail screws.

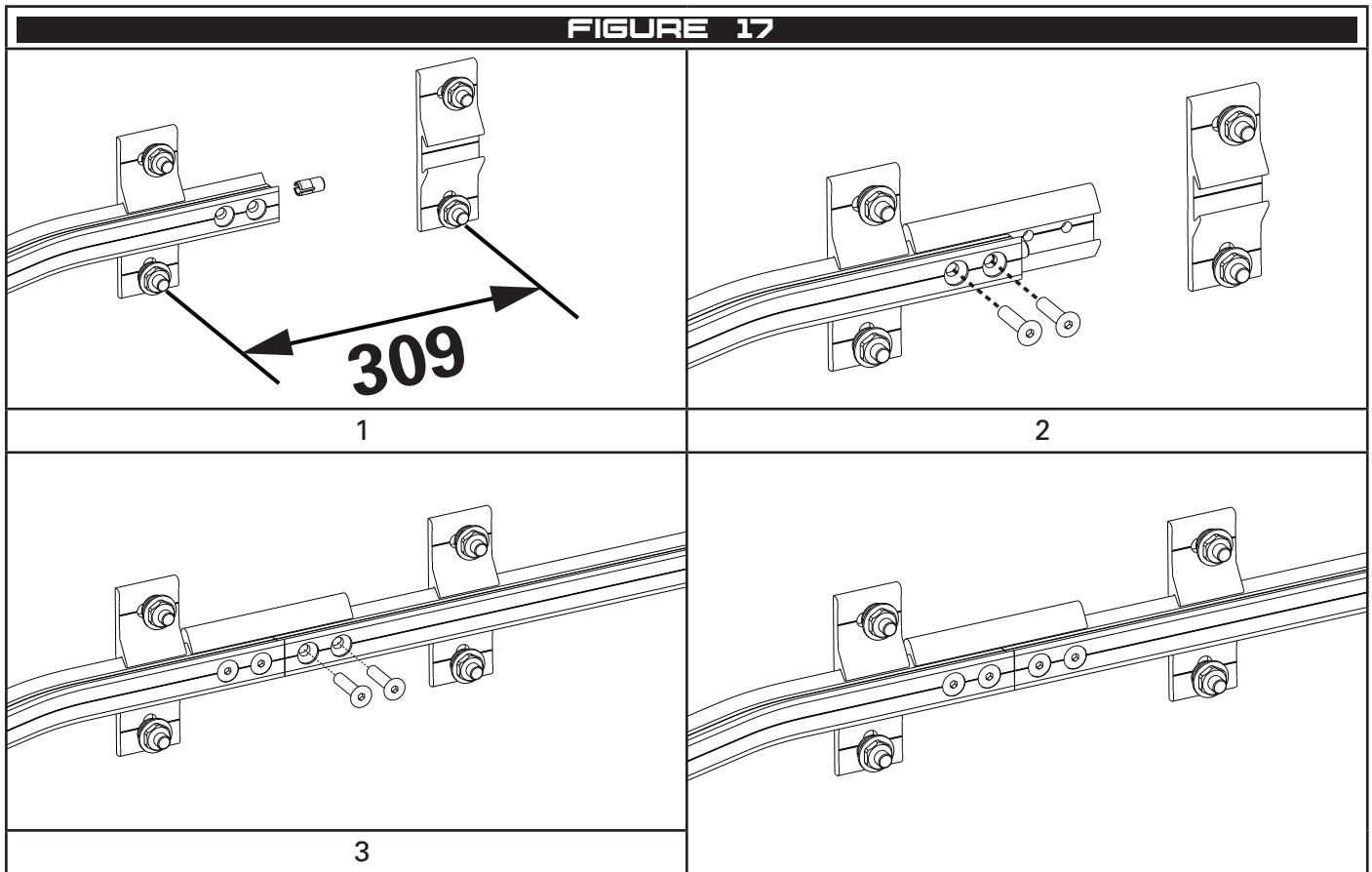

4.7 Intermediate Join

✓ Intermediate Joins act as both intermediate brackets and joins. They do not require intermediate brackets either side as per Section 4.6.

⚠ **Intermediate joins prevent thermal expansion and can lead to rail buckling.**

- 1 Install the bracket as per section 4.4.
- 2 Fix the first section of rail to one side of the bracket with 2 rail screws.
- 3 Install the dowel (slip end first) with a rubber mallet.
- 4 Fix the second piece of rail with 2 rail screws.

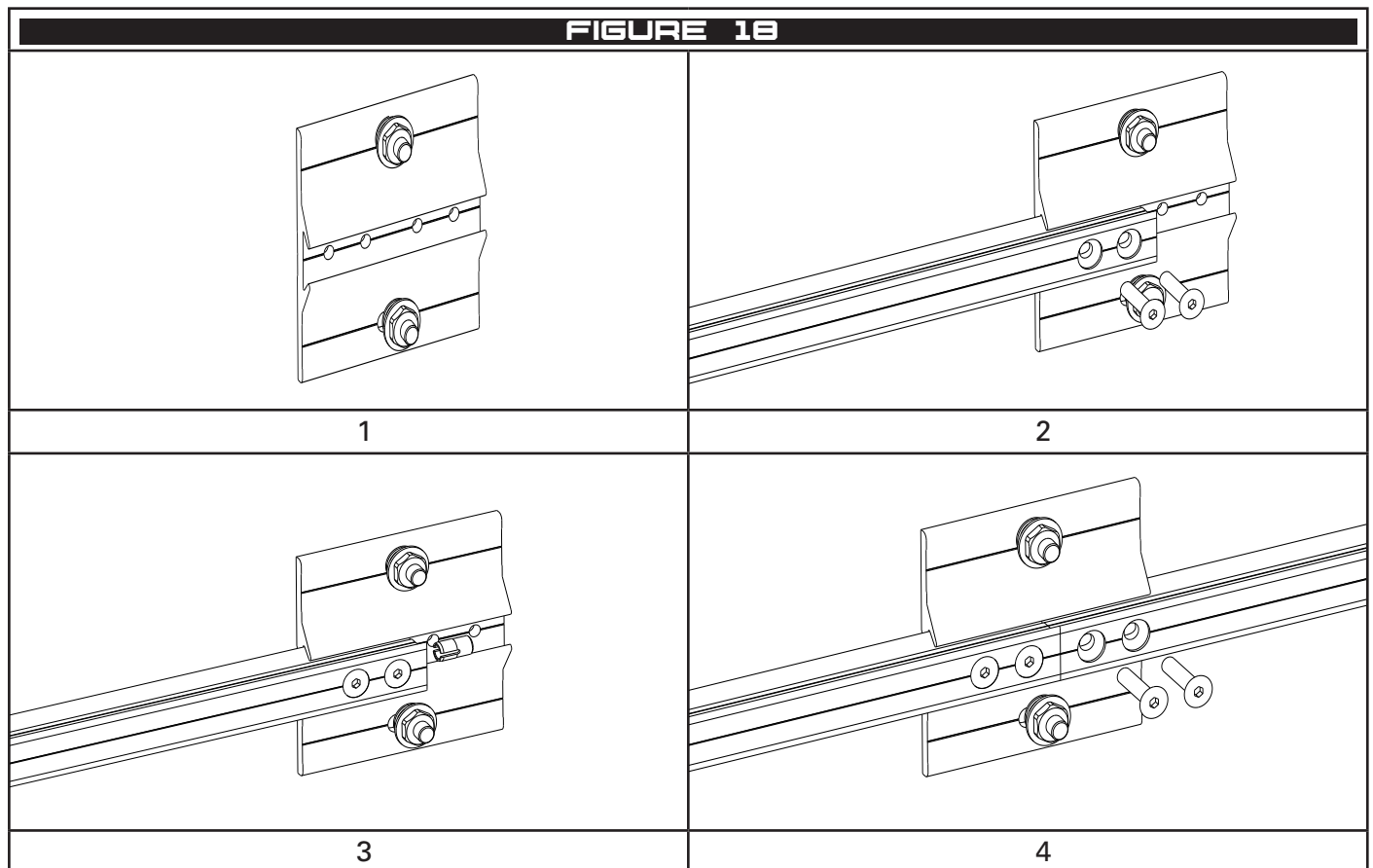

4.8 Shuttle Stop

- 1 Drill a 10.5-11mm hole in the top surface of the rail over the top of the end bracket.
- 2 Slide the shuttle stop on the rail and tighten the screw through the hole

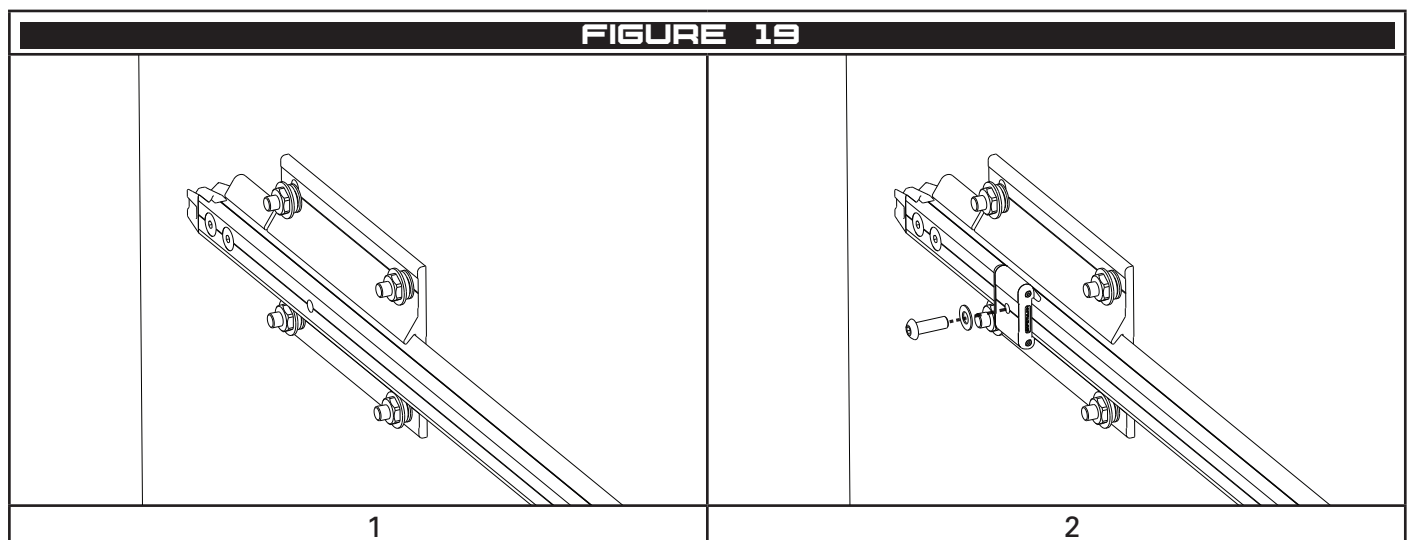

4.9 Gate - Mid Span

- 1 Install two intermediate brackets no further than 600mm apart. Insert the system rail with a rail dowel through the first intermediate.
- 2 Install the join on the rail and fasten with two rail screws.
- 3 Complete the installation by connecting the other end of the rail system, through the second intermediate, with a rail dowel and two rail screws.

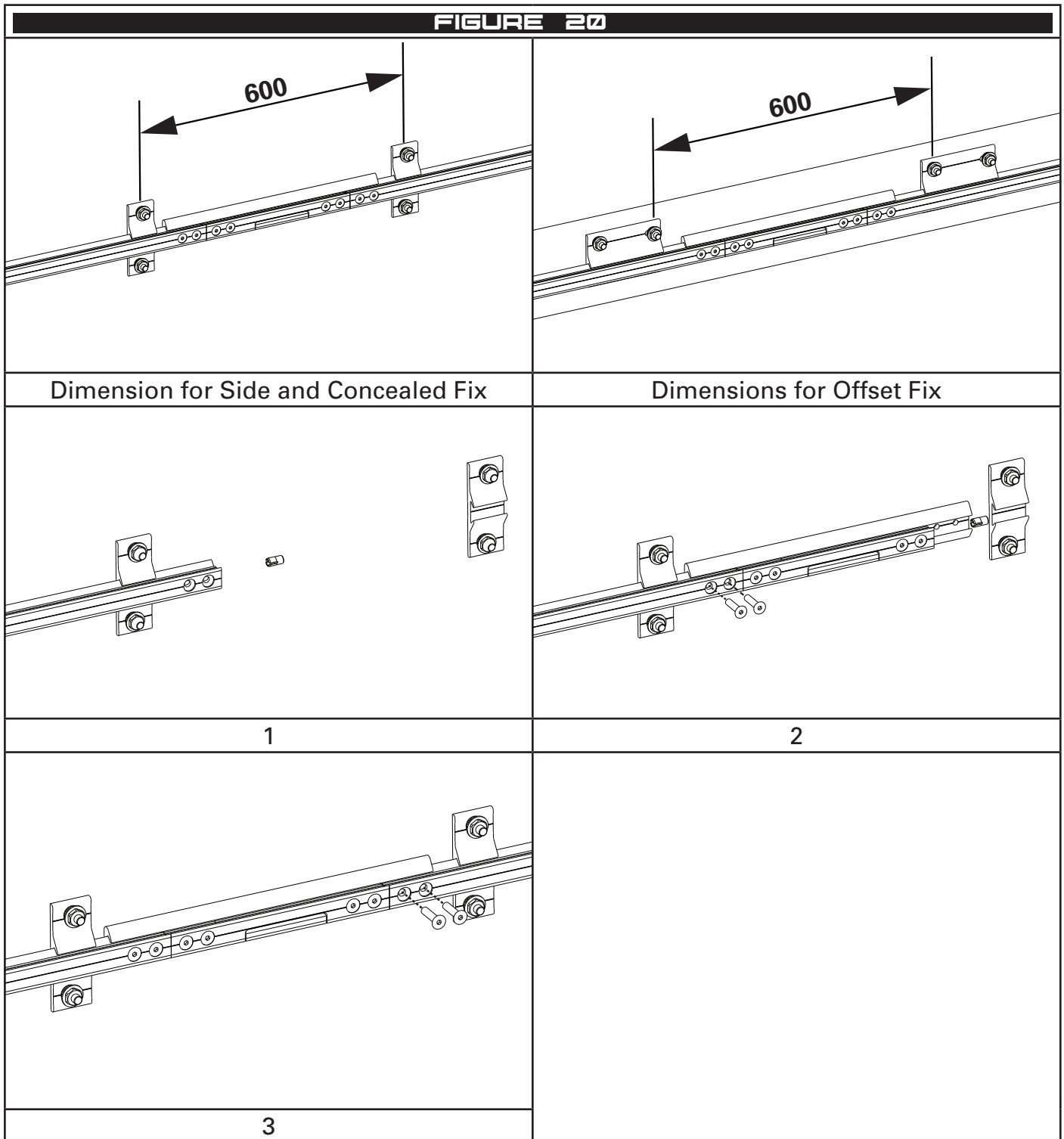

4.10 Gate - End

- 1 Install the end bracket of the system and insert the rail through the bracket with a rail dowel.
- 2 Install the gate and fasten with two rail screws.

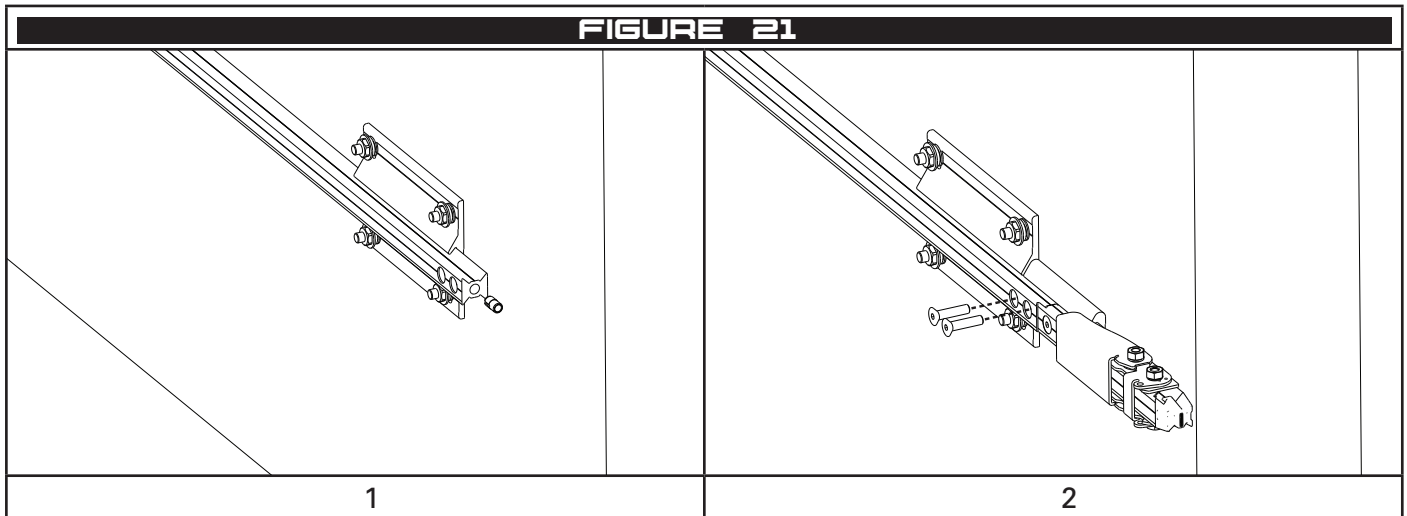

4.11 Tuff-Post

The Concealed Fix system may be installed on SafetyLink Tuff-Posts. To do so, the threaded adaptor ADAPTER M12-M16 is required. Refer to the Tuff-Post instruction handbook for installation methods and limitations of use.

⚠ Abseil systems shall not be installed on the 900mm Round Tuff-Post.

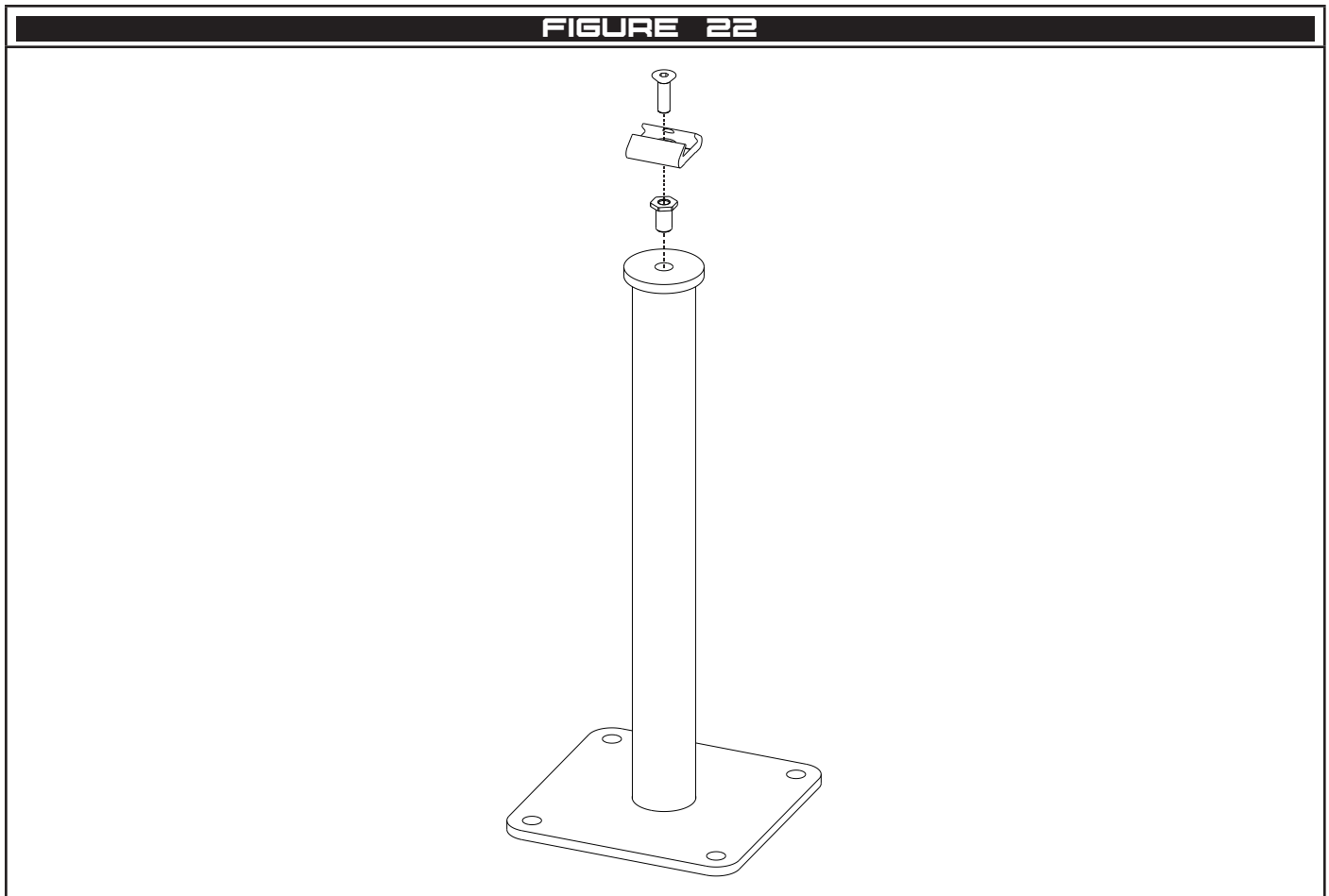

4.12 BeamLink

The Concealed Fix system may be installed on SafetyLink's BeamLink. Refer to the BeamLink instruction handbook for installation methods and limitations of use.

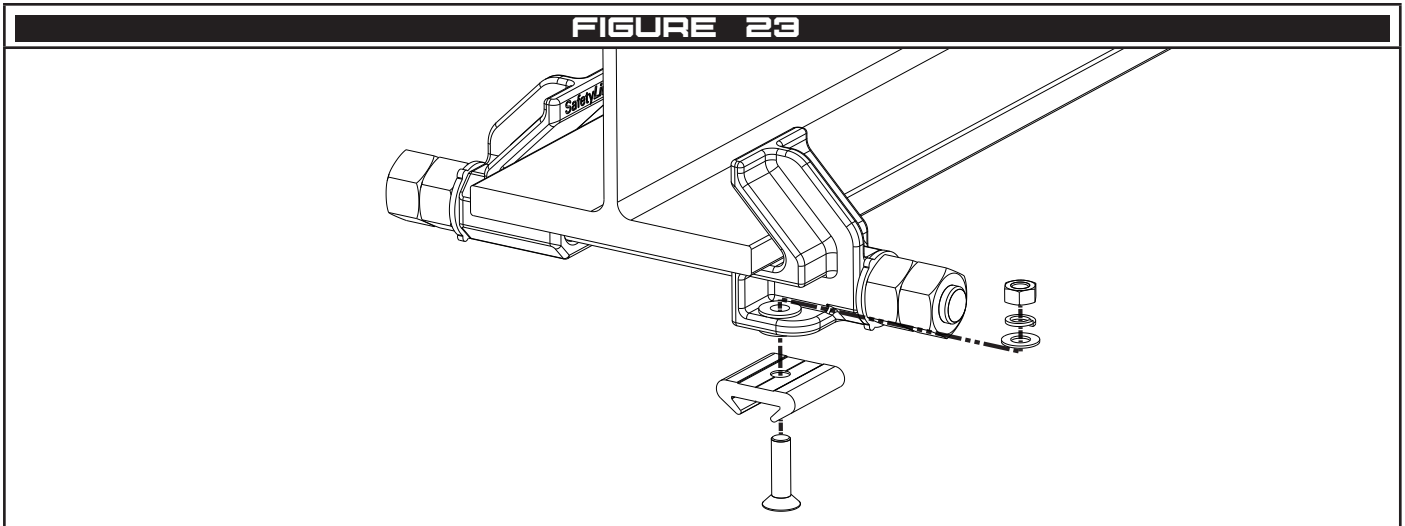

4.13 SteelLink

All the X-Rail systems may be installed on SafetyLink's SteelLink. Refer to the SteelLink instruction handbook for installation methods and limitations of use.

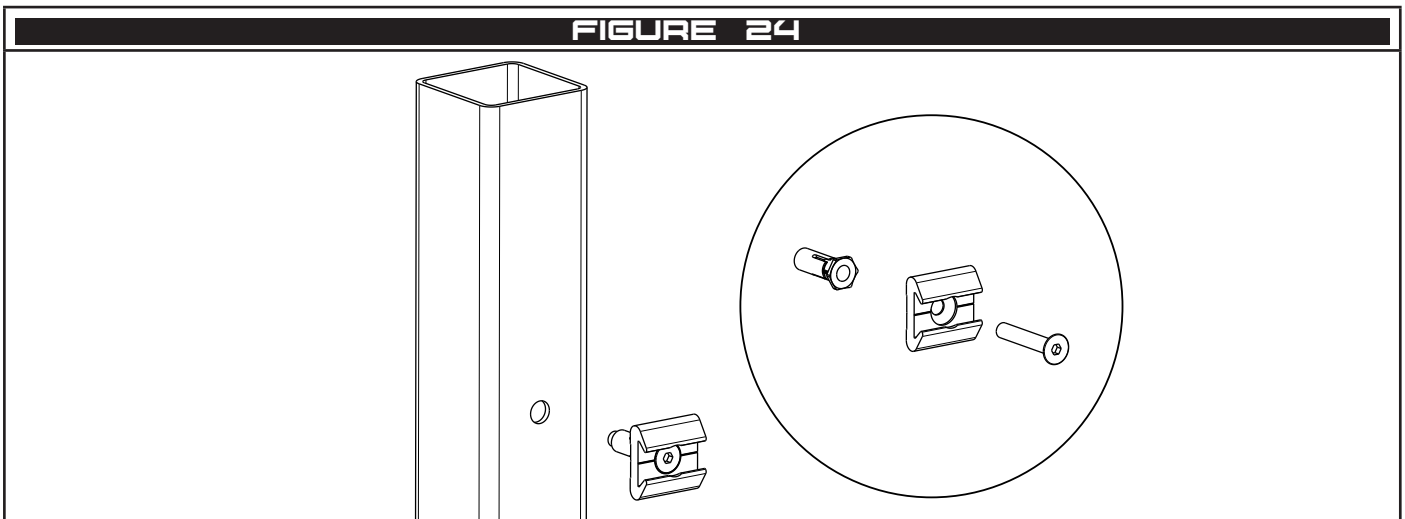

4.14 Tuff-Bracket

The Concealed Fix system may be installed on SafetyLink's Tuff-Bracket with adaptor FROGLINE BUSH M16-M12. Refer to the Tuff-Bracket instruction handbook for installation methods and limitations of use.

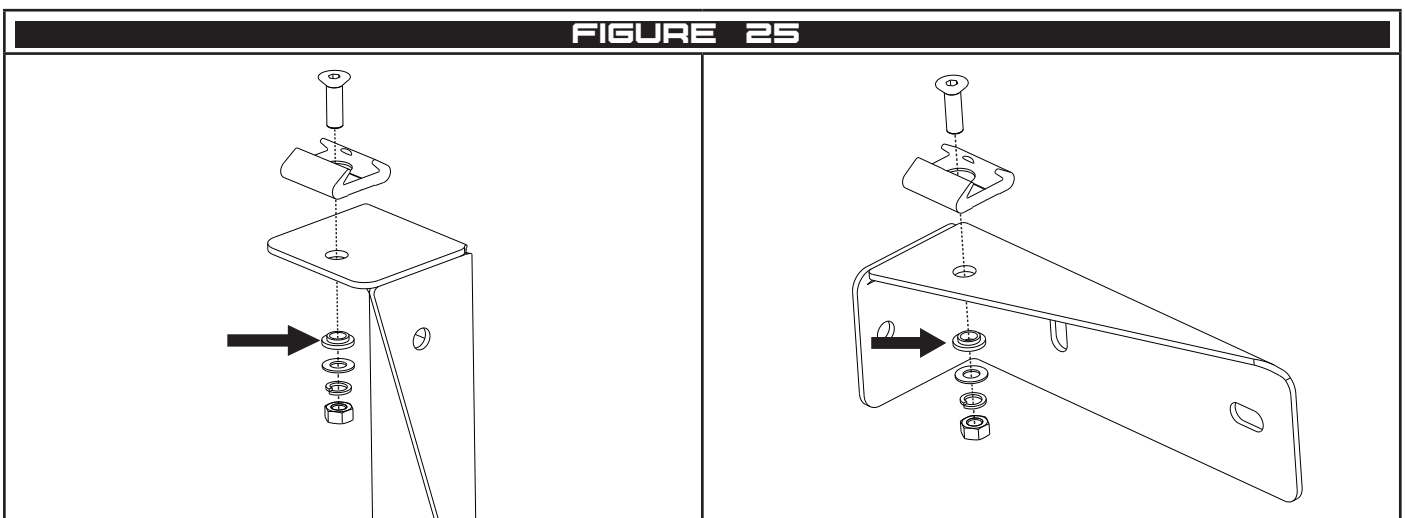

4.15 Expansion Joins

- ✓ Only suitable for installation with Side Fix and Concealed Fix systems.

A straight 10m length of X-Rail Rigid Anchor Line will expand or contract 1mm for every 10°C change in temperature. An expansion join is only required on sections of rail that are fixed at both ends by corners. Rail sections with an end gate or system termination will allow for expansion and contraction.

When installing the system, the gap between the two rail sections in the expansion assembly should be set according to the current temperature relative to the maximum and minimum temperature experienced in the location.

FIGURE 26	
TEMPERATURE RANGE	SPACER
100%-90% of the maximum	No spacer
90%-60% of the maximum	5mm Spacer
60-10% of the maximum	9mm Spacer
10% of the maximum - to minimum	15mm Spacer

- 1 Install the two end intermediate brackets. Insert the rail into the first intermediate bracket and install the rail dowel, split end first.
- 2 Onto the rail, install a join block with two rail screws.
- 3 Slide the remaining two intermediate brackets on the expansion section and position on the studs or bolting locations. Attach one end of the expansion section to the join block installed in step 2 with two rail screws.

⚠ Ensure the appropriate spacer is in the expansion section during installation.

- 4 Complete the assembly by joining the other end of the expansion section with a join block, rail dowel and four rail screws.

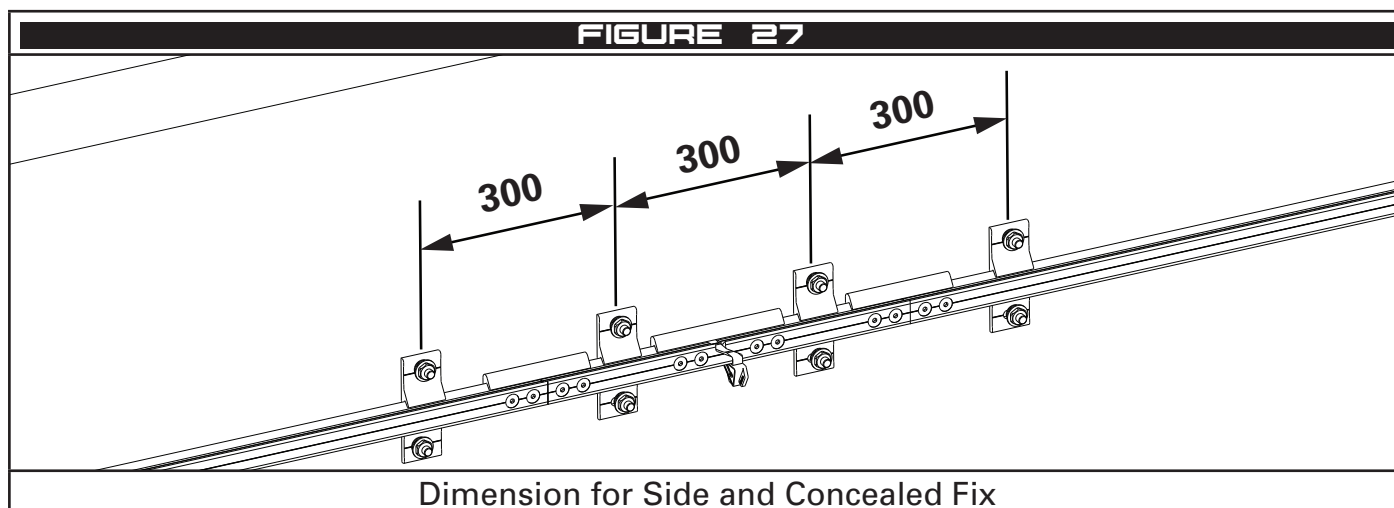

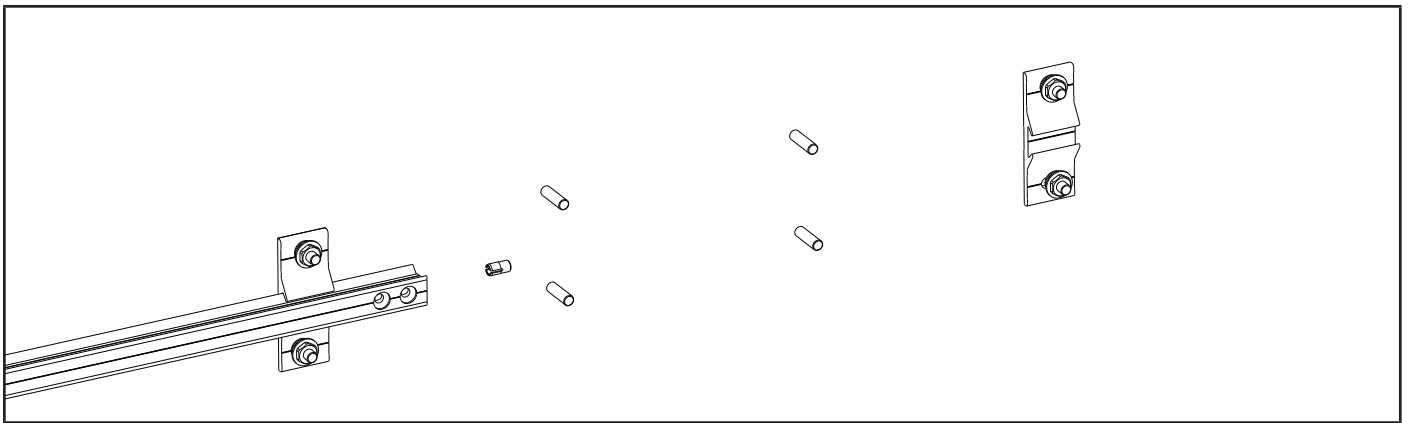

1

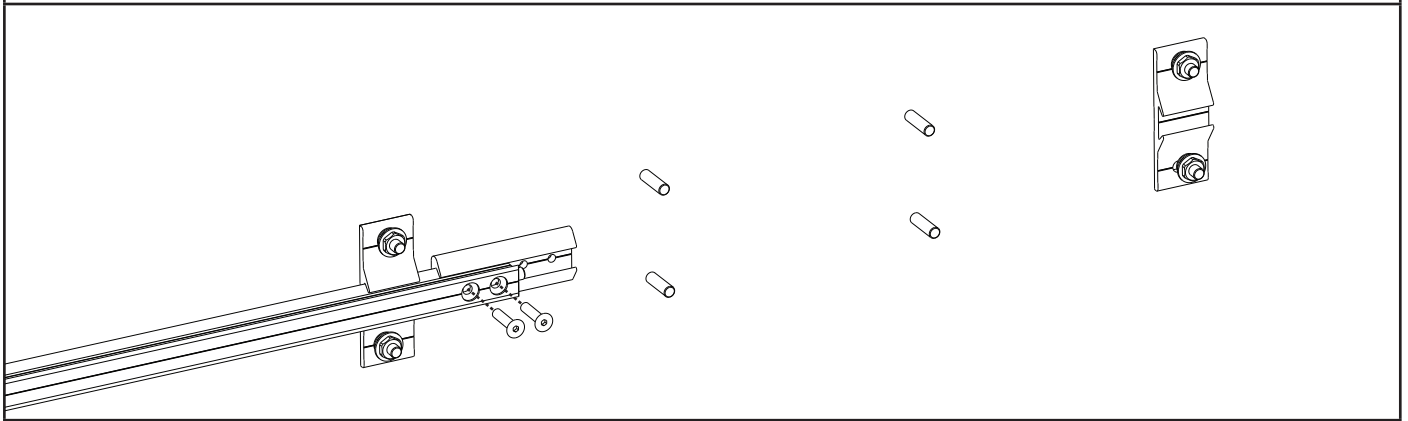

2

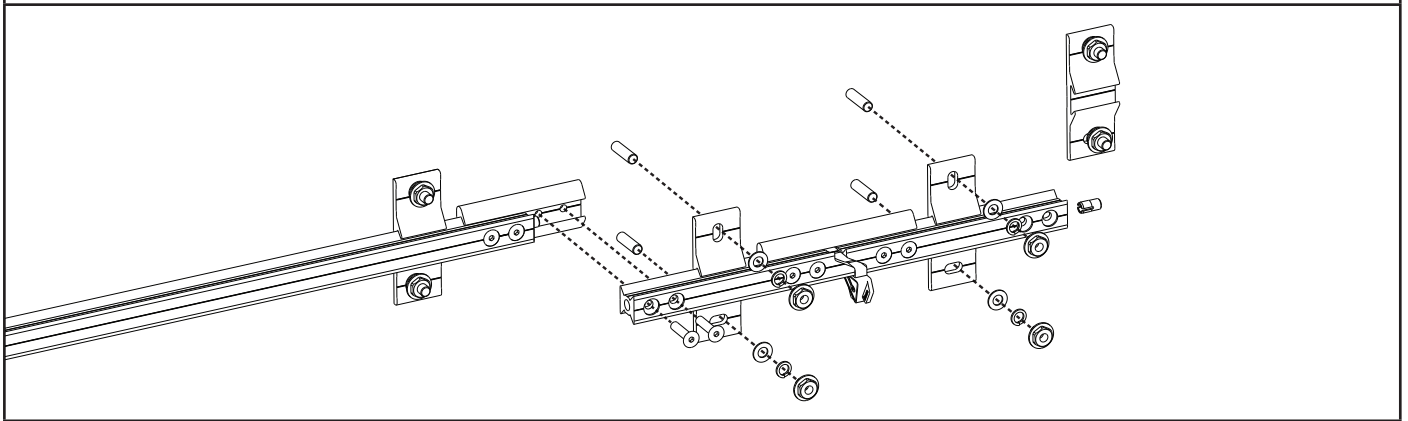

3

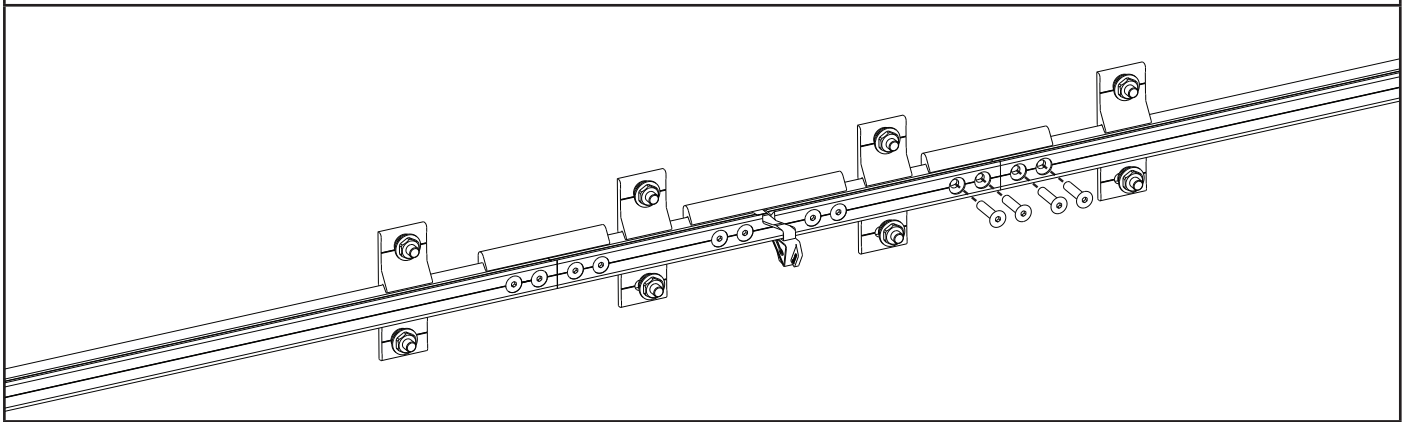

4

4.16 External Corner Assemblies (Wall Mounted)

4.16.1 Side Fix

- 1 Install the four external brackets.
- 2 On one side of the wall, install an intermediate bracket onto the closest external bracket. Install a second intermediate bracket on one side the corner rail and slide the other end of the corner rail into the first intermediate bracket.
- 3 On each side of the corner rail, install the jog rails by sliding an intermediate bracket on each end and fastening to the corner rail with a rail dowel, join plate and four join screws.
- 4 Complete the installation by joining the corner to the rest of the system with a rail dowel, join block and four rail screws.

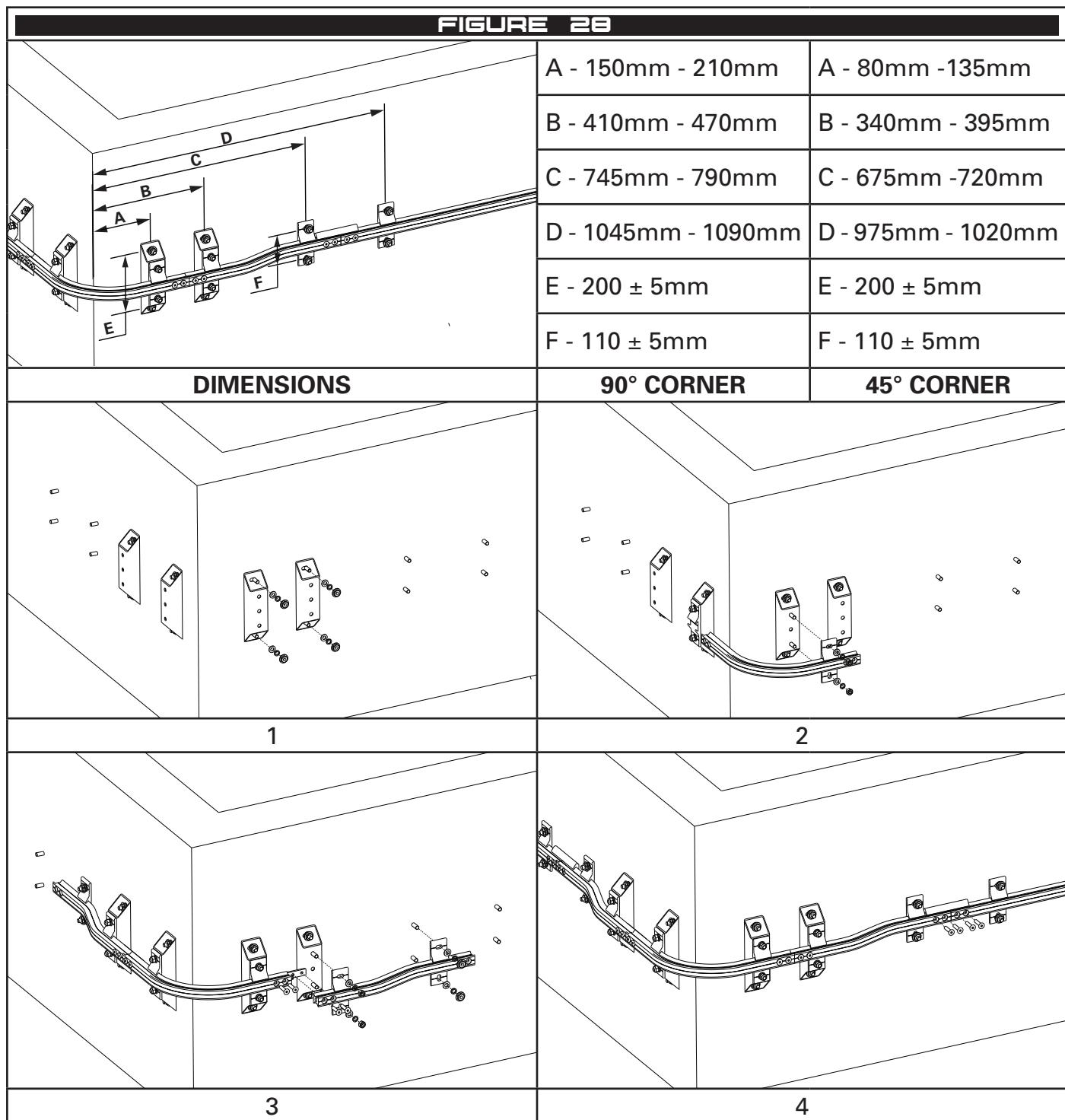

4.16.2 Concealed Fix (Parallel)

- 1 Install the four external brackets.
- 2 On one side of the wall, install an intermediate bracket onto the closest external bracket. Install a second intermediate bracket on one side the corner rail and slide the other end of the corner rail into the first intermediate bracket.
- 3 On each side of the corner rail, install the jog rails by sliding an intermediate bracket on each end and fastening to the corner rail with a rail dowel, join plate and four join screws.
- 4 Complete the installation by joining the corner to the rest of the system with a rail dowel, join block and four rail screws.

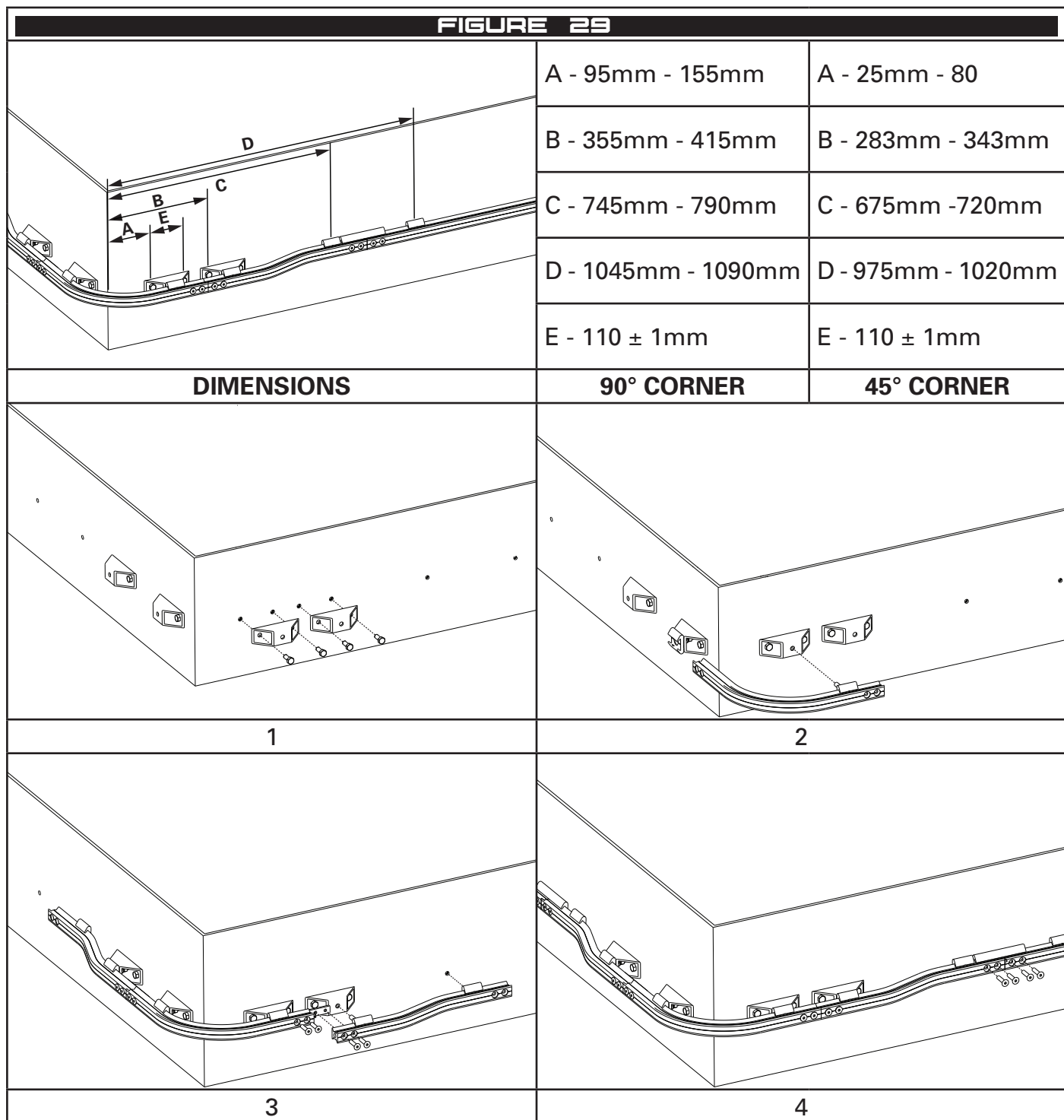

4.16.3 Concealed Fix (Perpendicular)

- 1 Install the four external brackets.
- 2 On one side of the wall, install an intermediate bracket onto the closest external bracket. Install a second intermediate bracket on one side the corner rail and slide the other end of the corner rail into the first intermediate bracket.
- 3 On each side of the corner rail, install the jog rails by sliding an intermediate bracket on each end and fastening to the corner rail with a rail dowel, join plate and four join screws.
- 4 Complete the installation by joining the corner to the rest of the system with a rail dowel, join block and four rail screws.

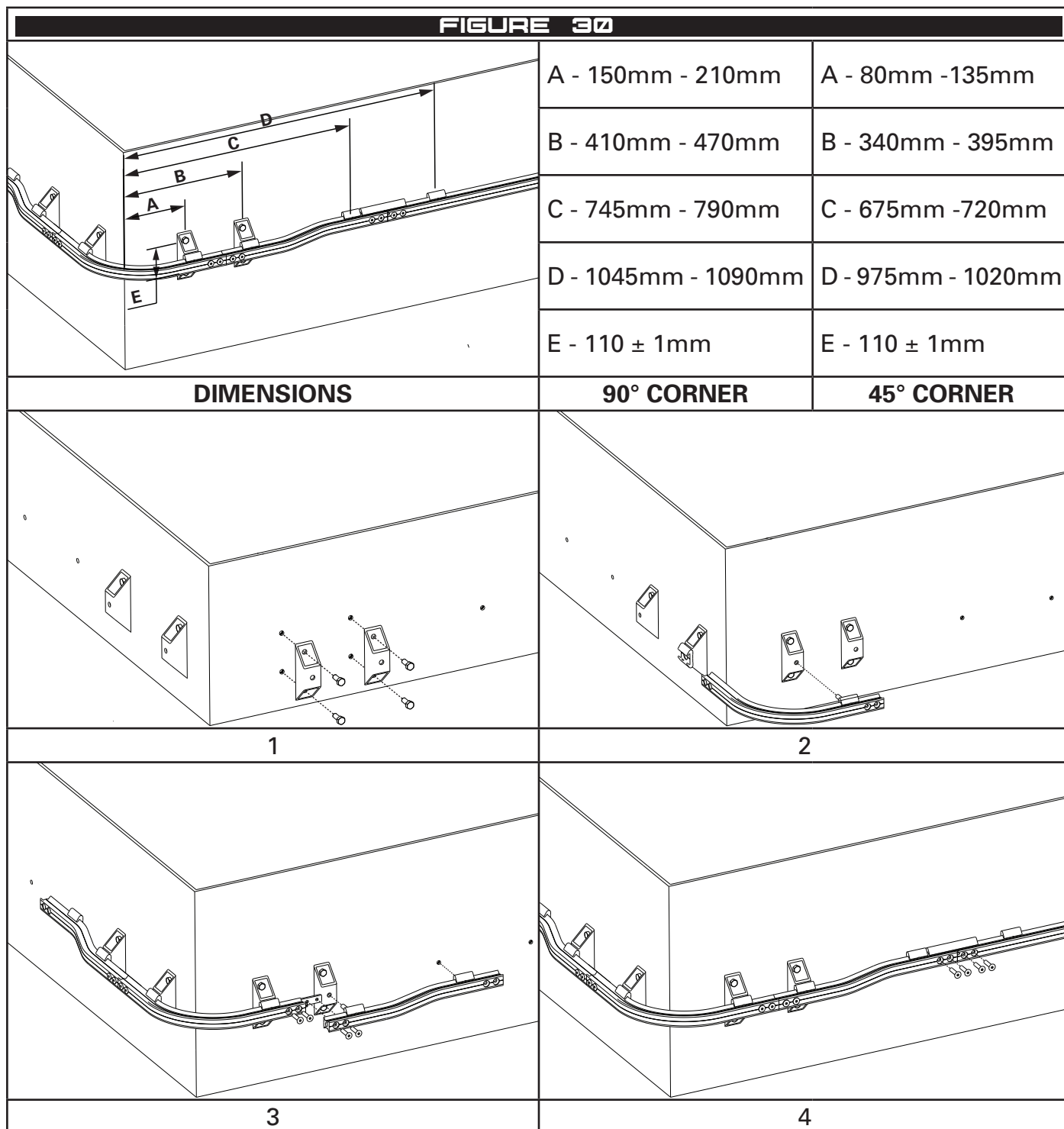

4.16.4 Concealed Fix (no jogs)

- 1 On one side of the wall, install an intermediate bracket. Install a second intermediate bracket on one side of the corner rail and slide the other end of the corner rail into the first intermediate bracket.
- 2 Complete the installation by joining the corner to the rest of the system with a rail dowel, join block and four rail screws.

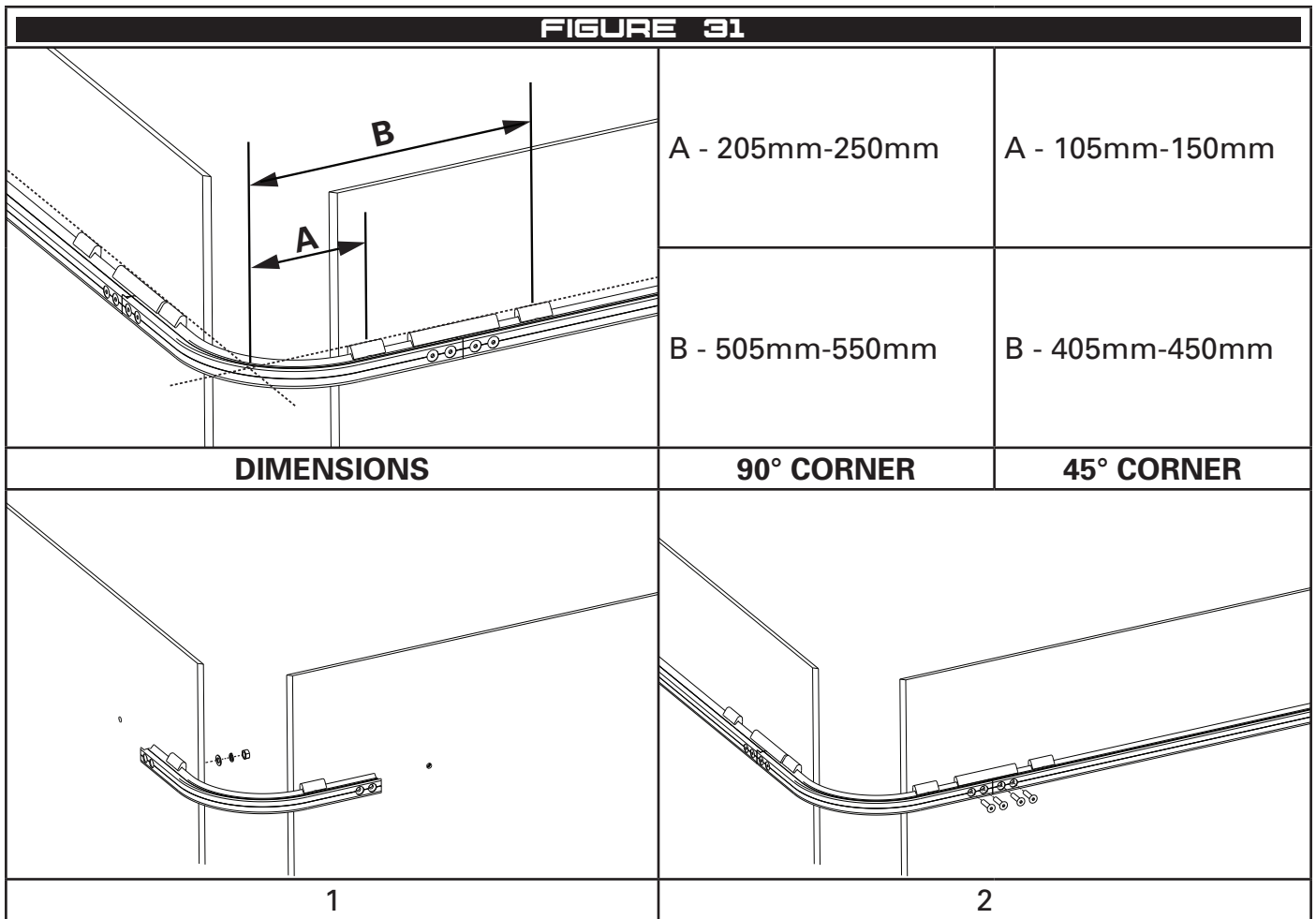

4.16.5 Offset Fix

- 1 Install the two external brackets.
- 2 On one side of the wall, install an intermediate join bracket onto the external bracket. Install a second intermediate join bracket on one side of the corner rail and slide the other end of the corner rail into the first intermediate join bracket. Fix each end of the rail to the brackets with two rail screws.
- 3 On each side of the corner rail, install the jog rails by sliding an intermediate join bracket on one end and fastening to the corner rail with a rail dowel and two join screws.
- 4 Complete the installation by joining the corner to the rest of the system with a rail dowel and two rail screws.

FIGURE 32		
	A - 199mm ±2mm	A - 127mm ±2mm
	B - 843mm ±2mm	B - 771mm ±2mm
	C - 223mm ±1mm	C - 223mm ±1mm
	D - 120mm ±1mm	D - 120mm ±1mm
DIMENSIONS	90° CORNER	45° CORNER
1	2	
3	4	

4.17 Internal Corner Assemblies (Wall Mounted)

4.17.1 Side Fix

- 1 Slide an intermediate bracket onto each end of the corner rail and position the corner to install the intermediate brackets.
- 2 Join the rail system to each end with a rail dowel, join block and four rail screws.

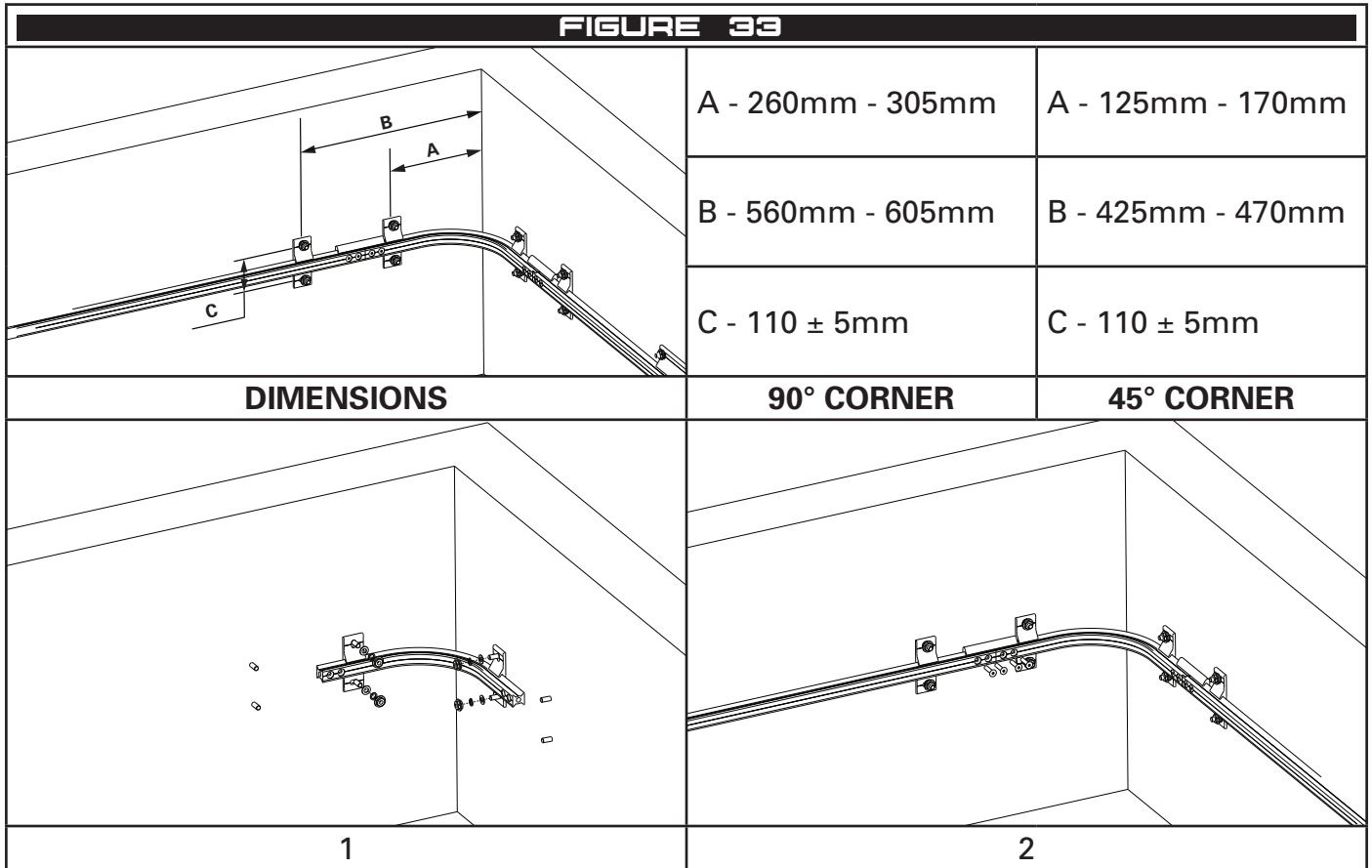

4.17.2 Concealed Fix

- 1 Slide an intermediate bracket onto each end of the corner rail and position the corner to install the intermediate brackets.
- 2 Join the rail system to each end with a rail dowel, join block and four rail screws.

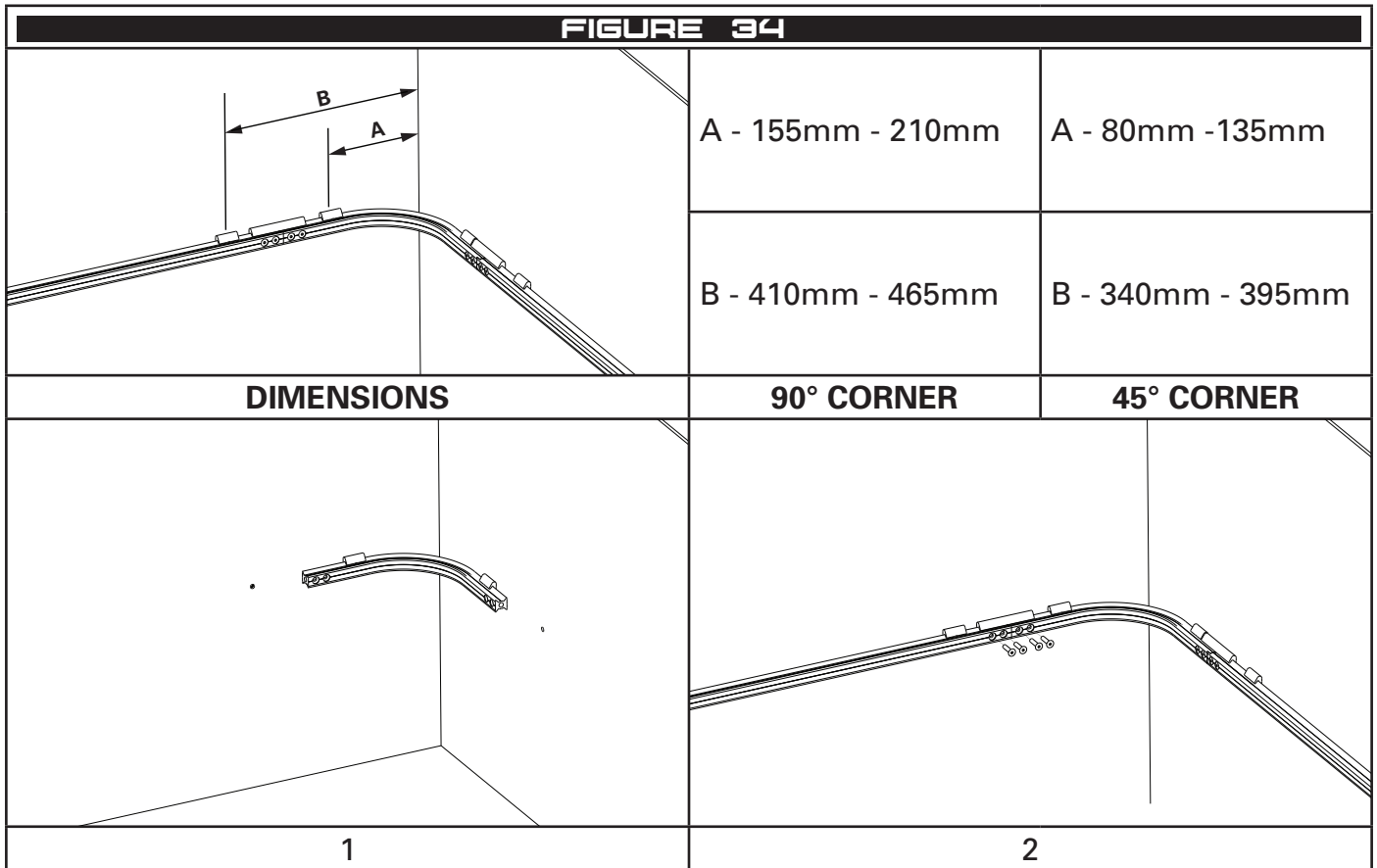

4.17.3 Offset Fix

- 1 Slide an intermediate join bracket onto each end of the corner rail and position the corner to install the intermediate brackets. Fasten each end of the corner rail with two rail screws.
- 2 Join the rail system to each end with a rail dowel and two rail screws.

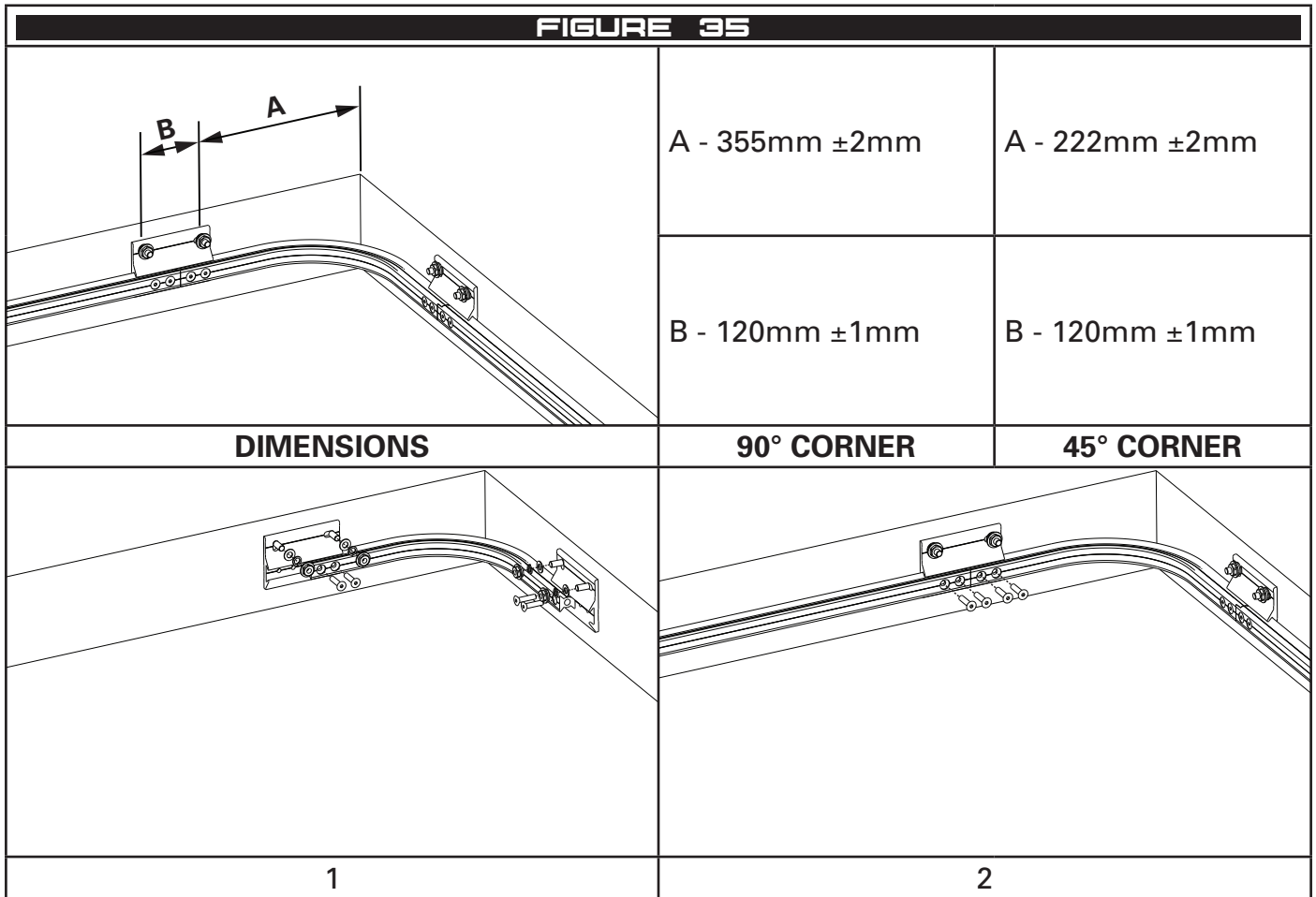

4.18 Corner Assemblies (Floor or Overhead Mounted)

4.18.1 Side Fix

- 1 Slide an intermediate bracket onto each end of the corner rail and position the corner to install the intermediate brackets.
- 2 Join the rail system to each end with a rail dowel, join block and four rail screws.

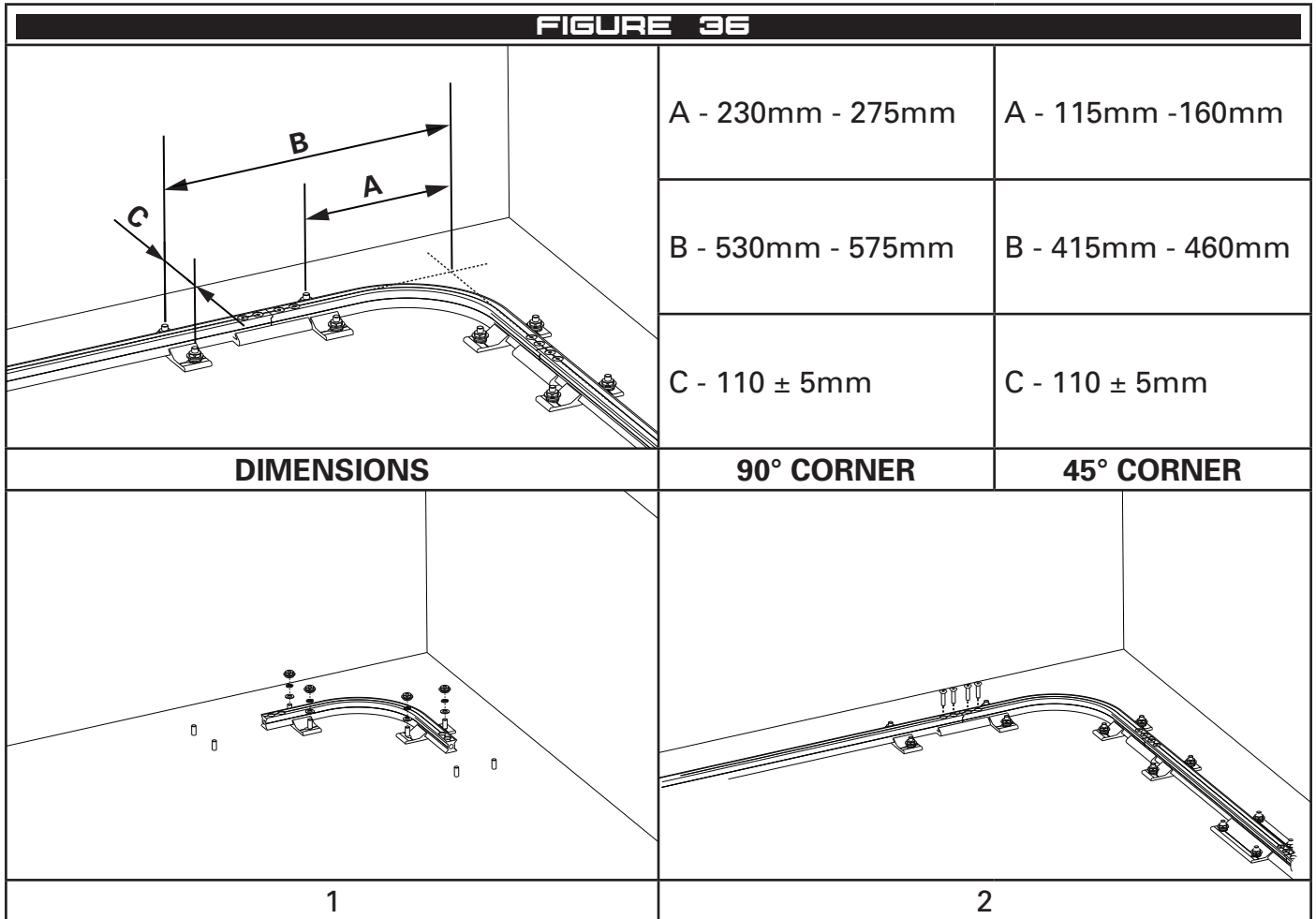

4.18.2 Concealed Fix

- 1 Slide an intermediate bracket onto each end of the corner rail and position the corner to install the intermediate brackets.
- 2 Join the rail system to each end with a rail dowel, join block and four rail screws.

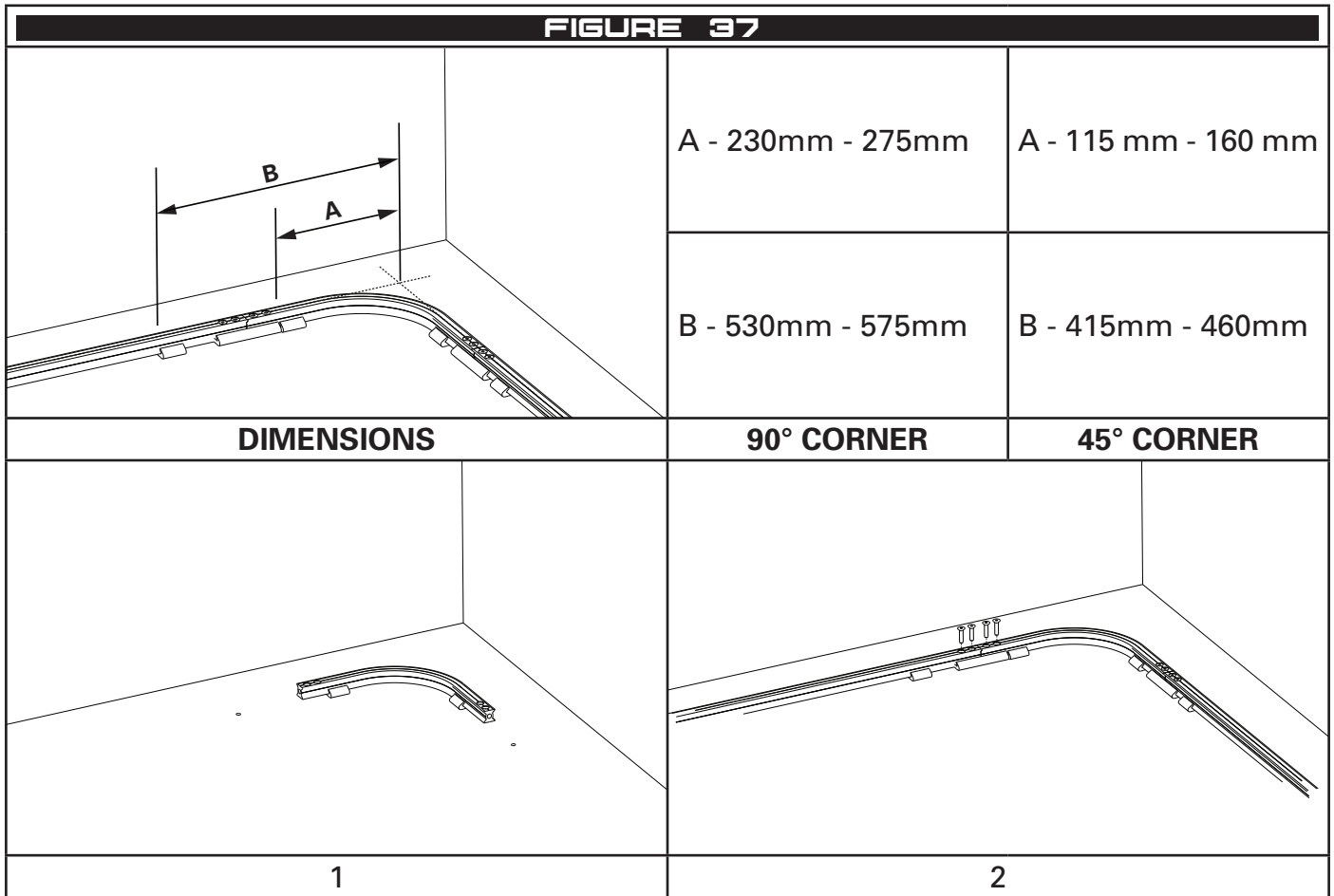

4.18.3 Offset Fix (Floor Only)

- 1 Slide an intermediate join bracket onto each end of the corner rail and position the corner to install the intermediate brackets. Fasten each end of the corner rail with two rail screws.
- 2 Join the rail system to each end with a rail dowel and two rail screws.

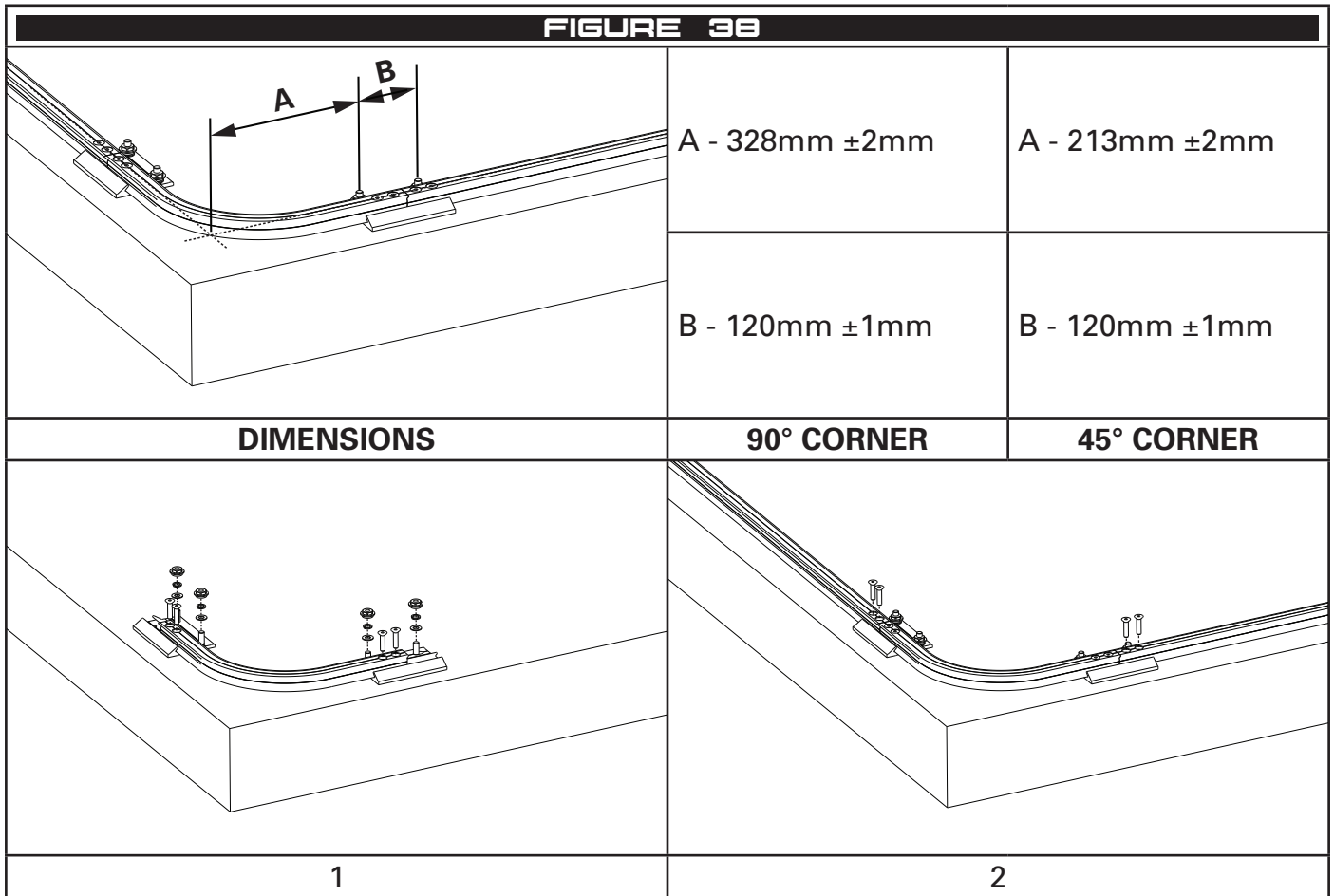

4.19 X-Rail to X-Rail Ultra Join

Using the XRAIL-U-XTX join, X-Rail and X-Rail Ultra systems can be joined to allow shuttles to pass between the 2 system.

- ⚠ **All sections of both the X-Rail and X-Rail Ultra installation manuals shall be followed.**
- ⚠ **The installation of each system shall follow an installation manual containing this clause for joining these system together.**

4.19.1 X-Rail Ultra End Distance

The distance from the final X-Rail Ultra bracket to the start of the X-Rail system shall not exceed 300mm.

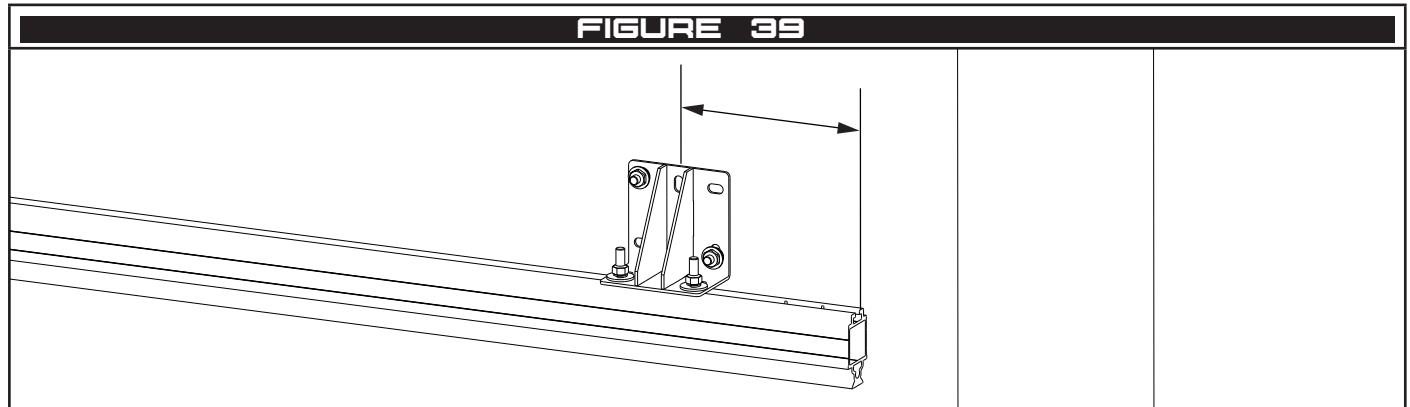

4.19.2 Distance Between Support

The distance between the intermediate brackets of the X-Rail Ultra and X-Rail system shall comply with their respective installation manuals. The distance between the end of the X-Rail Ultra profile and either, the start of an X-Rail Ultra profile, or an X-Rail support bracket shall comply with the requirements of the Concealed Fix X-Rail system.

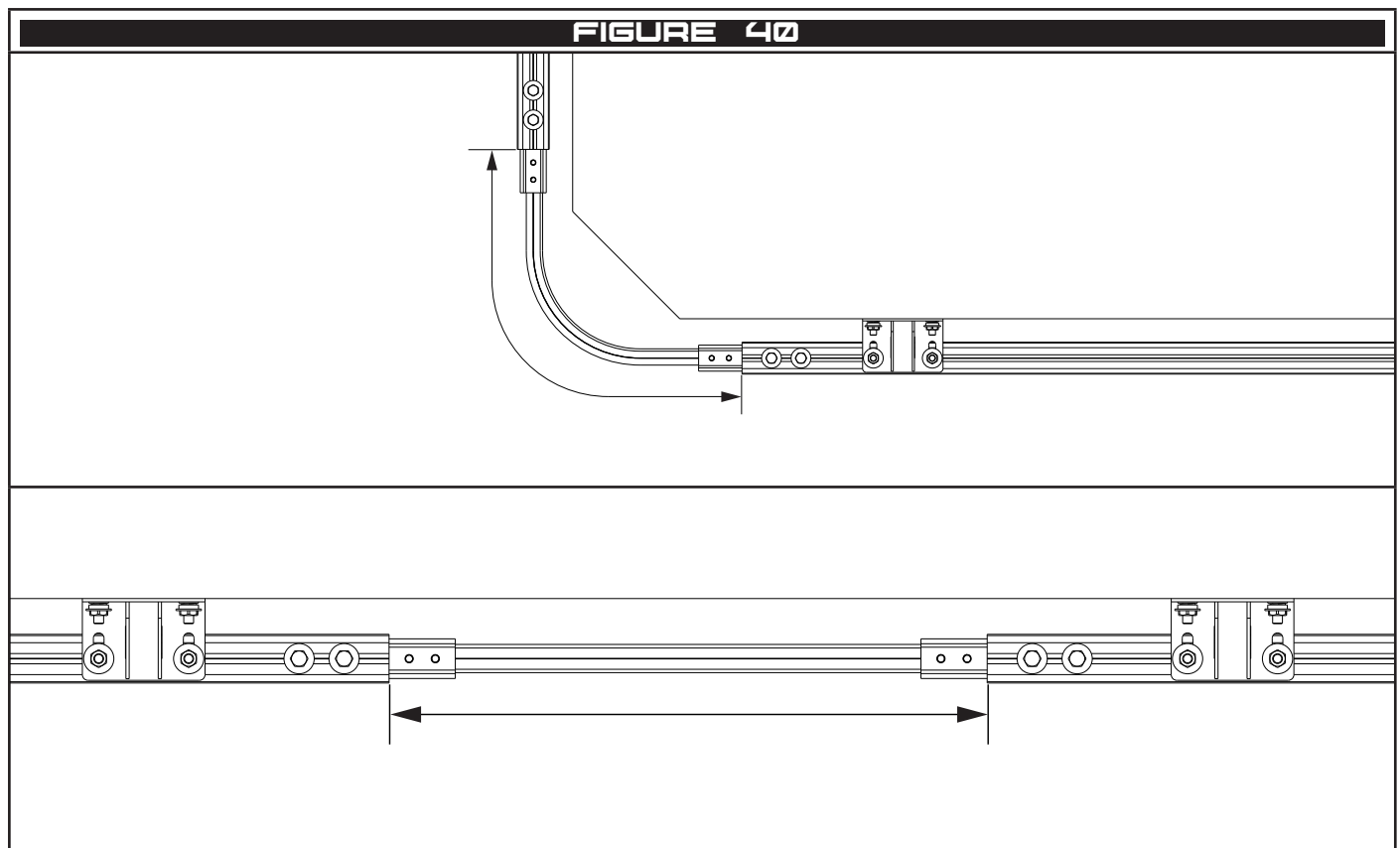

4.19.3 Offset Distance

If the X-Rail profile is bent, the maximum offset distance shall not exceed 195mm when a line is drawn between its extremities. If the rail is on either side of this line, the maximum distance shall be taken in either direction and their sum shall be less than 195mm.

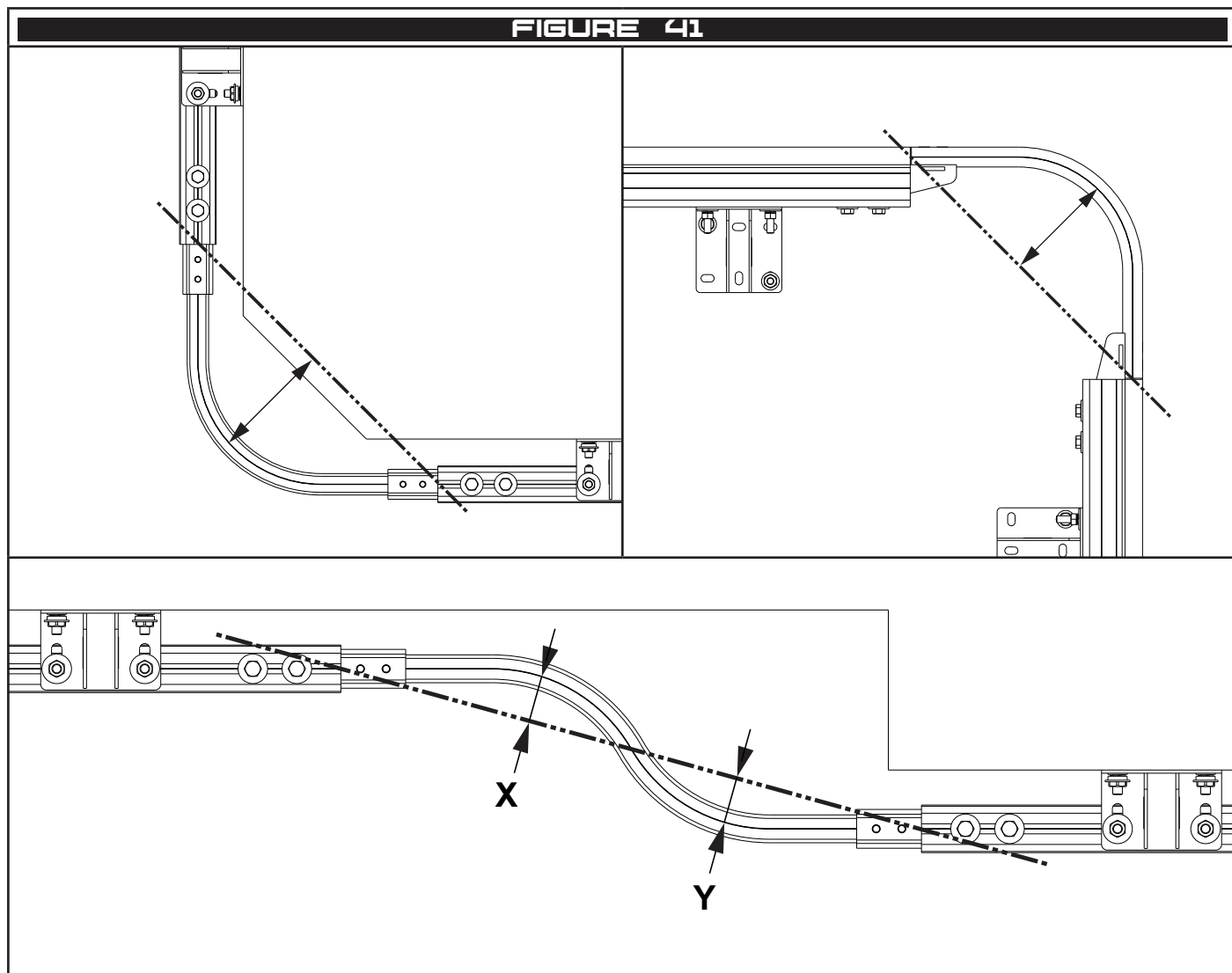

4.19.4 Clearance

There shall be minimum 50mm clearance either side of the centreline of both rails to ensure the shuttle can pass.

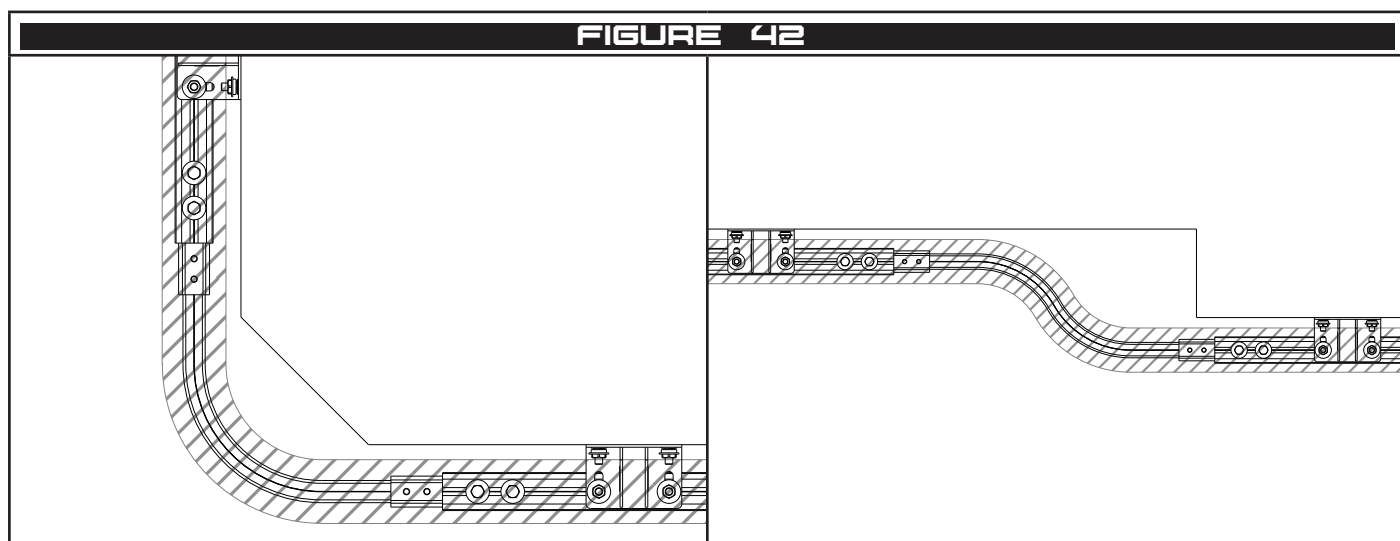

4.19.5 Installation

- 1 Install the final X-Rail Ultra intermediate and prepare the rail but drilling 2 holes as per section 4.13.
- 2 Insert the body of the join in to the X-Rail Ultra profile and fix with 2xM12 rail screws.
- 3 With a rubber mallet install the dowel, slit side first, in to the X-Rail profile. Place the plastic spacer on the dowel and fix the X-Rail to the body of the join with 2xM10 rail screws.
- 4 Repeat the same process to return the system to X-Rail Ultra or continue the system in X-Rail as needed.

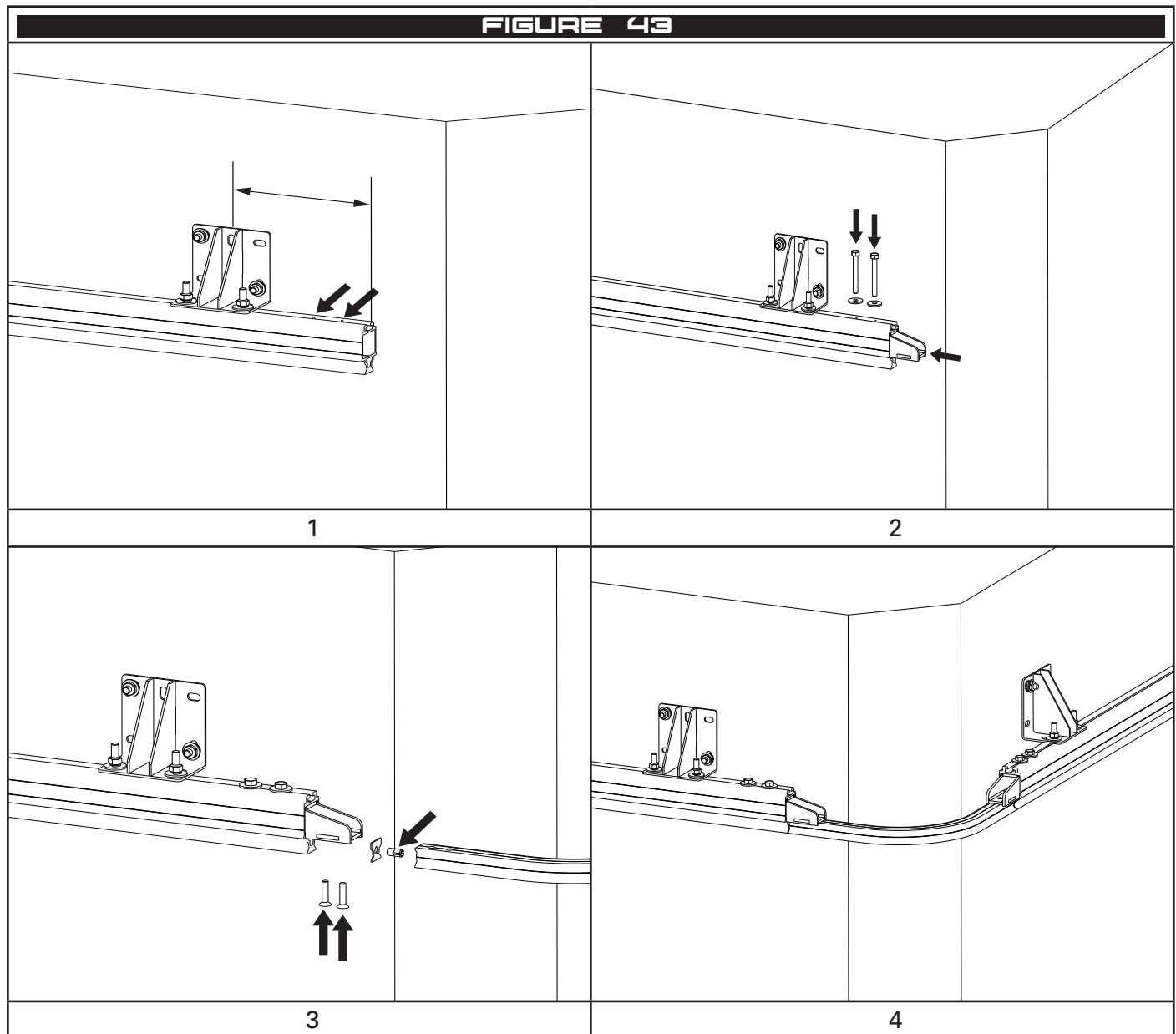

5 Limitations of Use

5.1 Fall Clearance

When planning your fall protection system, it is important to accurately assess all components of your system in order to avoid injury. Figure 44 provides guidance on how to calculate fall clearance. In Figure 44, (D) represents deflection of the anchor (see Figure 5), (E) represents energy absorber deployment and estimated D-ring slide of the harness (Refer the manufacturer's information), (SF) represents the recommended safety factor of 1m, (FC) represents the total allowable fall clearance. For safe use, FC shall always be greater than $D + E + SF$.

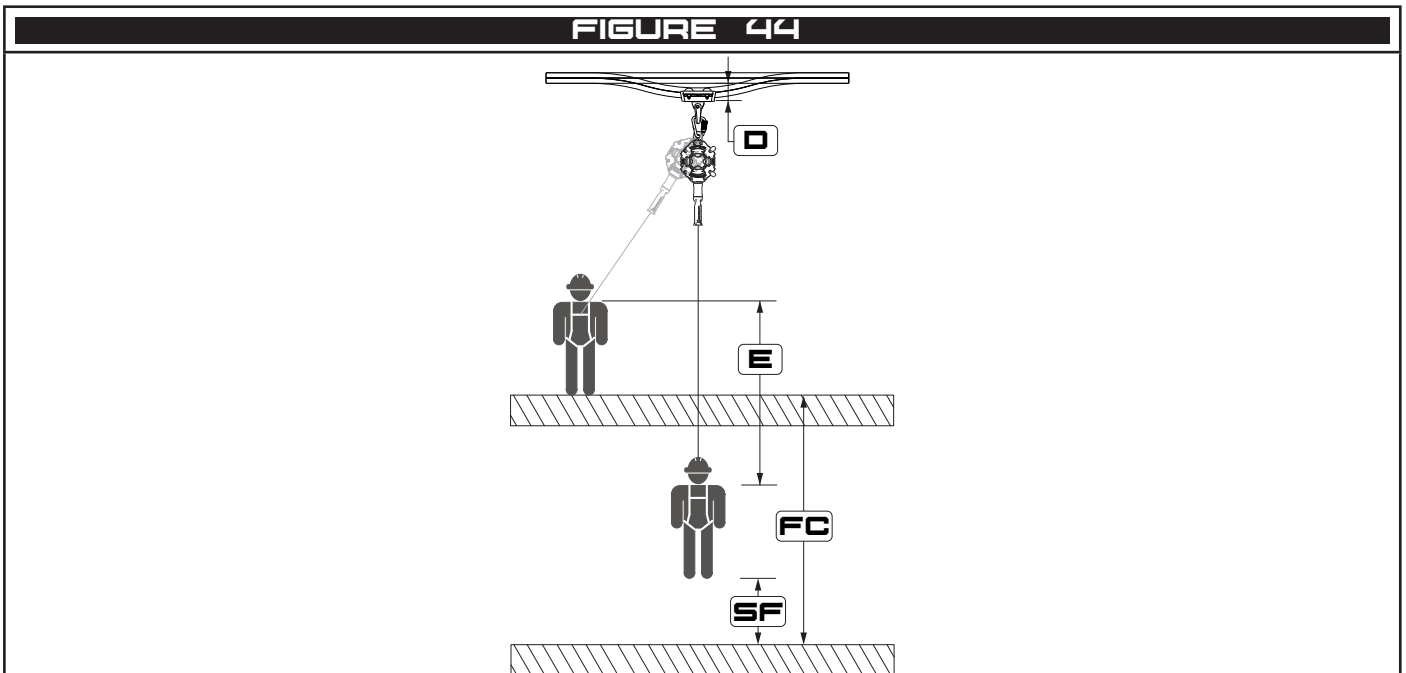

5.2 Swing Fall

Working off centre of a Horizontal Rail System may cause a swing fall. See Figure 45. Fall protection systems shall be setup in such a way to limit swing fall.

⚠ The force of striking an object during a swing fall may result in serious injury or death.

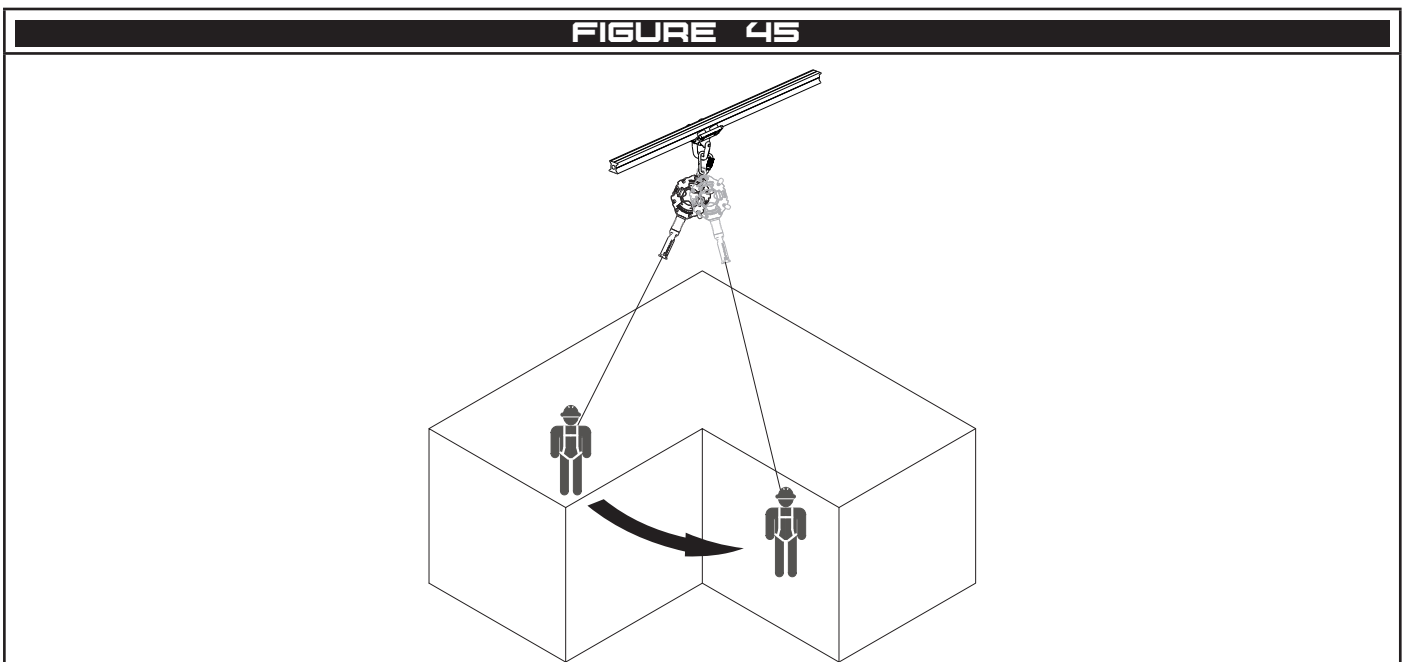

5.3 Area of Use

Working outside of the area of use of a Horizontal Rail System may cause the anchor to malfunction.

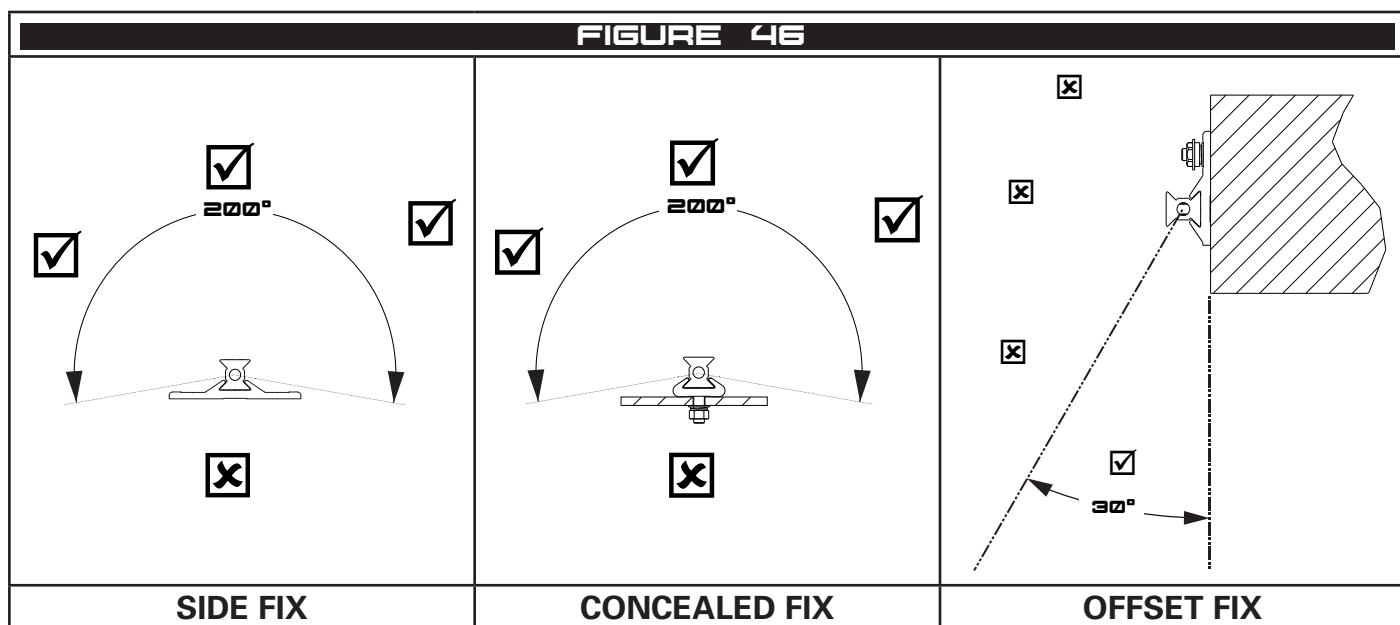

⚠ Always work within the area highlighted in Figure 46.

5.4 Hazards

Use of this equipment in the presence of hazards may cause damage to the equipment and/or result in the function of the equipment being impeded. These hazards include but are not limited to; extreme temperature, sharp edges, chemical reagents, electrical conductivity, abrasion, cutting, climatic exposure and rotating or moving machinery.

5.5 Training

It is essential that all users are trained in the proper inspection, setup and use of this equipment. It's the responsibility of the user to ensure they are trained in the correct use of this equipment and understand the limitations of its use.

⚠ Incorrect use of this equipment may result in serious injury or death.

5.6 Rescue

It is the responsibility of the user of this equipment and their employer to have a suitable rescue plan and the ability to implement it at any time during setup and use of this equipment.

6 Connections

6.1 Making Connections

Only make compatible connections. Always ensure connectors close and lock correctly before use. Below and Figure 47 are examples of unsuitable connections;

- 1 To an anchor or D-ring which has another connector attached.
- 2 In a position that will apply load to the gate mechanism.
- 3 By passing the connection through the attachment.
- 4 Connecting a connector to another connector.
- 5 Around a structure and back to the lifeline.
- 6 To an attachment that will limit the function of the gate.
- 7 To a location that will not load the connector as designed.

6.2 Compatibility of Connections

Connections made to and with this equipment shall be compatible. Connectors shall be compatible shape, size and equivalent rating in order to ensure a compatible connection is made. Incompatible connections may cause loading of the gate mechanism leading to unintentional disengagement. See Figure 48. Connectors shall be compliant with EN362 and auto closing and locking.

⚠ Making incompatible or unsuitable connection may result in unintentional disengagement of the connector resulting in serious injury or death.

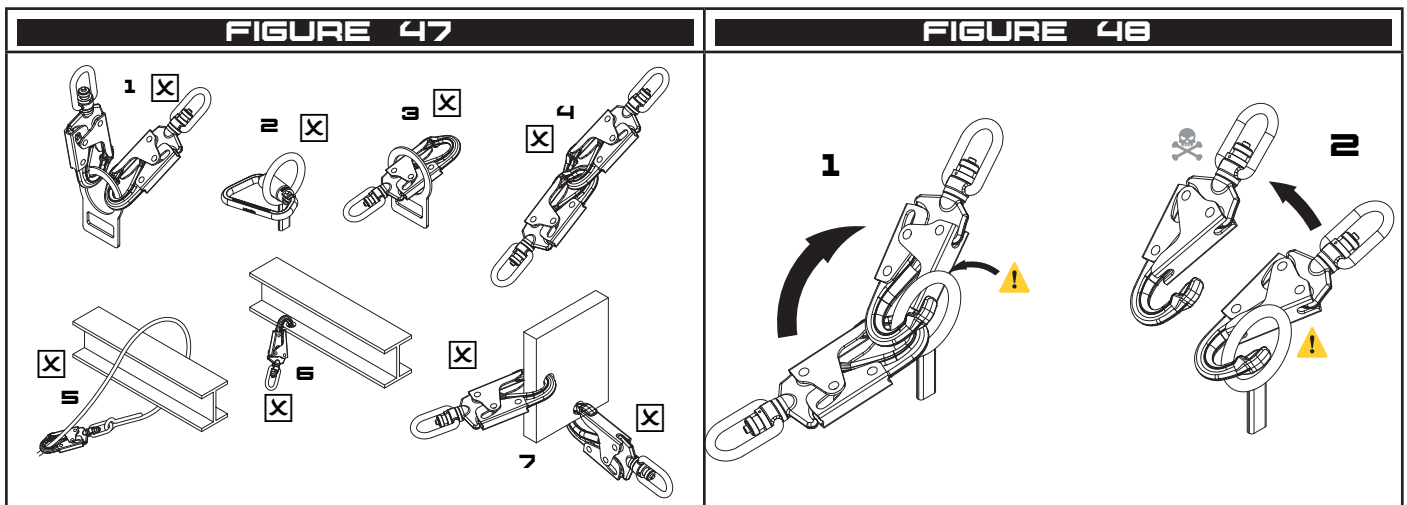

7 Use

7.1 Planning

Before starting work, plan your working at heights and rescue systems by accounting for all hazards present in the work place and allowing for the available fall clearance. Ensure all users are fit, healthy and capable of safely operating this equipment as well as implementing the rescue plan.

⚠ *During use always allow for the required fall clearance, swing fall and hazards present in the work place.*

7.2 X-Rail Gate operation

7.2.1 End Gate

- 1 Unlock the gate by lifting the lock at the rear.
- 2 Open the latch by lifting the latch plate.
- 3 Install or remove the required shuttles.
- 4 Release the latch plate and ensure the latch rotates back and locks.

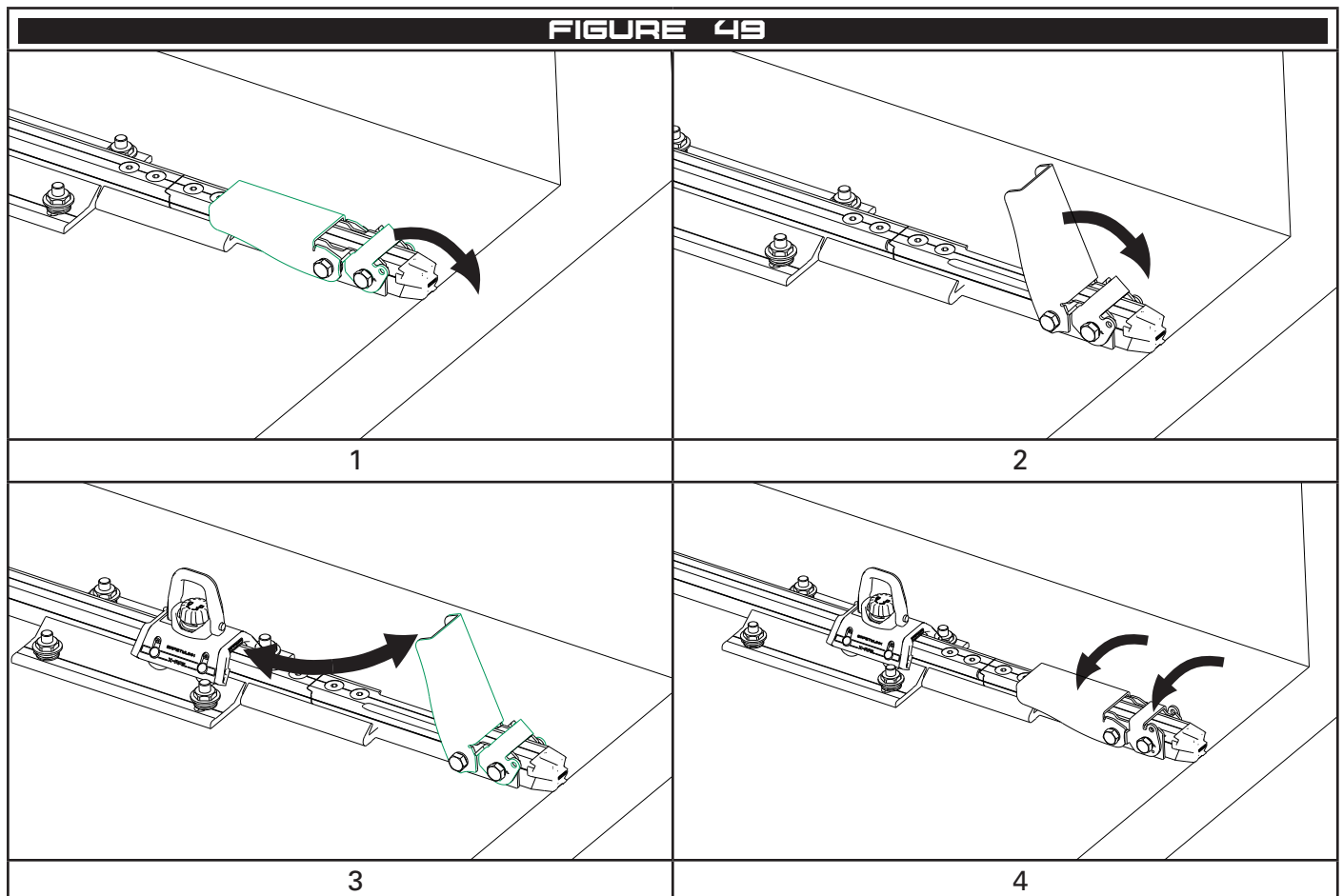

7.2.2 Intermediate Gate

- 1 Unlock the gate by sliding the locking bar to the side
- 2 Open the latch by pressing down on the latch.
- 3 Install or remove the required shuttles.
- 4 Release the latch bar and ensure the latch rotates back and locks.

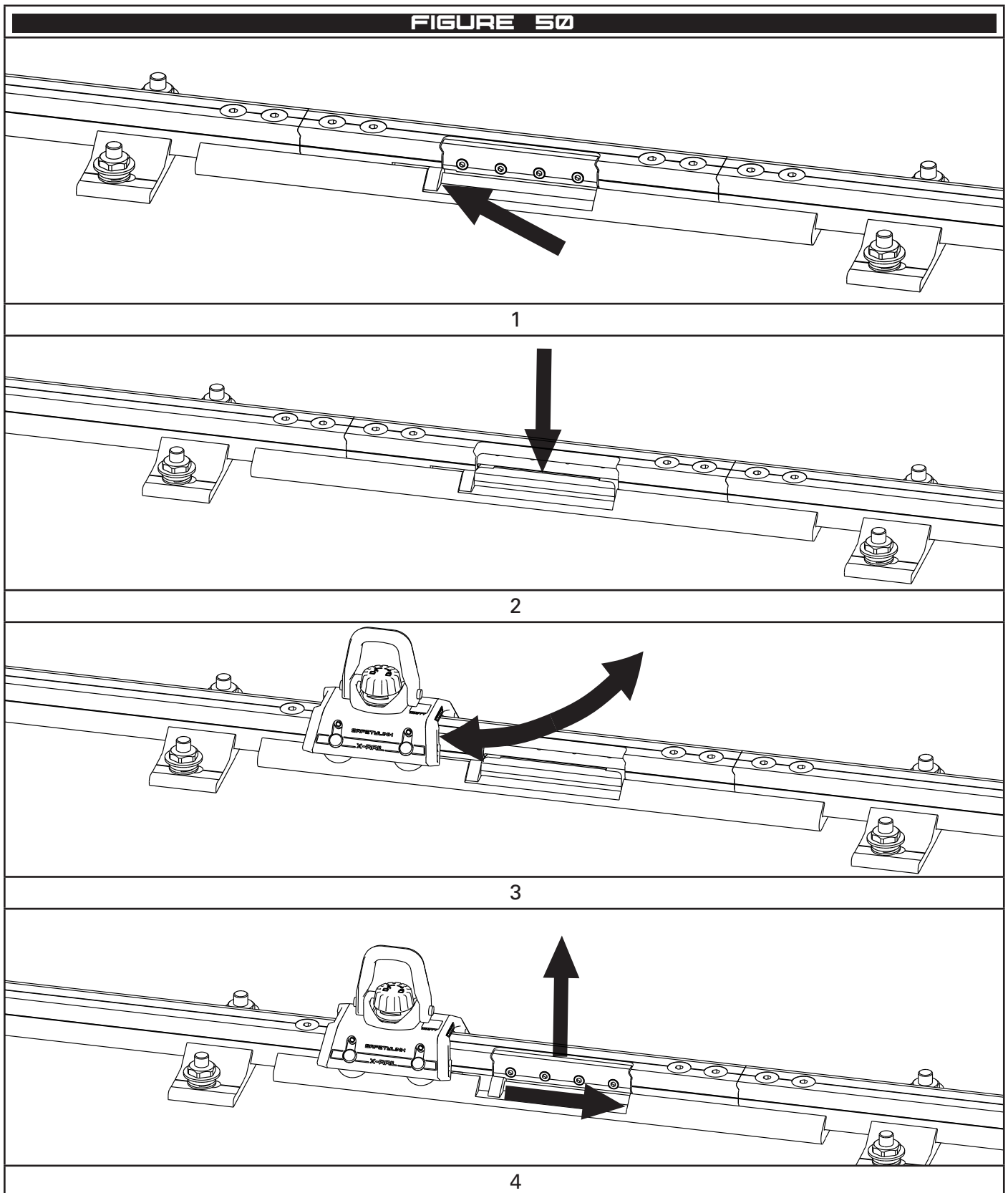

7.3 Shuttle Operation

Each shuttle type has 1 attachment for connection to the users system. Users shall load the shuttle only within the operation range in Figure 51. Shuttles TR-017A and TR-018 should be stored in a dry environment to prevent damage to the ball bearings.

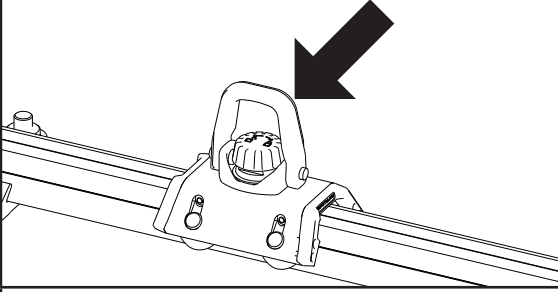
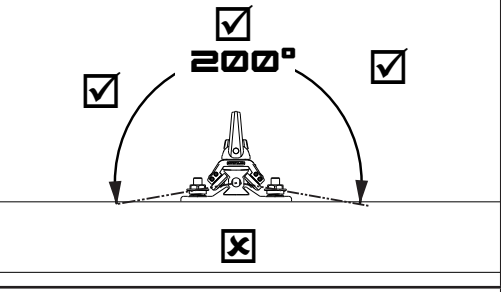
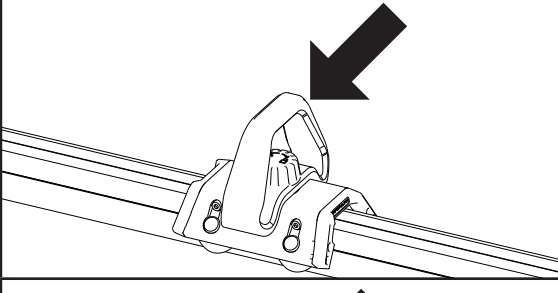
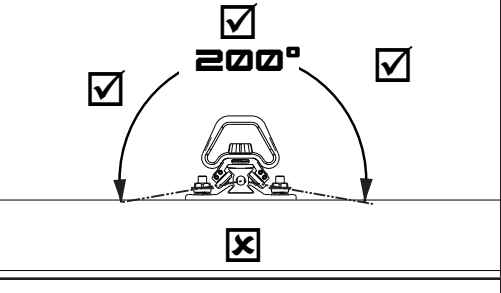
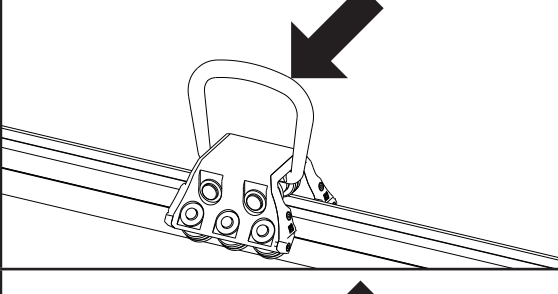
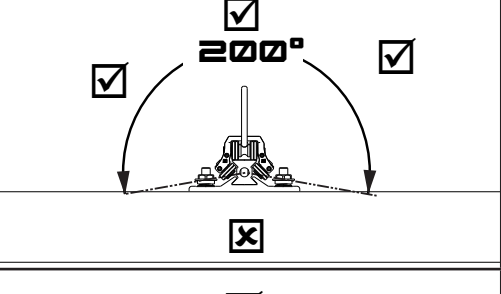
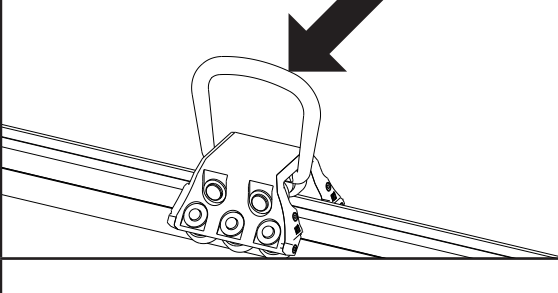
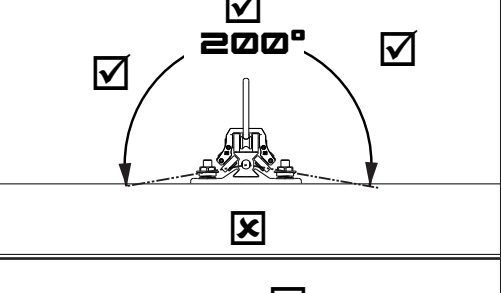
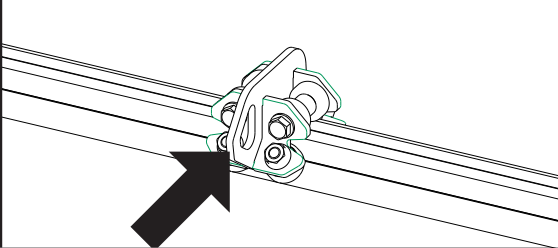
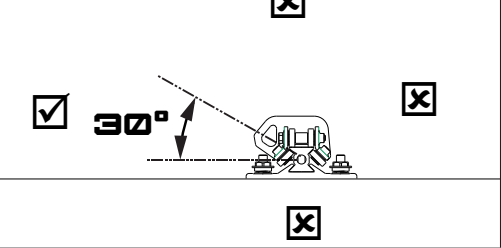
FIGURE 51		
PRODUCT CODE	ATTACHMENT POINT	OPERATING RANGE
TR-011 General use fall arrest, swivel attachment		
TR-014 General use fall arrest, fixed attachment		
TR-017 General use fall arrest and abseil, swing attachment		
TR-017A Specialty use abseil, swing attachment		
TR-018 Specialty use wall mounted abseil, fixed attachment		

- ⚠ Only attach to the attachment point indicated on the shuttle.**
- ⚠ Do not attach to any other point on the X-Rail.**
- ⚠ Do not attach multiple users to a single shuttle.**
- ⚠ Do not exceed the operating range of the shuttle.**

7.4 Single Point Anchor

7.4.1 Operation

The single point anchor has 1 attachment for connection to the users system.

Users shall load the anchor only within the operating range in Figure 52.

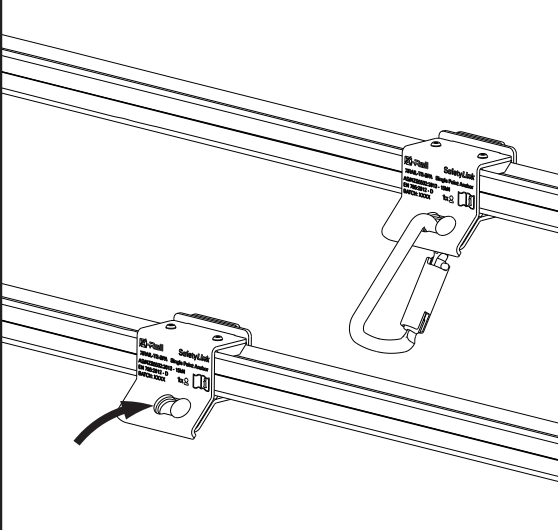
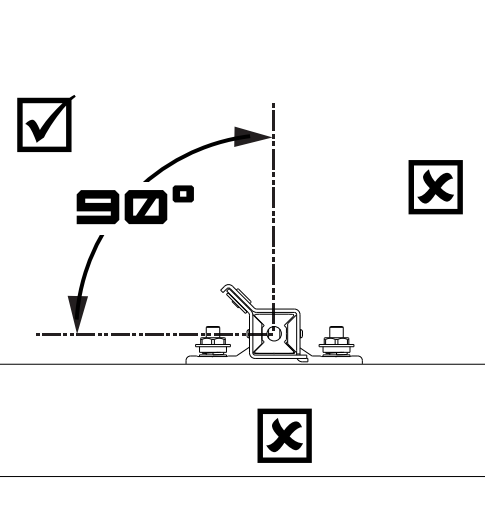
FIGURE 52		
PRODUCT CODE	ATTACHMENT POINT	OPERATING RANGE
TR-SPA Single point anchor for attachment at any point on the X-Rail system		

7.4.2 Limitations

The single point anchor is not suitable for attachment to a corner section of the system.

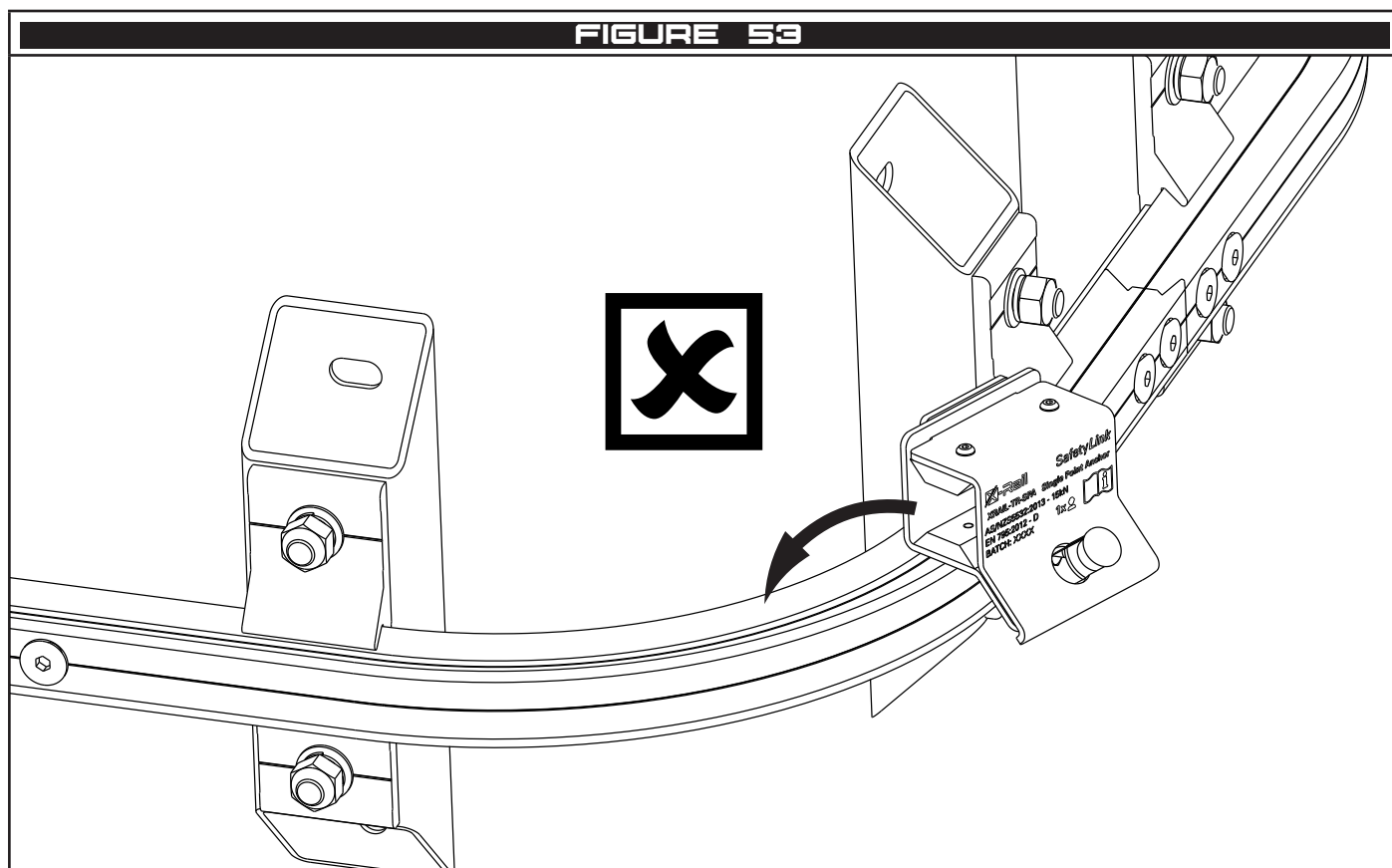

7.4.3 Installation

- 1 Slide the first body piece of the Single Point Anchor behind the rail.
- 2 Engage the second body piece with the first.
- 3 Rotate the second body piece to capture the rail.
- 4 Ensure the lock pin in the first body piece aligns with the hole in the second.
- 5 Slide the lock across to hold the two body pieces together.
- 6 Install a karabiner to prevent removal (karabiner not supplied).

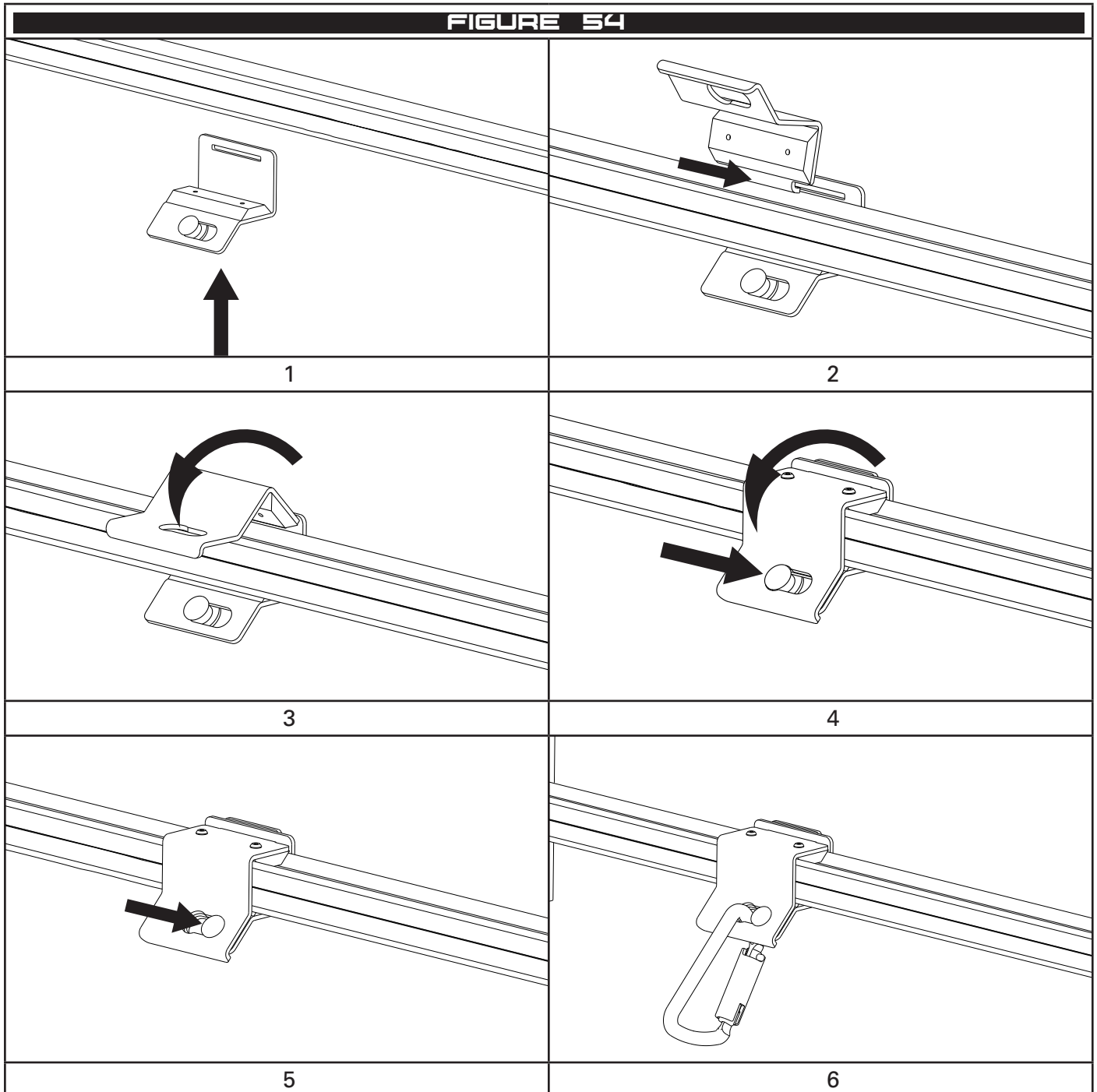

8 Storage, Transport and Maintenance

8.1 Storage and Transport

This equipment shall be stored and transported in a cool, dry environment, away from any hazards and out of direct sunlight.

8.2 Maintenance

8.2.1 The X-Rail system is serviceable only by trained and authorised installers. Contact SafetyLink to find your nearest available installer. The service interval will be determined by the condition in which it is used. Harsher conditions will require more frequent servicing. The equipment may remain in service until it fails an inspection or is involved in a fall.

⚠ Do not attempt to modify or disassemble this product.

8.3 Cleaning

The X-Rail Horizontal Rail System may be cleaned by the end user periodically to increase service life. After cleaning, the product shall undergo the pre-use inspection.

Clean with a rag and warm water to remove dirt and grit. A mild detergent may be used to remove grease or oils from the product.

⚠ Do not store this product when wet. Allow the product to dry and conduct a pre-use inspection prior to returning the item to service.

9 Inspection

9.1 Before and After Use

The X-Rail Horizontal Rail System shall be inspected before and after each use by the user.

9.2 Competent Person

A competent person shall inspect the system at least every 2 years. Systems installed in harsher conditions will require more frequent inspection. Installations in marine, coastal or other extreme corrosive environments should be inspected at least every 12 months.

9.3 Procedure

9.3.1 Rail - Inspect the rail for damage or deformation that may affect the strength. Inspect for dents or impact in the rail that may affect the smooth passage of a shuttle. Inspect all rail screws are torque tightened and free of corrosion and damage.

9.3.2 Support Brackets - Inspect the bracket for damage or deformation that may affect the strength. Inspect the fastener ensuring they are torque tightened correctly, free of corrosion or damage. Inspect the substrate is not deteriorating.

9.3.3 Gates - Ensure the mechanism works correctly and closes and locks automatically. Inspect for damage or deformation that may affect the strength.







9.3.4 Shuttle - Inspect the wheels rotate freely and are not loose or damaged. Inspect the attachment point is not worn or deformed. Check the attachment point pivots or swings (where applicable). Inspect the body for damage or deformation. Check all fasteners are tight and free of deformation.

9.3.5 Label - Inspect the system label is present and legible as per Figure 55.

9.3.6 Proof Load - for competent person inspections only, concrete fixings that do not extend through the concrete and are not cast in shall be proof loaded to 50% of the design load and held for 30 seconds.

INSPECTION RECORD			
Product Code		Date of Manufacture	
Serial or Batch No.		Date of Install	
Inspector		Date of Inspection	
PROCEDURE	INSPECTION	USER	COMPETENT PERSON
9.3.1	Rail - Inspect the rail for damage or deformation that may affect the strength. Inspect for dents or impact in the rail that may affect the smooth passage of a shuttle. Inspect all rail screws are torque tightened and free of corrosion and damage.	<input type="checkbox"/>	<input type="checkbox"/>
	Comments:		
9.3.2	Support Brackets - Inspect the bracket for damage or deformation that may affect the strength. Inspect the fastener ensuring they are torque tightened correctly, free of corrosion or damage. Inspect the substrate is not deteriorating.	<input type="checkbox"/>	<input type="checkbox"/>
	Comments:		
9.3.3	Gates - Ensure the mechanism works correctly and closes and locks automatically. Inspect for damage or deformation that may affect the strength.	<input type="checkbox"/>	<input type="checkbox"/>
	Comments:		
9.3.4	Shuttle - Inspect the wheels rotate freely and are not loose or damaged. Inspect the attachment point is not worn are deformed. Check the attachment point pivots or swings (where applicable). Inspect the body for damage or deformation. Check all fasteners are tight and free of deformation.	<input type="checkbox"/>	<input type="checkbox"/>
	Comments:		
9.3.5	Label - Inspect the system label is present and legible as per Figure 55.	<input type="checkbox"/>	<input type="checkbox"/>
	Comments:		
9.3.6	Proof Load - for competent person inspections only, concrete fixings that do not extend through the concrete and are not cast in shall be proof loaded to 50% of the design load and held for 30 seconds.	N/A	<input type="checkbox"/>
	Comments:		

FIGURE 55

X-Rail HORIZONTAL RIGID ANCHOR LINE				
NUMBER OF USERS	<input type="checkbox"/> 1x 	<input type="checkbox"/> 2x 	<input type="checkbox"/> 3x  <input type="checkbox"/> 4x 	
SYSTEM USE	<input type="checkbox"/> Fall Arrest		<input type="checkbox"/> Abseil	
INSTALL DATE	_/_/___ DD/MM/YYYY		INSTALLER	
STANDARDS	EN795:2012/D CEN/TS 16415:2013 AS/NZS 1891.2:2009		1X  / 	
 <p>A DIVISION OF DELTA PLUS</p> <p>SafetyLink Pty Ltd ABN 83 081 777 371 Phone: 1300 789 545 or +61 2 4964 1068 info@safetylink.com www.safetylink.com</p>	ONLY EVER CONNECT 1 USER TO EACH SHUTTLE			
	INSPECTION RECORD			
	1	_/_/___ DD/MM/YYYY	6	_/_/___ DD/MM/YYYY
	2	_/_/___ DD/MM/YYYY	7	_/_/___ DD/MM/YYYY
	3	_/_/___ DD/MM/YYYY	8	_/_/___ DD/MM/YYYY
	4	_/_/___ DD/MM/YYYY	9	_/_/___ DD/MM/YYYY
5	_/_/___ DD/MM/YYYY	10	_/_/___ DD/MM/YYYY	

SYSTEM LABEL

Warranties

EXTRACT: SAFETYLINK PTY LTD STANDARD TERMS AND CONDITIONS

- 1.1 To the extent permitted by law all implied conditions, warranties and undertakings are expressly excluded.
- 1.2 Except as provided in this clause the Company shall not be liable for any loss or damage, whether direct or indirect (including consequential losses or damage) arising out of any breach of contract by the Company or any negligence of the Company, its employees or agents.
- 1.3 Should the Company be liable for a breach of a guarantee, condition or warranty implied by the Australian Consumer Law (not being a guarantee, condition or warranty implied by sections 51, 52 and 53 of that Law) then its liability for a breach of any such condition or warranty express or implied shall be limited, at its option, to any one or more of the following.
- A in case of Goods
- I the replacement of the Goods or the supply of equivalent Goods.
 - II the repair of the goods,
 - III the payment of the cost of replacing the Goods or acquiring equivalent Goods.
 - IV the payment of the cost of having the Goods repaired. Provided that any such Goods are returned to the Company by the Purchaser at the Purchaser's expense.
- B in the case of services
- I the supply of the services again,
 - II the payment of the cost of having the services supplied again.
- 1.4 The Company is not liable for the costs of recovery of the Goods from the field, loss of use of the Goods, loss of time, inconvenience, incidental or consequential loss or damage, nor for any other loss or damage other than as stated above, whether ordinary or exemplary, caused either directly or indirectly by use of the Goods.
- 1.5 The Company warrants that at the time of shipment, Products manufactured by it will be free from defects in material and workmanship. In the absence of a modified written warranty, the Company agrees to making good any such defects by repairing the same or at the Company's option by replacement, for a period of (1) one year from the date of shipment. This limited warranty applies provided that:
- a defects have arising solely from faulty materials or workmanship;
 - b the Products have not received maltreatment, inattention or interference;
 - c the Products have been installed in accordance with the Company's Installation Handbooks using only products supplied by the Company;
 - d accessories used with the Products are manufactured by or approved by the Company
 - e the Products are maintained in accordance with Australian Standard 1891.4 (section 9).
 - f you notify any claim under this warranty to SafetyLink in writing to the address below no later than 14 days after the event or occurrence concerning the produce giving rise to the claim and you pay all costs related to your claim.
- This warranty does not apply to any defects or other malfunctions caused to the Goods by accident, neglect, vandalism, misuse, alteration, modification or unusual physical, environment or electrical stress.
- Please note that the benefits to the purchaser (as a consumer) given by this warranty are in addition to your other rights and remedies under the Australian Consumer Law. Our goods come with guarantees that cannot be excluded under the Australian Consumer Law. You are entitled to a replacement or refund for a major failure and compensation for any other reasonably foreseeable loss or damage. You are also entitled to have the goods repaired or replaced if the goods fail to be of acceptable quality and the failure does not amount to a major failure.
- 1.6 If any goods are not manufactured by the Company, the guarantee of the manufacturer thereof shall be accepted by the Purchaser as the only express warranty given in respect of the goods.
- 1.7 Except as provided in this clause 11, all express and implied warranties, guarantees and conditions under statute or general law as the merchantability, description, quality, suitability or fitness of the Products for any purpose or as to design, assembly, installation, materials or workmanship or otherwise are hereby expressly excluded (to the extent to which they may be excluded by law).

PLEASE SEE SAFETYLINK PTY LTD FULL STANDARD TERMS OF CONDITIONS OF SALE FOR FURTHER REFERENCE.



SafetyLink Pty Ltd | ABN 83 081 777 371 | www.safetylink.com

Head Office: 54 Bonville Ave, Thornton, 2322, NSW, Australia

+64 2 4964 1068 | 1300 789 545

Asia-Pacific/The Americas | info@safetylink.com

Europe/Africa/Middle East | europe.sales@safetylink.com

Northern Europe | uk.sales@safetylink.com