



FastFit Davit

Temporary Anchor

Installation and Use



FastFit
Davit



SCAN ME
INSTALLATION



SCAN ME
CATALOGUE



SCAN ME
WEBSITE

CONTENTS

1	Warning	4
2	Specification	4
2.1	Description	4
2.2	Standard	4
2.3	User Rating.....	4
2.4	Material Specification and Components.....	5
3	Layout and Selection	13
3.1	Layout	13
3.1.1	<i>Base Spacing</i>	13
3.1.2	<i>Unreachable Area</i>	14
3.1.3	<i>Use</i>	14
3.1.4	<i>Height and Reach</i>	15
3.1.5	<i>Wall Mount Base Clearances</i>	16
3.1.6	<i>Dropped Objects</i>	16
3.2	Reaction Loads.....	17
4	Installation	19
4.1	Fixings	19
4.1.1	<i>General</i>	19
4.1.2	<i>Steel</i>	19
4.1.3	<i>Concrete 3rd Party</i>	19
4.2	Floor Mounted Bases Installation.....	20
4.2.1	<i>Concrete - DonutLink (Floor Mounted Bases)</i>	20
4.2.2	<i>Concrete Inserts Stainless Steel CONCL013</i>	21
4.2.3	<i>Concrete Inserts Galvanised CONCL014</i>	22
4.2.4	<i>Cast in Cage</i>	24
4.2.5	<i>Concrete - DonutLink (DAVIT_BASE09)</i>	25
4.2.6	<i>Base Installation (Galvanised)</i>	26
4.2.7	<i>Planter Base Installation (Stainless steel)</i>	27
4.2.8	<i>Proof Loading Standard Floor Mounted Bases</i>	28
4.2.9	<i>Installation of Planter Base Proof Loading Kit</i>	29
4.2.10	<i>Proof Loading of Planter Bases</i>	30

4.3	Removeable Base Sleeve.....	31
4.4	Wall Mounted Bases.....	32
	4.4.1 Concrete - DonutLink (Wall Mounted Bases).....	32
	4.4.2 Base Installation.....	33
	4.4.3 Proof Loading Wall Mounted Base.....	33
4.5	Wall Mounted Removeable Base Sleeve	34
4.6	Base Cap.....	35
4.7	Mast and Boom Assembly.....	36
5	Limitations of Use	37
5.1	Fall Clearance	37
5.2	Swing Fall.....	37
5.3	Area of Use.....	38
5.4	Hazards	38
5.5	Training.....	38
5.6	Rescue	38
5.7	Materials Handling	38
6	Connections	39
6.1	Making Connection.....	39
6.2	Compatibility of Connections	39
7	Use	40
7.1	Planning.....	40
7.2	FastFit Davit	40
8	Storage, Transport and Maintenance	41
8.1	Storage and Transport.....	41
8.2	Maintenance.....	41
8.3	Cleaning.....	41
9	Inspection	41
9.1	Before and After Use	41
9.2	Competent Person	41
9.3	Procedure	41

1 Warning

- ⚠** *Improper Use, Installation or Maintenance may result in serious injury or death.*
- ⚠** *The structure or anchorage to which SafetyLink products are to be installed shall be assessed by a professional engineer to ensure it has adequate strength to support the product.*
- ⚠** *SafetyLink products shall be installed, used and maintained in accordance with the applicable SafetyLink installation and use manual.*
- ⚠** *SafetyLink's product shall be used in accordance with the current working at height standards, codes of practice, regulation or legislation in the region of use.*
- ⚠** *During installation, use and maintenance, personnel shall not be exposed to a fall hazard.*
- ⚠** *Installation is to be carried out by, or under the supervision of, a competent person.*
- ⚠** *The installer shall complete the applicable SafetyLink online training modules before installing this product.*
- ⚠** *Connection systems used with SafetyLink Anchor, Lifelines and Rigid Rail Systems shall contain a personal energy absorber.*
- ⚠** *Do not carry out any modifications to this product without written permission from SafetyLink.*

2 Specification

2.1 Description

The SafetyLink FastFit Davit is a temporary anchor suitable for use as part of a personal fall protection system. The FastFit Davit is suitable for having one user suspended from the shuttle and a second user connected to either of the secondary attachment points (Mast or Base). All attachment points are suitable for abseil or fall arrest.

- ⚠** *Only one user shall be suspended from the Davit's shuttle or secondary attachment points at a time.*

2.2 Standard



The FastFit Davit temporary anchor system is compliant with AS/NZS 5532.



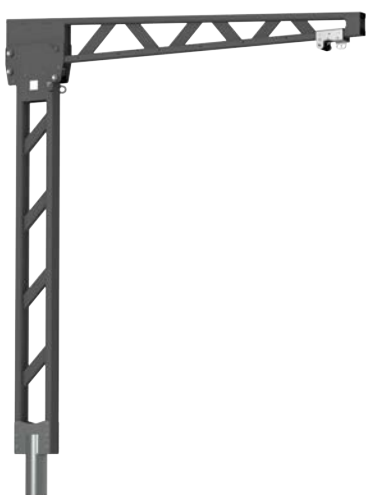
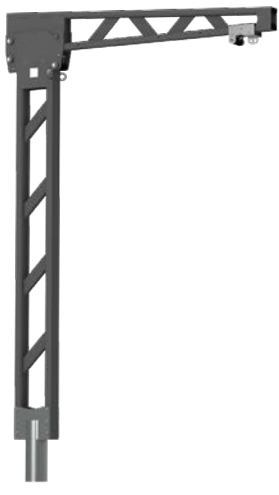
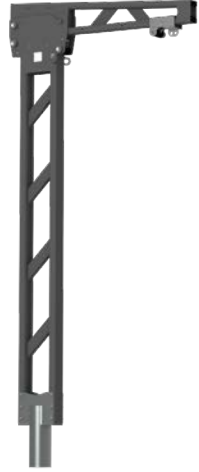
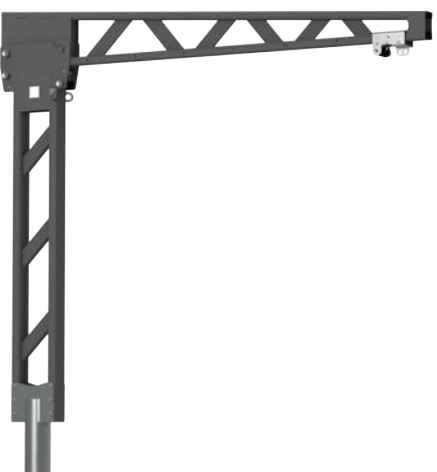

2.3 User Rating

The FastFit Davit is rated for one user with a maximum weight of 150kg suspended from the shuttle and one user connected to either of the secondary attachment points with a maximum weight of 150kg.

2.4 Material Specification and Components

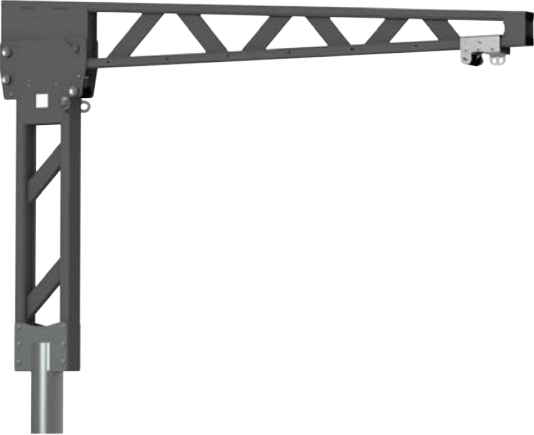
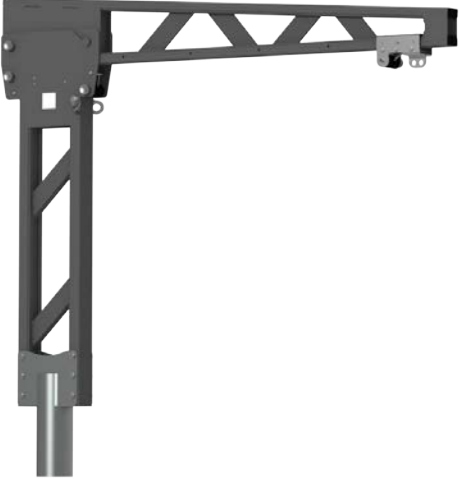
Figure 1

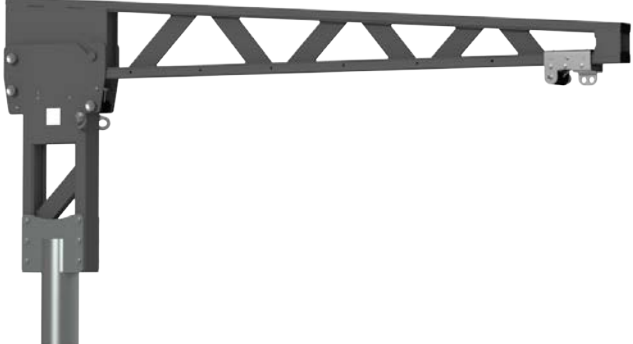
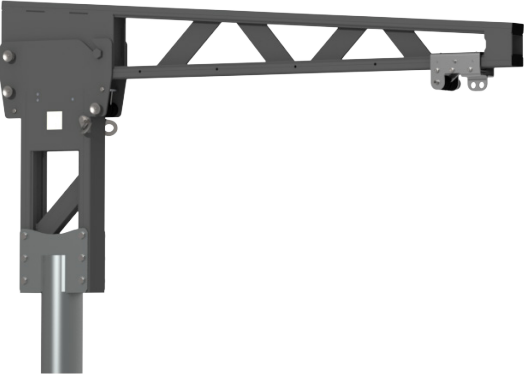
	
<p>DAVIT_KIT.BL28.22</p>	<p>DAVIT_KIT.BL28.16</p>
<p>Aluminium, Stainless steel, Galvanised steel</p>	<p>Aluminium, Stainless steel, Galvanised steel</p>
	
<p>DAVIT_KIT.BL28.10</p>	<p>DAVIT_KIT.BL22.22</p>
<p>Aluminium, Stainless steel, Galvanised steel</p>	<p>Aluminium, Stainless steel, Galvanised steel</p>
	
<p>DAVIT_KIT.BL22.16</p>	<p>DAVIT_KIT.BL22.10</p>
<p>Aluminium, Stainless steel, Galvanised steel</p>	<p>Aluminium, Stainless steel, Galvanised steel</p>

	
<p align="center">DAVIT_KIT.BL16.22</p>	<p align="center">DAVIT_KIT.BL16.16</p>
<p>Aluminium, Stainless steel, Galvanised steel</p>	<p>Aluminium, Stainless steel, Galvanised steel</p>
	
<p align="center">DAVIT_KIT.BL16.10</p>	<p align="center">DAVIT_KIT.BL10.22</p>
<p>Aluminium, Stainless steel, Galvanised steel</p>	<p>Aluminium, Stainless steel, Galvanised steel</p>
	
<p align="center">DAVIT_KIT.BL10.16</p>	<p align="center">DAVIT_KIT.BL10.10</p>
<p>Aluminium, Stainless steel, Galvanised steel</p>	<p>Aluminium, Stainless steel, Galvanised steel</p>



DAVIT_BOOM22.BL

Aluminium, Stainless steel



DAVIT_BOOM16.BL

Aluminium, Stainless steel



DAVIT_BOOM10.BL

Aluminium, Stainless steel



DAVIT_MAST28.BL

Aluminium, Galvanised steel



DAVIT_MAST22.BL

Aluminium, Galvanised steel



DAVIT_MAST16.BL

Aluminium, Galvanised steel



DAVIT_MAST10.BL

Aluminium, Galvanised steel



DAVIT_SHUTTLE

Stainless steel



DAVIT_BASE01

Galvanised steel



DAVIT_BASE02

Galvanised steel



DAVIT_BASE02.01

Galvanised steel



DAVIT_BASE02.02

Galvanised steel



DAVIT_BASE02.WP

Galvanised steel



DAVIT_BASE02.04

Galvanised steel

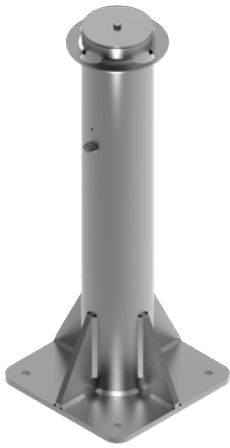

DAVIT_BASE07.1000

Stainless steel

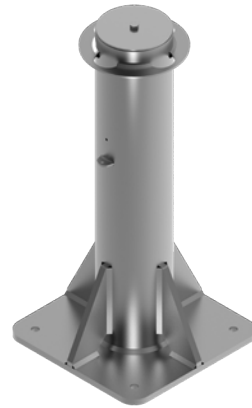

DAVIT_BASE07.800

Stainless steel



DAVIT_BASE07.600

Stainless steel



DAVIT_BASE07.400

Stainless steel



DAVIT_BASE08.1000

Galvanised steel



DAVIT_BASE08.800

Galvanised steel



DAVIT_BASE08.600

Galvanised steel



DAVIT_BASE08.400

Galvanised steel



DAVIT_BASE04

Galvanised steel



DAVIT_BASE04.01

Galvanised steel



DAVIT_BASE04.02

Galvanised steel



DAVIT_BASE10

Galvanised steel

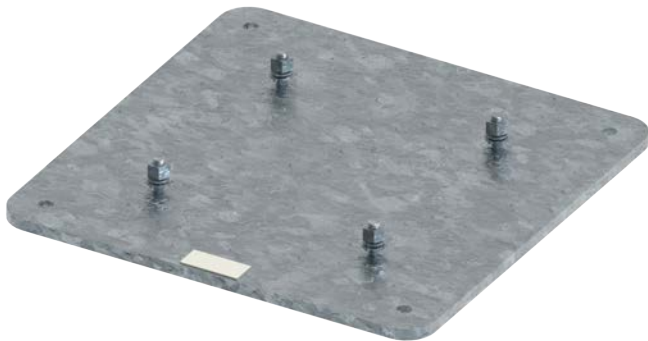

DAVIT_BASE09

Galvanised steel

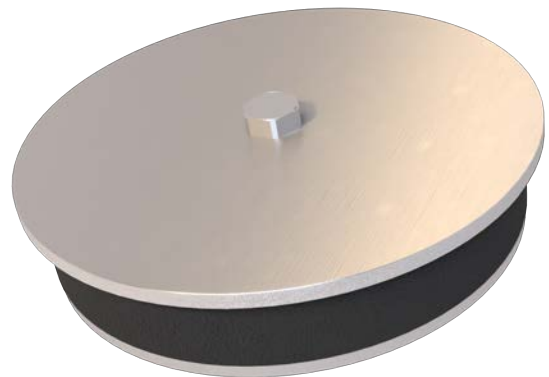

DAVIT_BASE.CAP

Stainless steel, EPDM



DAVIT_BASE07.PROOF

Stainless steel, PVC



DAVIT_BASE07.TOOL

Galvanised steel

		
DAVIT_BASE05 Galvanised Steel	DAVIT_BASE05-SS Stainless Steel	CON-M16X200-DONUT Stainless Steel, Nylon
		
CONCL013 Stainless Steel		DAVIT_BASE.SLEEVE PVC
		
CONCL014 Galvanised steel		DAVIT_BASE01.WP Galvanised steel

3 Layout and Selection

3.1 Layout

3.1.1 Base Spacing

Systems shall be designed to limit free fall, swing fall and maximise fall clearance. Davit bases shall be spaced to ensure that the work area can be reached. Figure 2 shows the coverage of each product for a series of offsets.

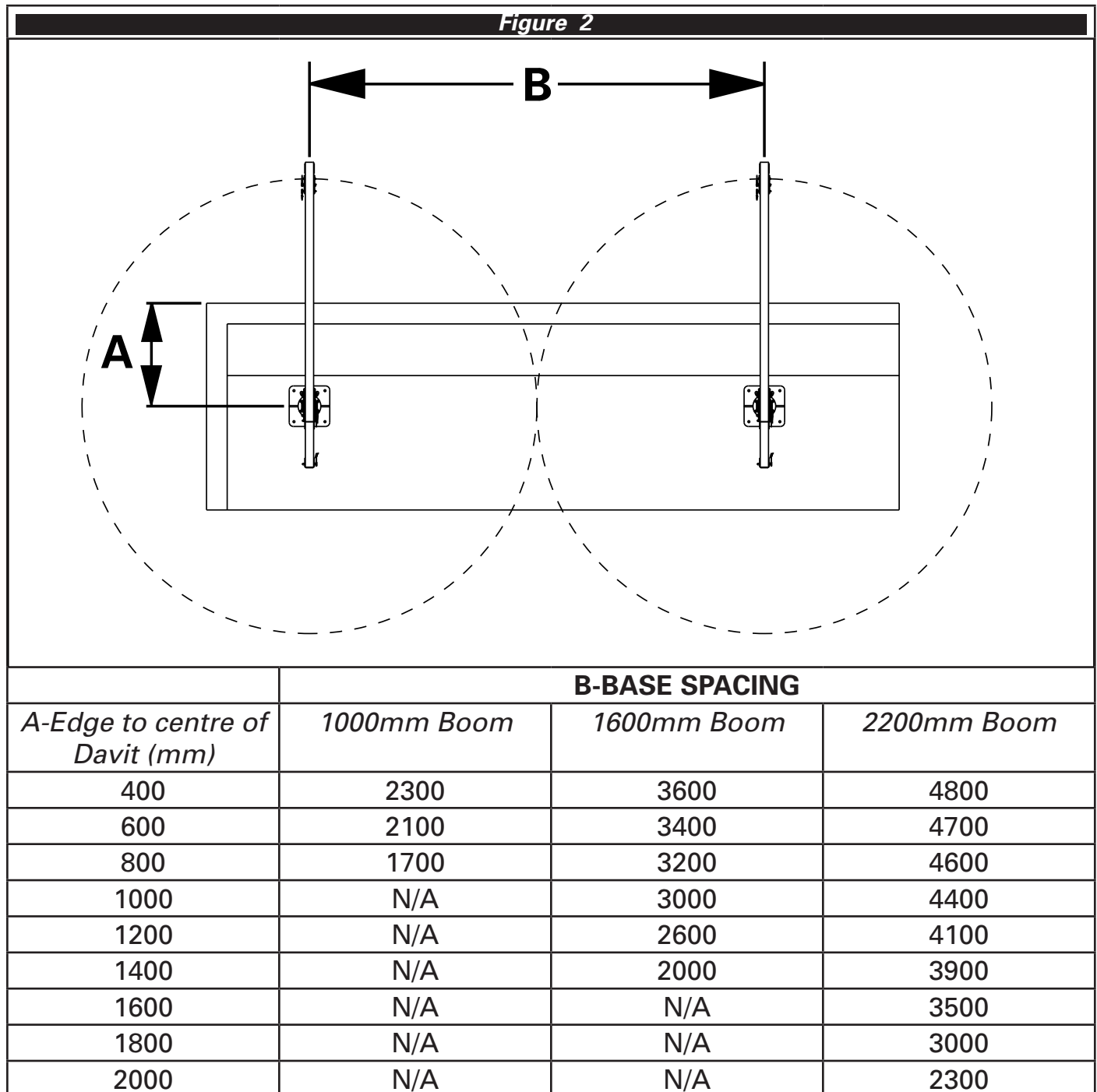

3.1.2 Unreachable Area

The unreachable area (C) between work areas of the edge should be limited to approximately 500mm.

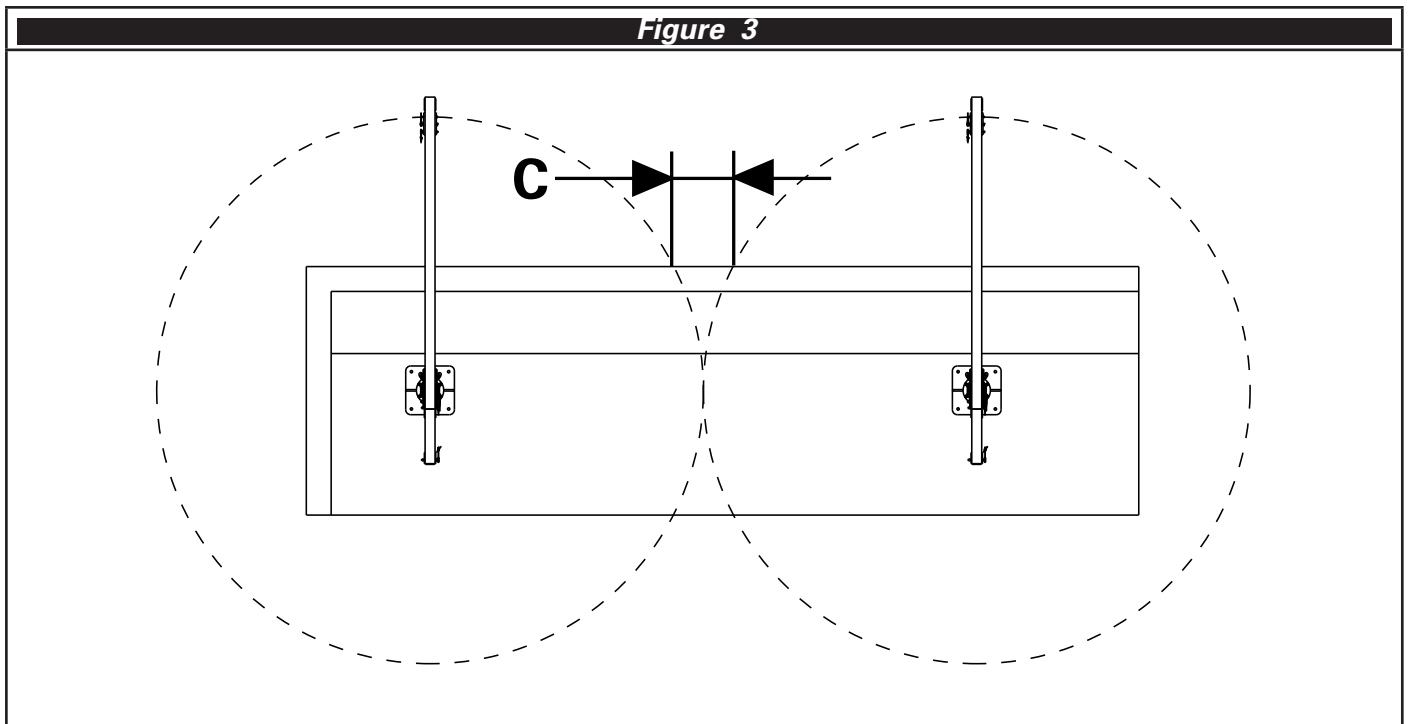

3.1.3 Use

Ensure the placement of bases allows the work to be conducted inside the 30° operating angle of the product. See Figure 4.

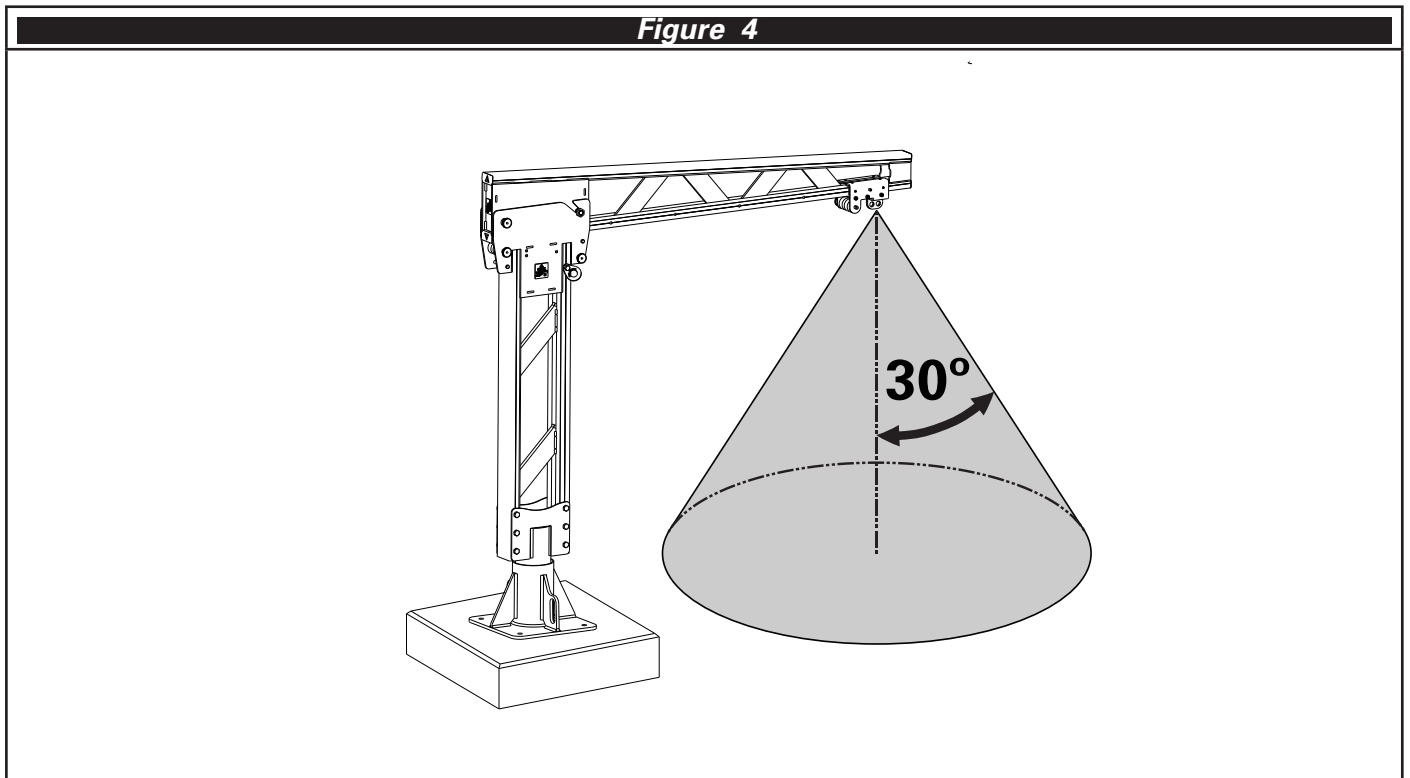

3.1.4 Height and Reach

Ensure that the selected davit size will have sufficient clearance over the parapet, balustrade or other obstruction. Under load, some deflection of the davit can be expected. Figure 5 outlines the typical maximum expected deflections that should be accounted for when setting out the davit base locations. Where possible, more clearance around the davit should be accounted for.

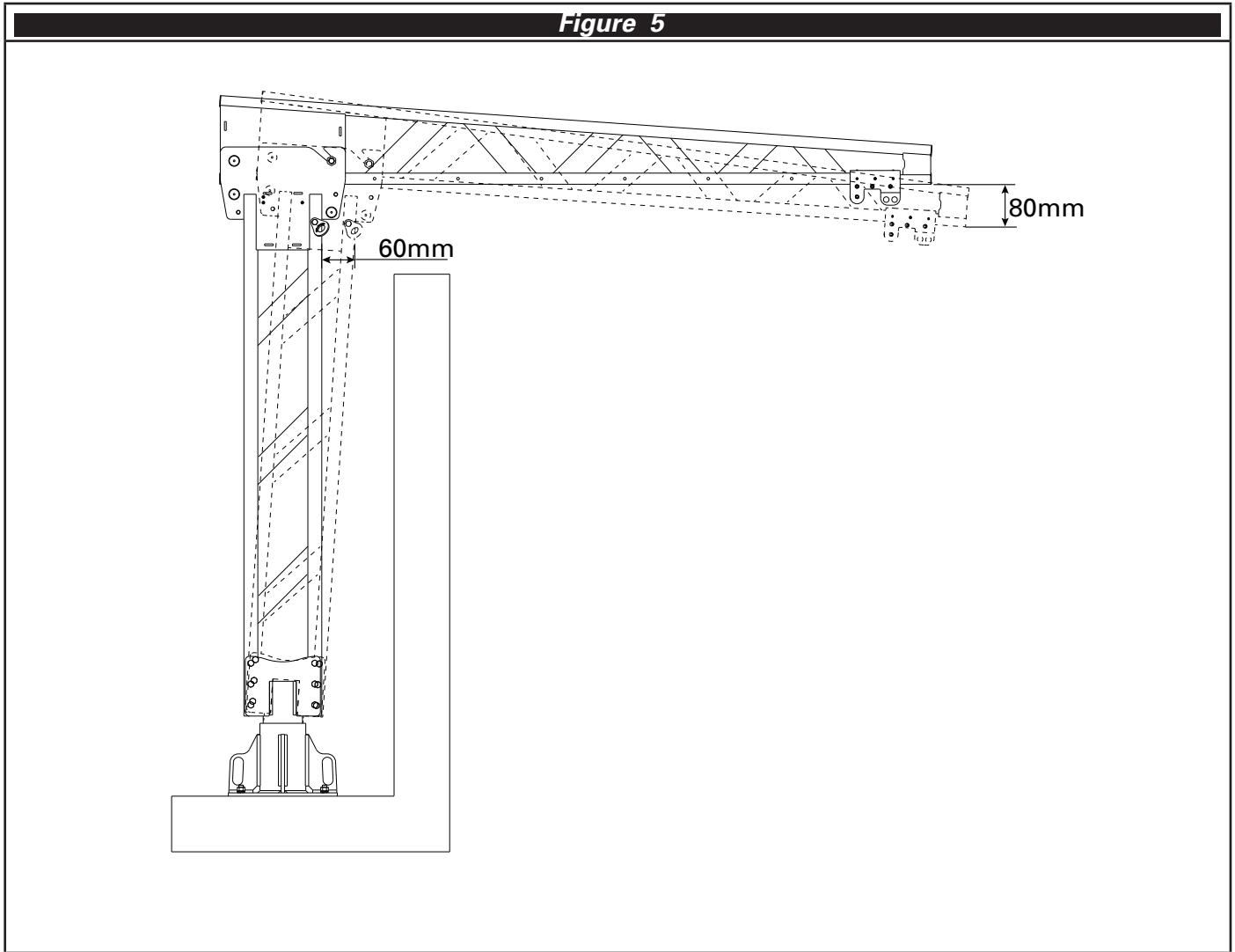

3.1.5 Wall Mount Base Clearances

Consideration should be made for any potential obstructions to the installation of wall mounted bases. Parapet walls may have conduits, lights, cappings/copings and waterproofing membranes which can obstruct the installation of the base. Figure 6 displays the minimum clearances required to avoid typical obstructions.

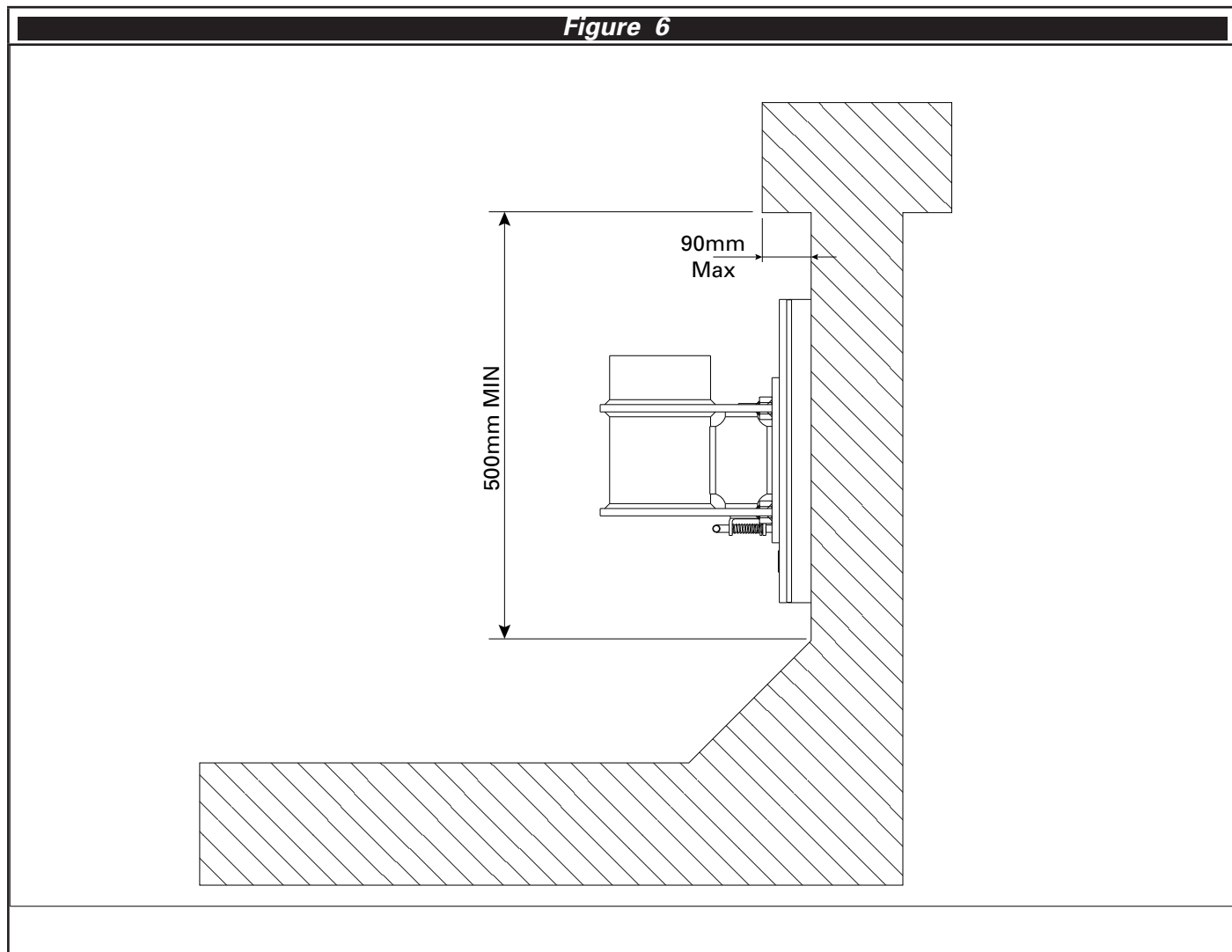

3.1.6 Dropped Objects

Bases should be positioned such that the assembly of the davit or the davit base will not create a risk of falling or dropped objects. Ensure the relevant base installation instructions are followed regarding slab edge distance and depth.

3.2 Reaction Loads

The substrate must be able to sustain the reaction loads in Figure 7 to Figure 10 for this product to be installed.

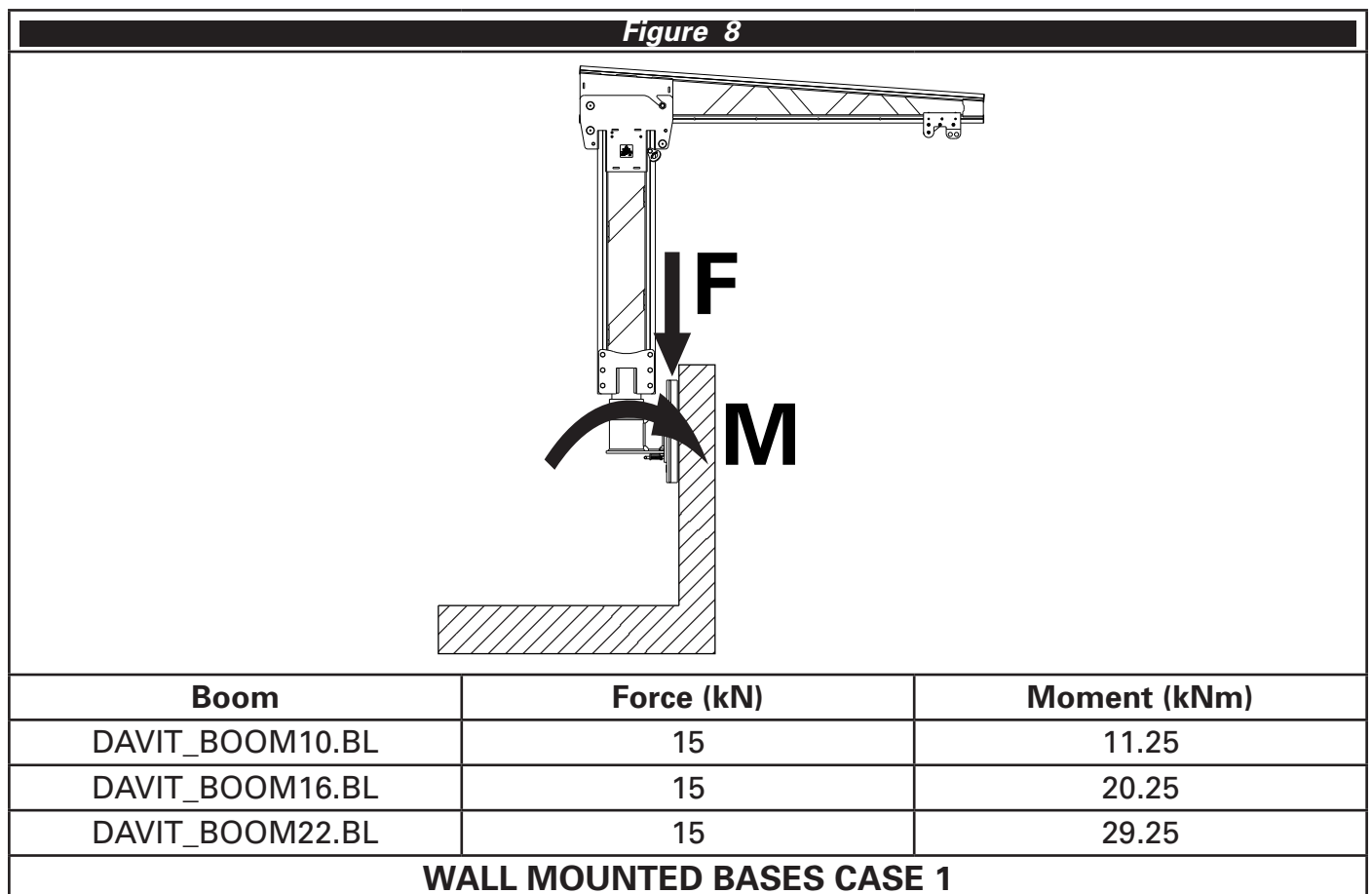
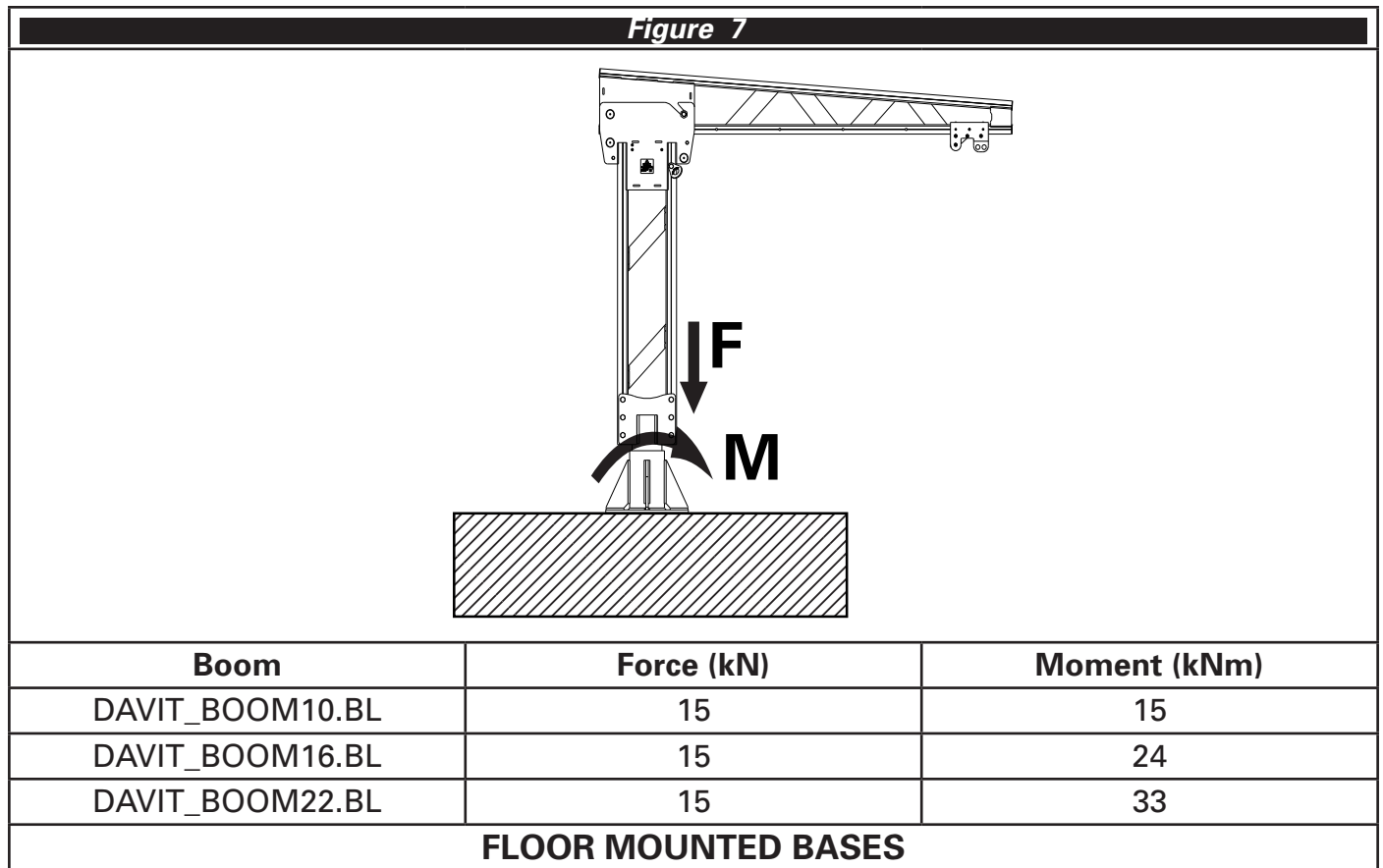
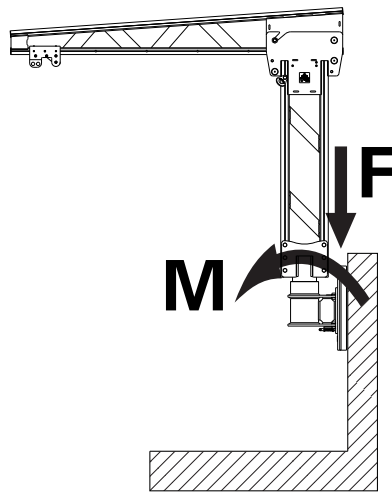

Figure 9



Boom	Force (kN)	Moment (kNm)
DAVIT_BOOM10.BL	15	18.75
DAVIT_BOOM16.BL	15	27.75
DAVIT_BOOM22.BL	15	36.75

WALL MOUNTED BASES CASE 2

Figure 10

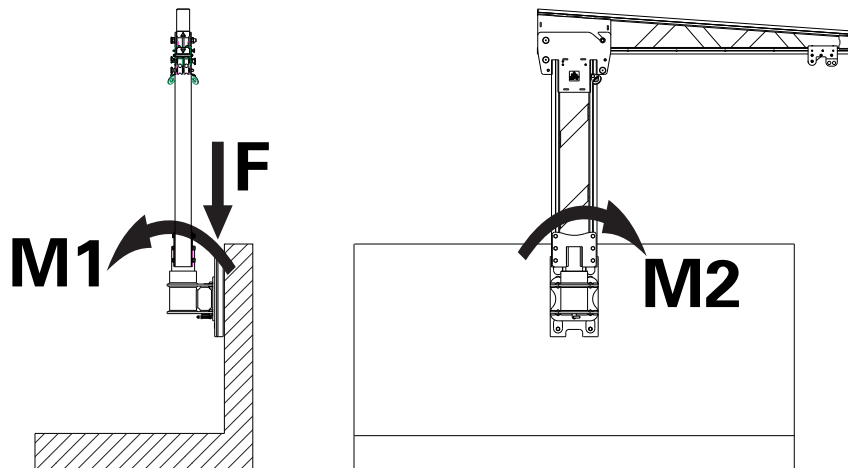

Boom	Force (kN)	Moment 1 (kNm)	Moment 2 (kNm)
DAVIT_BOOM10.BL	15	3.75	15
DAVIT_BOOM16.BL	15	3.75	24
DAVIT_BOOM22.BL	15	3.75	33

WALL MOUNTED BASES CASE 3

- ⚠ All load cases shall be considered by a trained engineer.**
- ⚠ The above cases represent the standard installation configurations, specific installations may require additional load case investigation.**
- ⚠ If an installation is designed for only a 1m or 1.6m Boom, it shall be permanently marked on the base label and documented accordingly.**
- ⚠ Load cases shall be assessed for all directions the boom can face.**
- ⚠ For wall mounted bases, post fix concrete fasteners may not be suitable for use with boom DAVIT_BOOM22.BL. Contact SafetyLink for more information.**

4 Installation

4.1 Fixings

4.1.1 General

All fixings used to attach the FastFit Davit System to the substrate that were not supplied by SafetyLink shall be M16 (5/8") in diameter. Fixings shall be stainless steel grade 316 or 304 or hot dip galvanised or zinc plated steel grades 8.8 or 8. Fixings shall be installed with spring washers, lock nuts or thread lock adhesive to prevent loosening. Once tight, a minimum of 2 threads shall extend past the end of the nut

⚠ SafetyLink does not recommended the use of zinc plated fasteners in a corrosive or outdoor environment.

4.1.2 Steel

For installation on a steel structure, SafetyLink recommends the use of appropriate hex head screws or bolts meeting the requirements of Section 4.1.1. Fixings shall be tightened to 70Nm and once tight, a minimum of 2 threads shall extend past the end of the nut.

4.1.3 Concrete 3rd Party

In addition to the part numbers specified in Sections 4.2.1, 4.2.2 and 4.4.1, SafetyLink allows the use of a variety of chemical and mechanical fixings for installation of the Fast Fit Davit into concrete. Refer to the manufacturer's instruction for proper preparation, installation, edge distance and embedded depth.

⚠ All fixings shall meet the load requirements specified in Section 4.1.1. Consult the manufacturer to assess the suitability of the below product.

⚠ All chemical and mechanical fixings shall be proof loaded after install as per AS/NZS 1891.4 or the appropriate local regulation. See Section 4.2.8.

4.2 Floor Mounted Bases Installation

SafetyLink's floor mounted davit bases can be installed using three different fixing types; DonutLink studs, concrete inserts and cast in cages. Ensure the correct specific requirements are followed for each fixing method.

4.2.1 Concrete - DonutLink (Floor Mounted Bases)

SafetyLink's DonutLink M16 Concrete Stud (CON-M16X200-DONUT) are to be installed with chemical adhesive (CON-CHEM-FISV.300).

⚠ Minimum 32MPa uncracked concrete slab

⚠ Minimum 200mm slab thickness

⚠ Minimum slab edge distance 250mm

⚠ Embedded Depth 140mm

1 Mark the location for the hole and drill an $\text{Ø}18\text{mm}$ hole to a depth of 140mm. Clean the hole, ensuring it is free of moisture and dust and inject the adhesive into the hole as per the manufacturer's instruction.

2 Insert the stud to full depth, a minimum of 45mm of the stud should remain above the surface. Wipe away any adhesive expelled from the hole.

⚠ Ensure enough adhesive was used, the adhesive should finish flush with the concrete.

The DonutLink can be proof loaded with the Pull Test Adaptor (DONUTLINK-ADP) and a Hydrajaws portable tension tester, see Section 4.2.8.

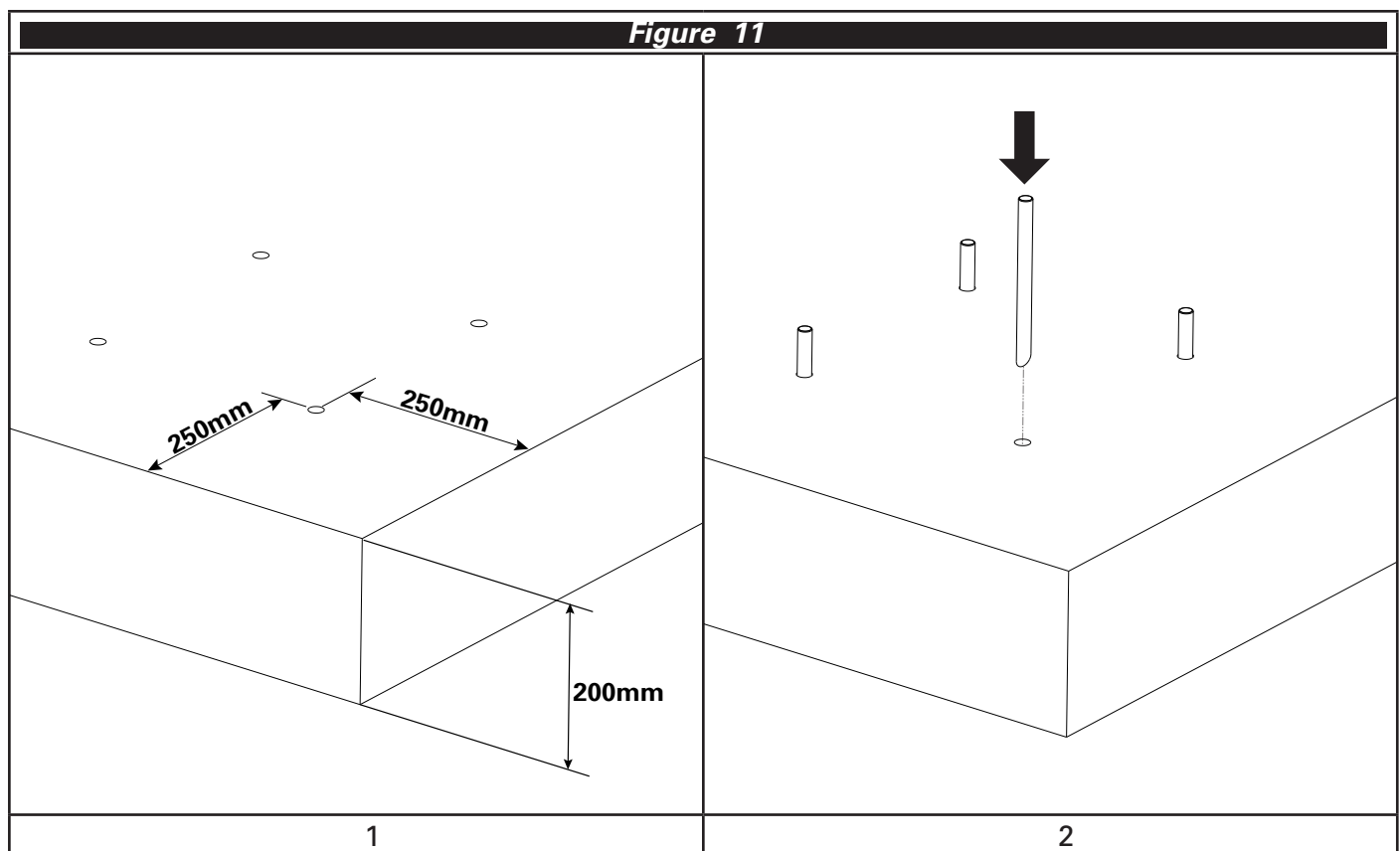

4.2.2 Concrete Inserts Stainless Steel CONCL013

SafetyLink's DonutLink M16 Concrete Inserts (CONCL013) are to be installed with chemical adhesive (CON-CHEM-FISV.300).

⚠ Minimum 32MPa uncracked concrete slab

⚠ Minimum 200mm slab thickness

⚠ Minimum slab edge distance 200mm

⚠ Embedded Depth 125mm

- 1 Mark the location for the holes and drill a $\varnothing 28\text{mm}$ hole to a depth of 125mm. The jig CONCL013_JIG should be used to ensure the holes are in the correct position. Clean the hole, ensuring it is free of moisture and dust and inject the adhesive into the hole as per the manufacturer's instruction.
- 2 Install the concrete insert to full depth, the top of the insert should be flush with the surface. Wipe away any adhesive expelled from the hole.

⚠ Ensure enough adhesive was used, the adhesive should finish flush with the concrete.

The DonutLink can be proof loaded with the Pull Test Adaptor (DONUTLINK-ADP) and a Hydrajaws portable tension tester, see Section 4.2.8.

⚠ Proof loading of the Concrete Inserts as per AS/NZS 1891.4 is required every time that a base is installed. If the base is removed and moved to another location, the concrete inserts must be proof loaded again. Check the specific requirements for proof loading of each davit base.

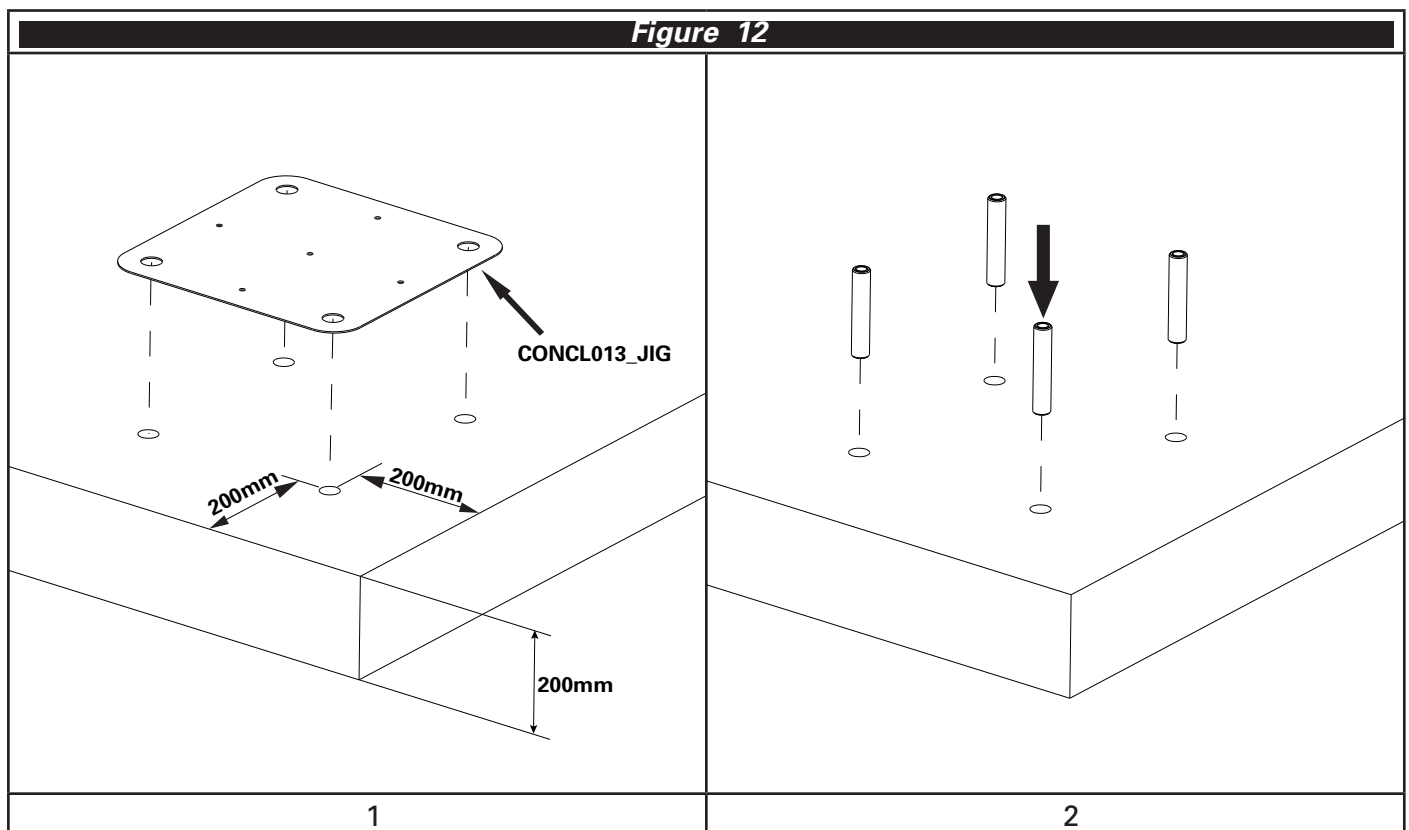

4.2.3 Concrete Inserts Galvanised CONCL014

SafetyLink's DonutLink M16 Concrete Inserts (CONCL014) are to be installed with chemical adhesive (CON-CHEM-FISV.300).

- ⚠ Minimum 32MPa uncracked concrete slab**
- ⚠ Minimum 200mm slab thickness**
- ⚠ Minimum slab edge distance 250mm**
- ⚠ Minimum embedded depth of M16 rod into structural concrete 140mm.**
- ⚠ Maximum grout thickness above structural slab 100mm**

- 1 Mark the location for the holes and drill a $\text{Ø}28\text{mm}$ hole to a depth of 60mm. Then drill each hole further with an $\text{Ø}18\text{mm}$ drill, until the hole is at least 140mm deep into the structural concrete. Clean the hole, ensuring it is free of moisture and dust and inject the adhesive into the hole as per the manufacturer's instruction.
- 2 Install the concrete insert to full depth, the top of the insert should be flush with the surface. Wipe away any adhesive expelled from the hole.

- ⚠ Ensure enough adhesive was used, the adhesive should finish flush with the concrete.**

The DonutLink can be proof loaded with the Pull Test Adaptor (DONUTLINK-ADP) and a Hydrajaws portable tension tester, see Section 4.2.8.

- ⚠ Proof loading of the Concrete Inserts as per AS/NZS 1891.4 is required every time that a base is installed. If the base is removed and moved to another location, the concrete inserts must be proof loaded again. Check the specific requirements for proof loading of each davit base.**

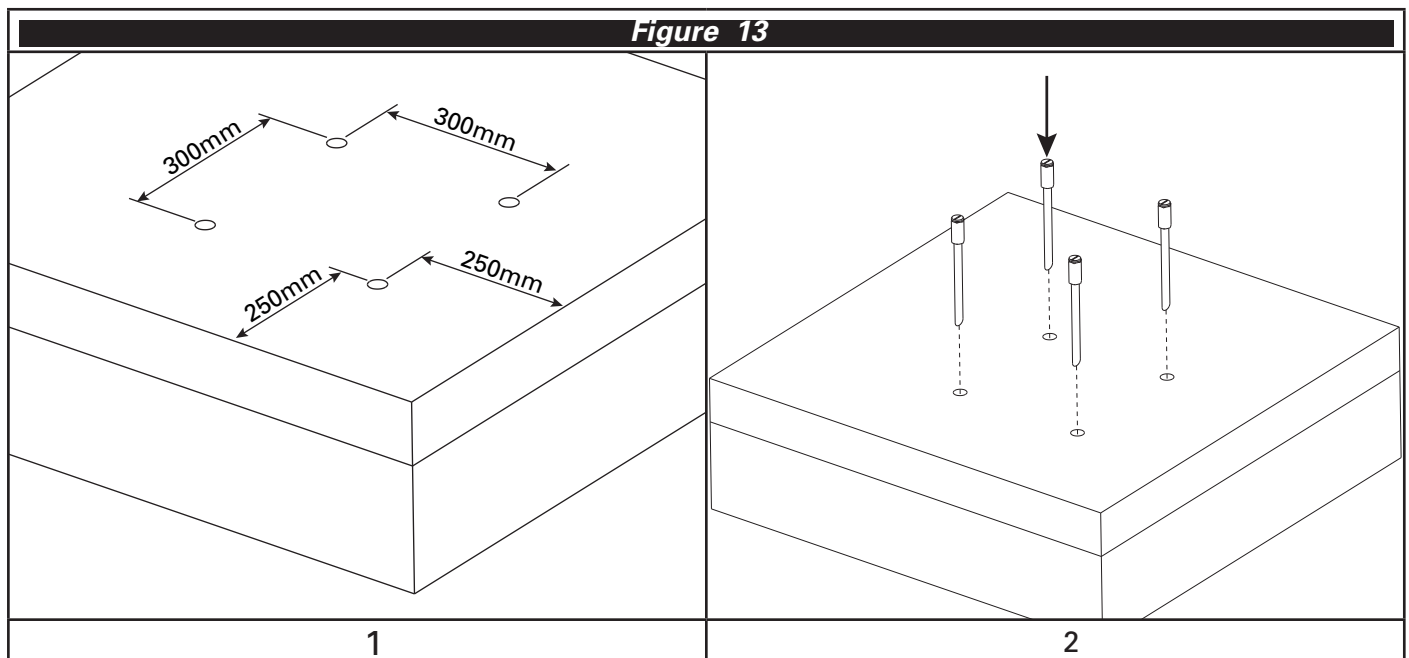

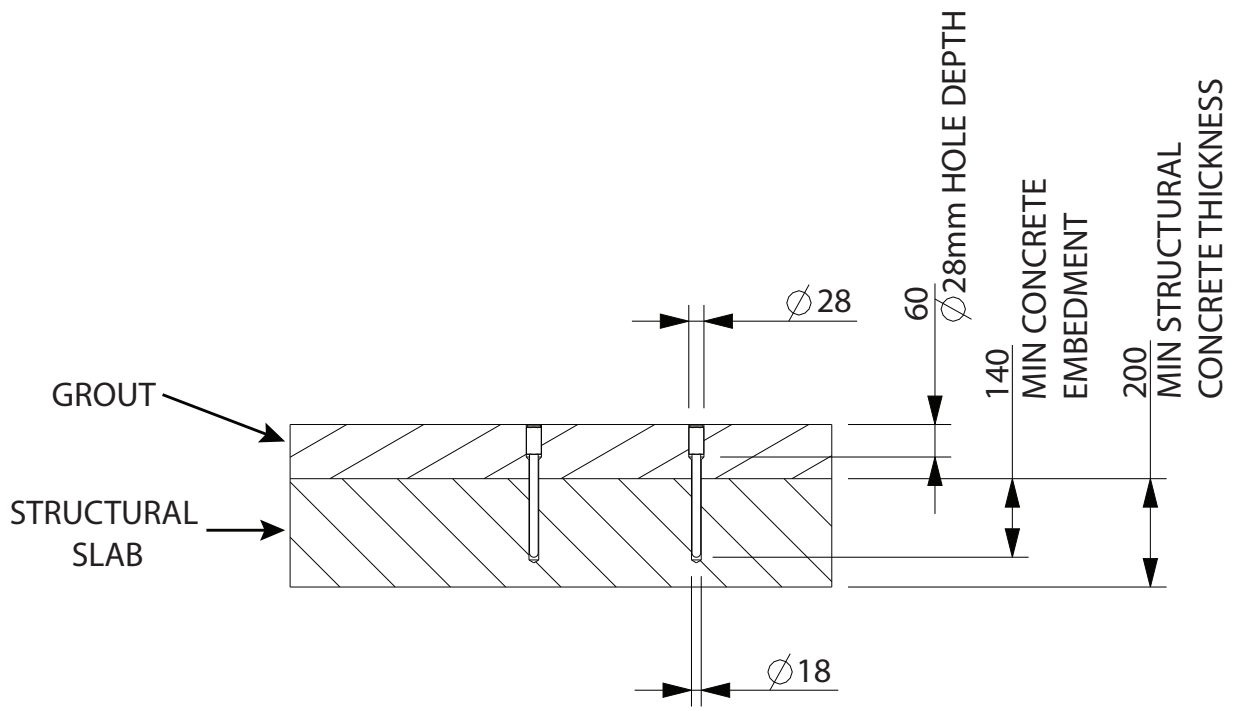

4.2.4 Cast in Cage

To avoid ongoing proof loading, floor mounted bases can be installed with a cast in cage.

⚠ **Minimum 32MPa uncracked concrete slab**

⚠ **Minimum 200mm slab thickness**

⚠ **Minimum slab edge distance 200mm**

⚠ **Embedded Depth 140mm**

- 1 Attach the four studs to the two template pieces with the nuts provided to form a square.
- 2 Position the studs in the slab with a minimum edge distance of 200mm and embedment of 140mm.
- 3 Join the two adjacent studs with the lengths of reinforcement steel provided below the slab reinforcement.
- 4 Tie the steel to the slab reinforcement to prevent movement during the concrete pour.

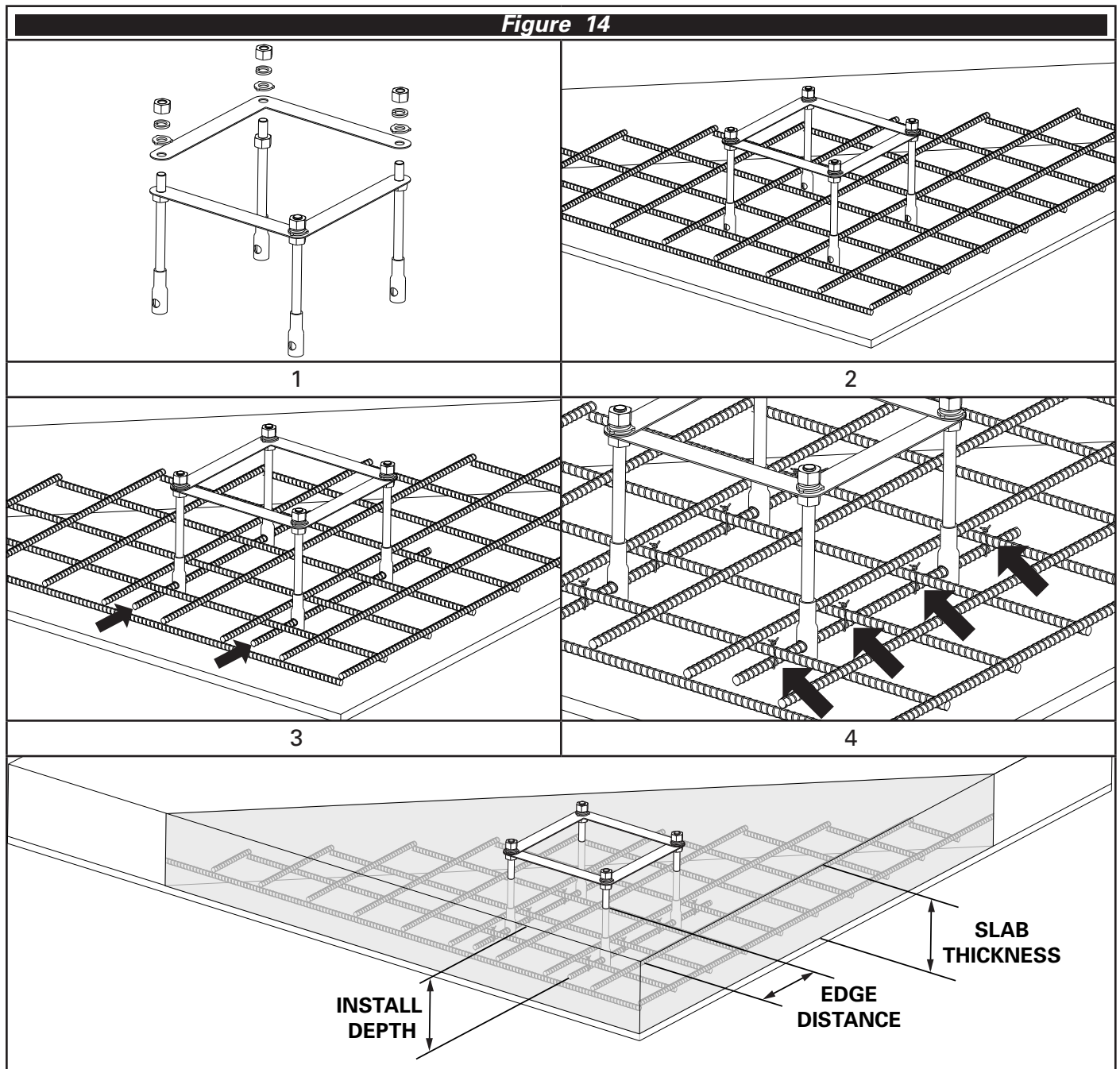

4.2.5 Concrete - DonutLink (DAVIT_BASE09)

⚠ The below instruction is for installation of DAVIT_BASE09 only.

SafetyLink's DonutLink M16 Concrete Stud (CON-M16X200-DONUT) are to be installed with chemical adhesive (CON-CHEM-FISV.300).

⚠ Minimum 20MPa uncracked concrete slab (consult SafetyLink for installation with cracked concrete)

⚠ Minimum 200mm slab thickness

⚠ Minimum slab edge distance 200mm

⚠ Embedded Depth 140mm

1 Mark the location for the hole and drill an $\varnothing 18\text{mm}$ hole to a depth of 140mm. Clean the hole, ensuring it is free of moisture and dust and inject the adhesive into the hole as per the manufacturer's instruction.

2 Insert the stud to full depth, a minimum of 45mm of the stud should remain above the surface. Wipe away any adhesive expelled from the hole.

⚠ Ensure enough adhesive was used, the adhesive should finish flush with the concrete.

3 Install the DAVIT_BASE09 with the DONUTLINK, nuts and spring washers. Tighten to 70Nm.

4 Any galvanised floor mounted base may be installed on DAVIT_BASE09 with the supplied fasteners.

The DonutLink can be proof loaded with the Pull Test Adaptor (DONUTLINK-ADP) and a Hydrajaws portable tension tester, see Section 4.2.8.

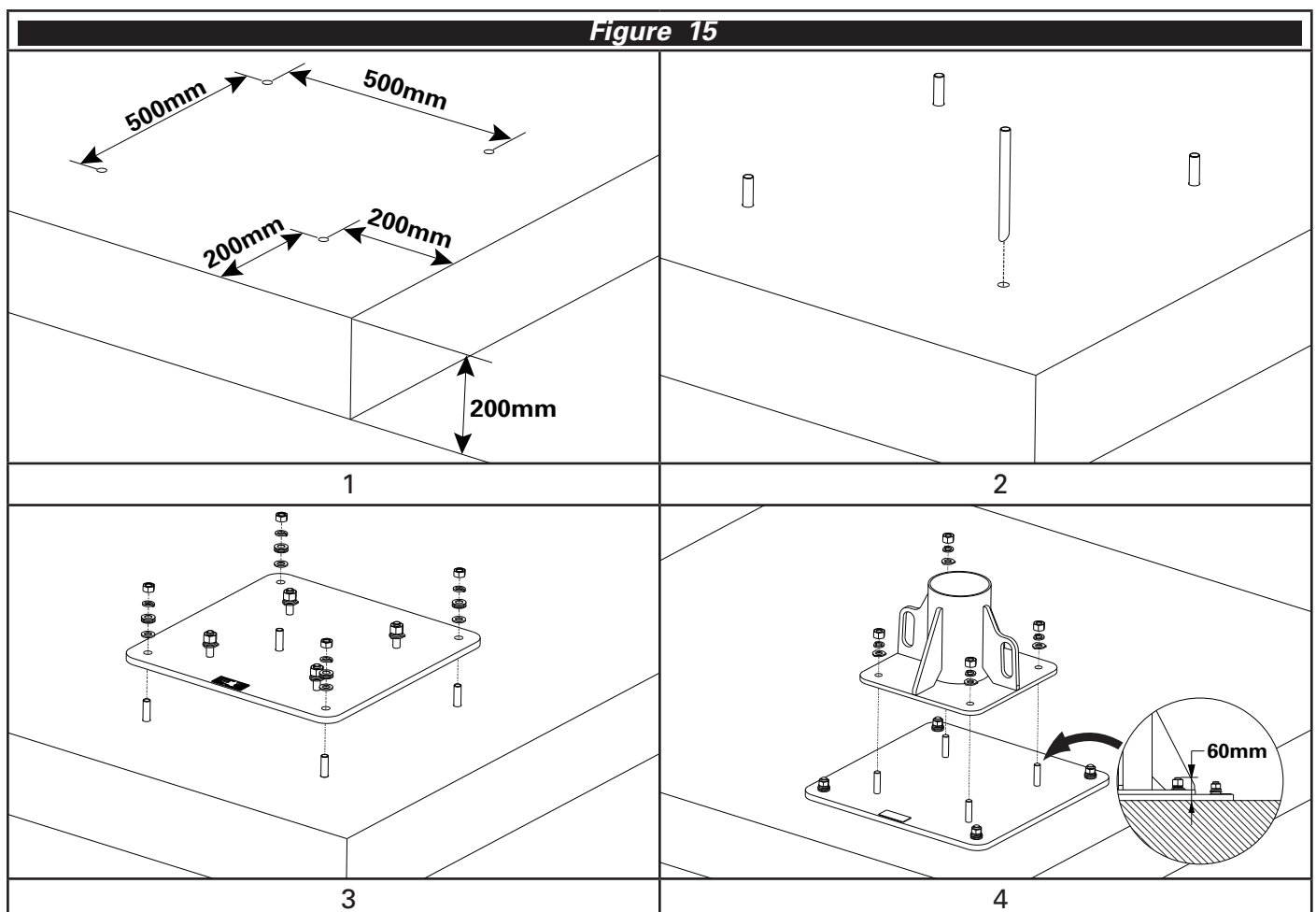

4.2.6 Base Installation (Galvanised)

- 1 Consult a structural engineer for the load cases in Section 3.2.
- 2 Set out davit bases according to Section 3.1.
- 3 Install the base with four fasteners using one of the fastener methods in Sections 4.2.1, 4.2.2 or 4.2.3. Tighten to 70Nm.

- ⚠ **The base shall be level to within 2 degrees.**
- ⚠ **Base label shall be marked with all appropriate booms.**
- ⚠ **DAVIT_BASE01, DAVIT_BASE02.01 and DAVIT_BASE08 (galvanised bases) are not suitable to be buried in soil.**
- ⚠ **Only stainless steel bases are suitable for being buried soil, see section 4.2.7.**

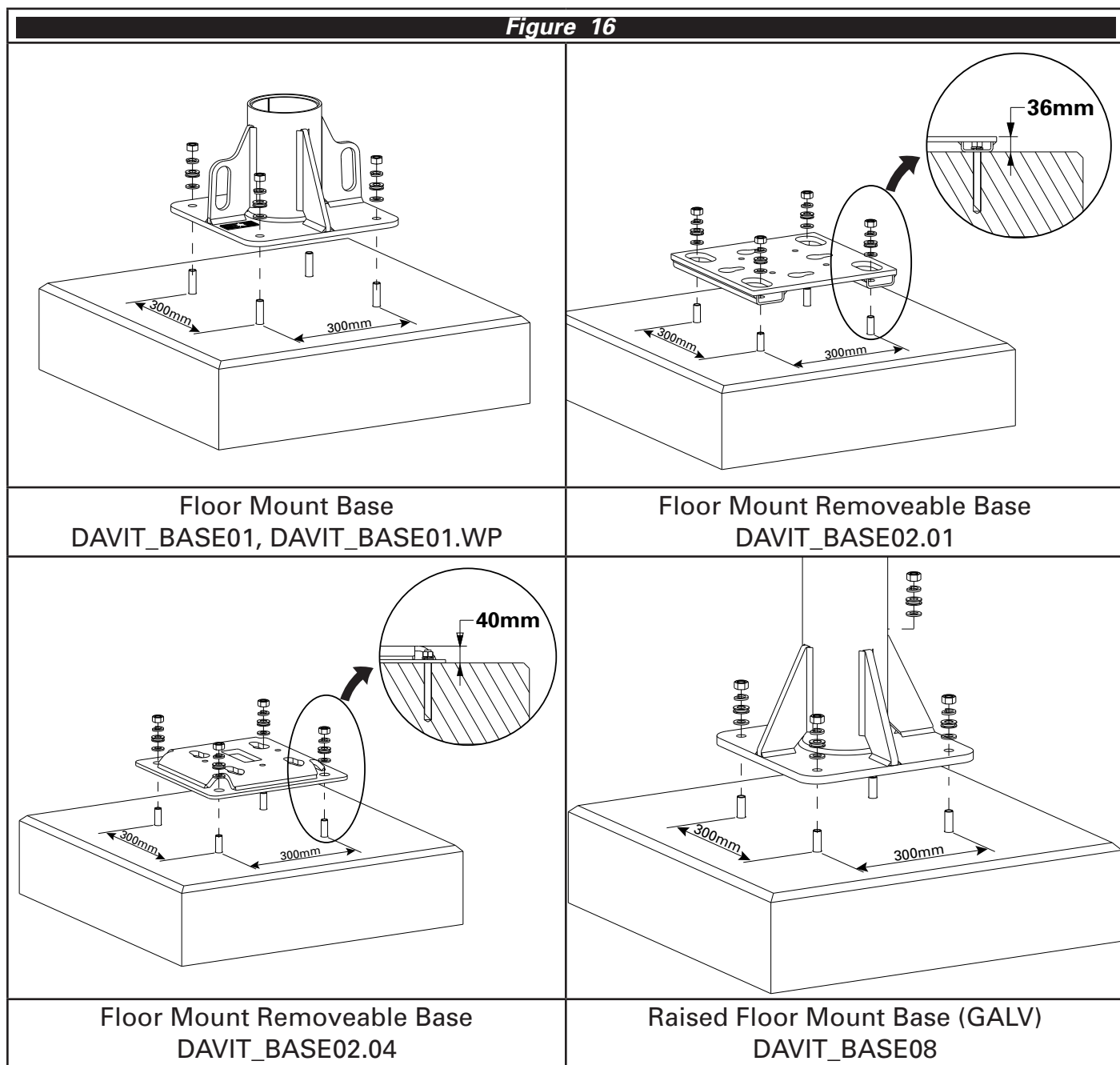

4.2.7 Planter Base Installation (Stainless steel)

- 1 Consult a structural engineer for the load cases in Section 3.2.
- 2 Set out davit bases according to Section 3.1.
- 3 Install the base with four fasteners using one of the fastener methods in Sections 4.2.1, 4.2.2 or 4.2.3. Tighten to 70Nm.
- 4 Where davit base (DAVIT_BASE07) is to be buried in soil, it is recommended that the soil level is at least 100mm below the top of the base to ensure the anchor points are free to use and to prevent debris from falling into the socket.

⚠ The base shall be level to within 2 degrees.

⚠ Base label shall be marked with all appropriate booms.

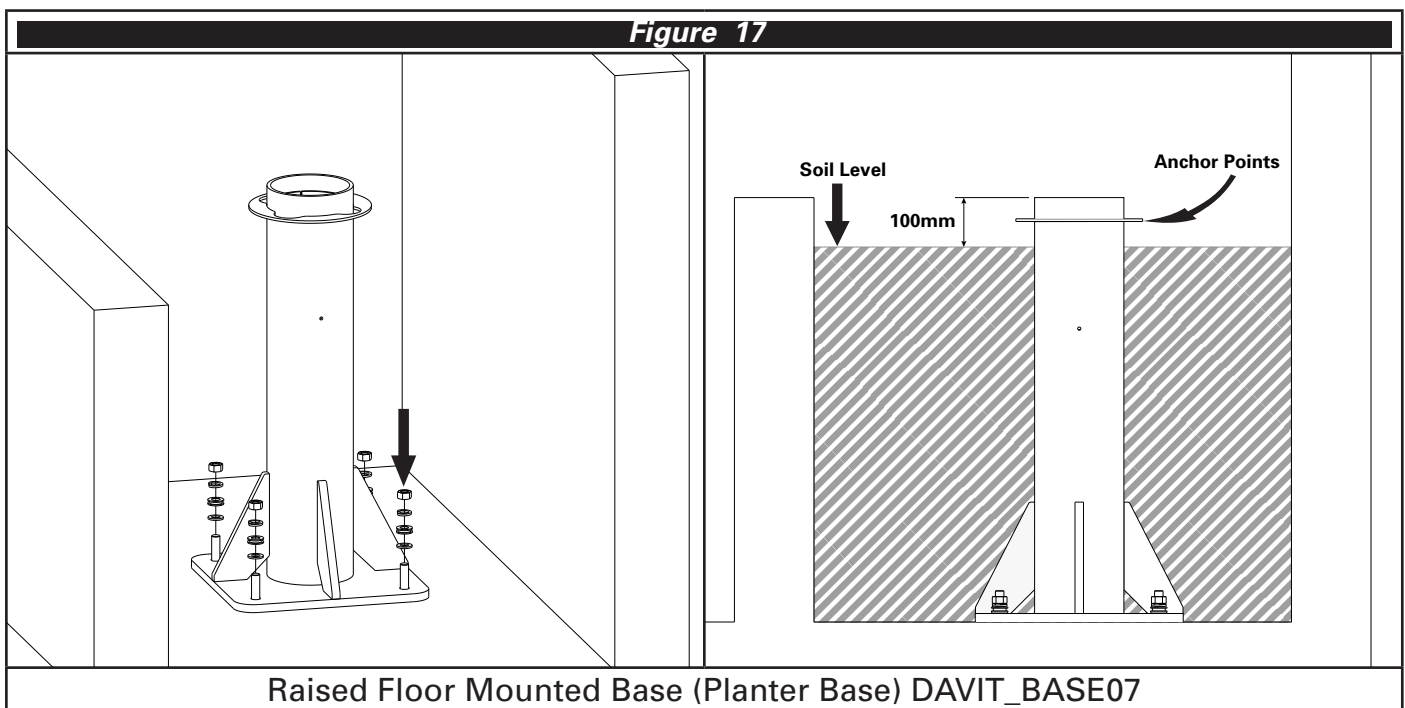

4.2.8 Proof Loading Standard Floor Mounted Bases

As required by AS/NZS1891.4, proof loading of all chemical and mechanical fixings is required after installation and at each annual inspection.

- 1 Install the DonutLink pull testing tool (DONUTLINK-ADP) onto a portable tension tester.
- 2 Position the DonutLink pull testing tool around the DonutLink washer.
- 3 Load the anchorage to the loads specified for each base type. Check that the anchorage is secure and holds the load.

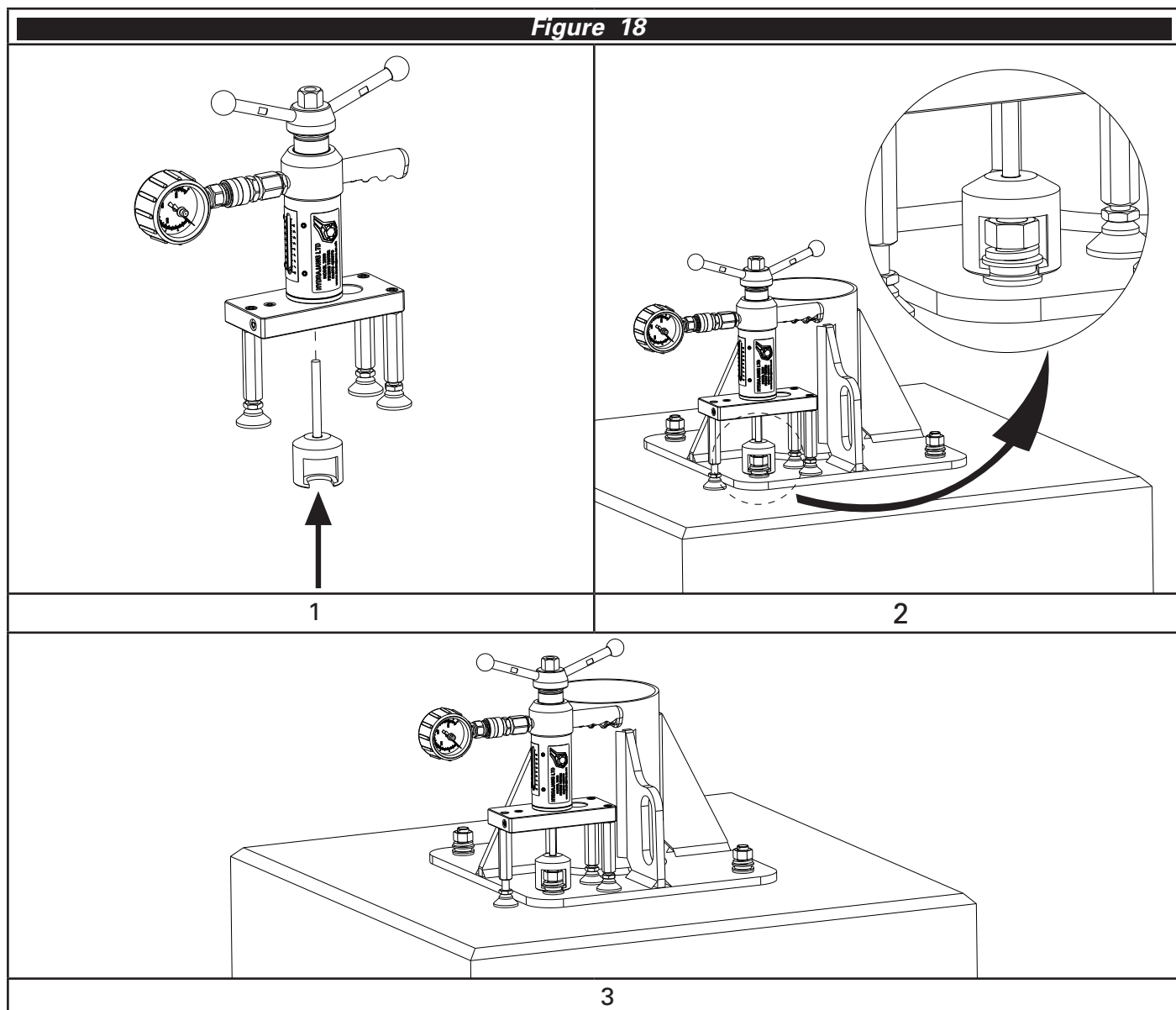

The below loads in Figure 19 are to be applied to each bolt and held for 30 seconds.

⚠ Proof loading is only required for chemical and mechanical fixed bases as per AS/NZS1891.4.

Figure 19

BOOM	DAVIT_BOOM22.BL	DAVIT_BOOM16.BL	DAVIT_BOOM10.BL
PROOF LOAD	23kN	16kN	9.5kN
DAVIT_BASE09	14kN	10kN	7.5kN

4.2.9 Installation of Planter Base Proof Loading Kit

As required by AS/NZS1891.4, proof loading of all chemical and mechanical fixings is required after installation and at each annual inspection. Where a davit base and its anchorages are buried within soil, SafetyLink recommends the use of the additional proof loading kit (DAVIT_BASE07.PROOF).

⚠ Extra care should be taken to ensure that the studs are installed plumb.

⚠ The base and proof loading kit must be installed before the planter is filled with dirt.

- 1 Install the M16 studs as per Section 4.2.1. Once the chemical has cured, install the PVC cap with the hole below the washer, spring washer and the nut and tighten to 70Nm. Ensure a minimum of 20mm is protruding above the nut.
- 2 Bolt the pipe support plate onto the base using the supplied fixings.
- 3 Glue the PVC pipe into the bottom cap using a PVC solvent cement.
- 4 The top of the pipe may be cut down to the desired finish height. Push the top caps on.

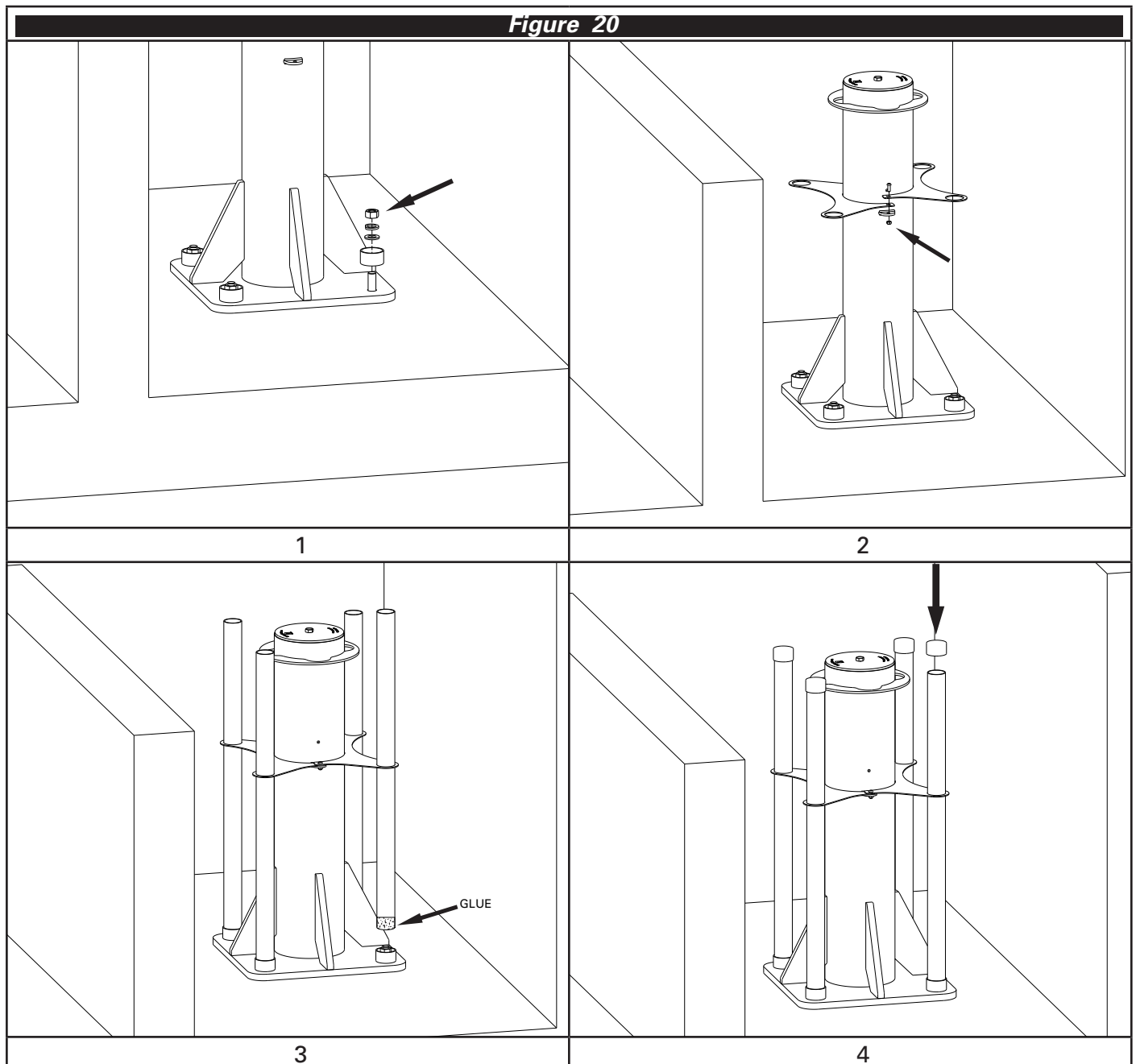

4.2.10 Proof Loading of Planter Bases

The below loads in Figure 21 are to be applied to each bolt and held for 30 seconds.

⚠ *Proof loading is only required for chemical and mechanical fixed bases as per AS/NZS1891.4.*

Figure 21			
BOOM	DAVIT_BOOM22.BL	DAVIT_BOOM16.BL	DAVIT_BOOM10.BL
PROOF LOAD	23kN	16kN	9.5kN

- 1 Remove the PVC cap and thread the tool DAVIT_BASE07.TOOL onto the end of the stud.
- 2 Attach the other end of the tool to a portable tension tester and apply the loads shown in Figure 21. Plywood or steel plating may need to be placed into the garden bed to rest the tension tester on.

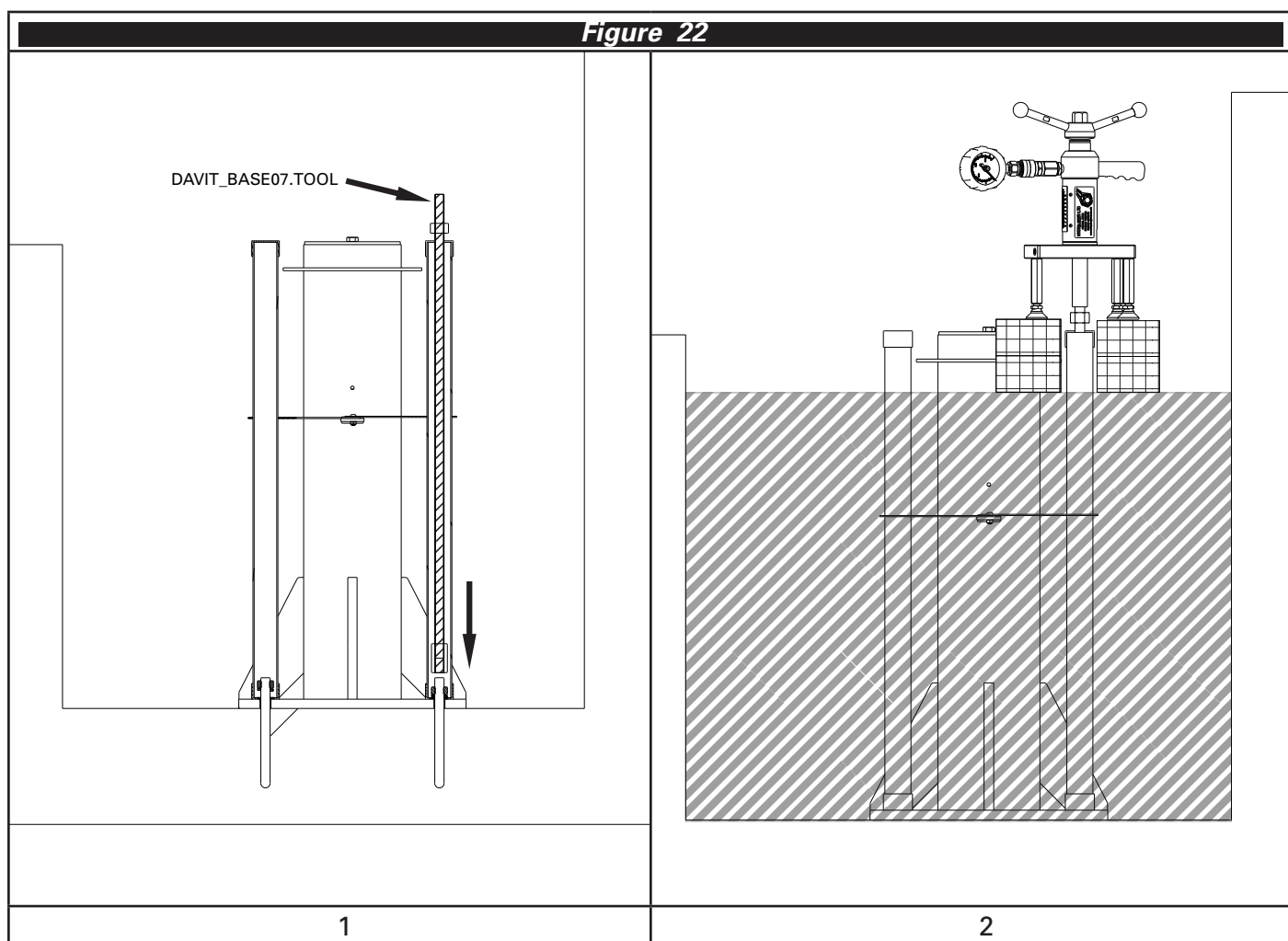

4.3 Removeable Base Sleeve

- 1 Ensure the fixed part of the removeable base has been installed as per Section 4.2.6.
- 2 Lower the removeable base sleeve onto the base plate, aligning the bolts with the profiled slots on the base plate.
- 3 Slide the base sleeve sideways until the locking pin keys into the base plate.
- 4 Ensure that the locking pin has engaged completely by attempting to slide the base sleeve back and forth. This will confirm that the removeable base sleeve is fixed in position.

⚠ Ensure the base is secured in the slots and the locking pin is engaged correctly. Failure to do so may result in serious injury or death.

⚠ Ensure that there are no obstructions to the slot holes (pebbles, dirt etc).

Figure 23

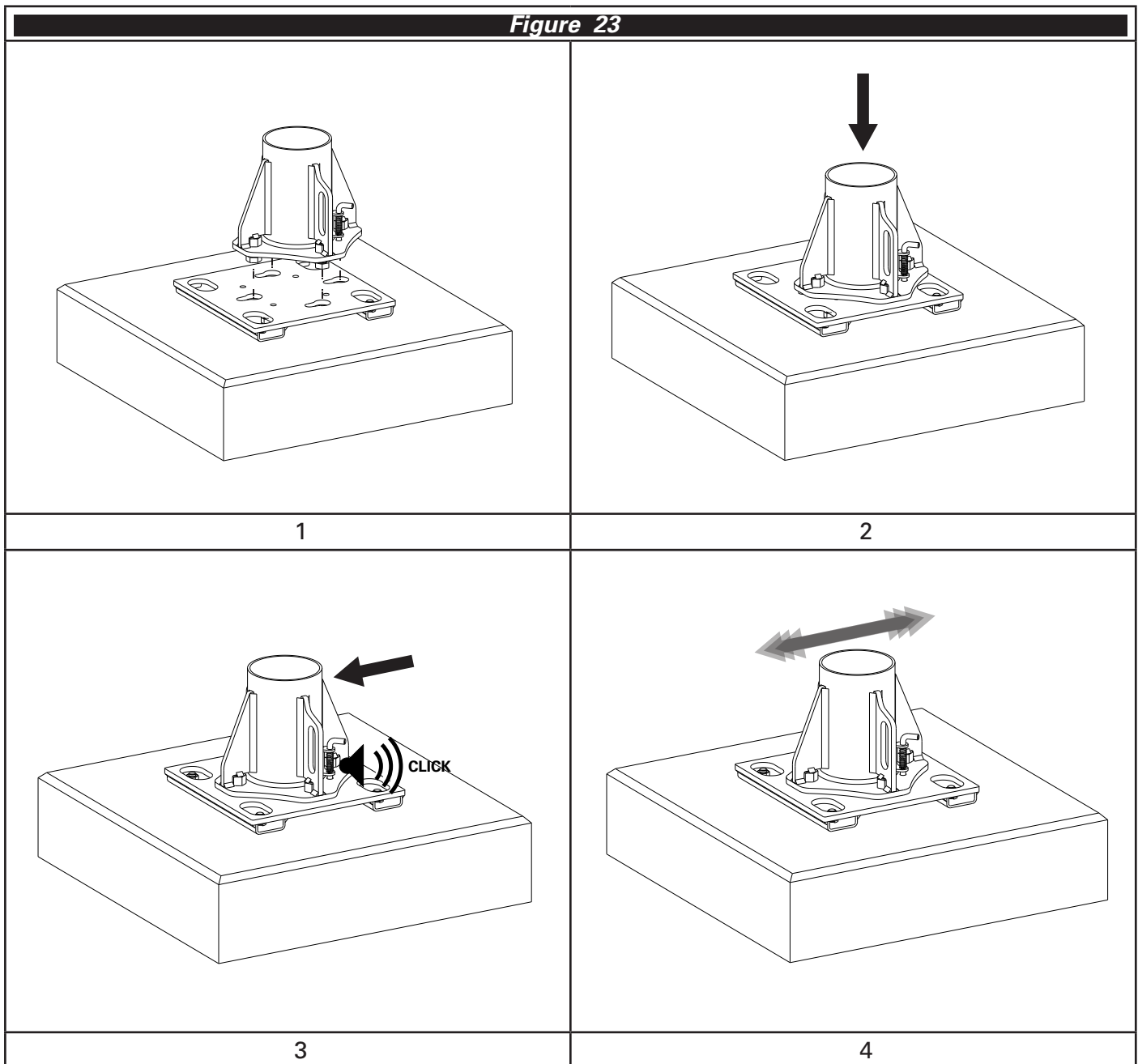

4.4 Wall Mounted Bases

4.4.1 Concrete - DonutLink (Wall Mounted Bases)

SafetyLink's DonutLink M16 Concrete Stud (CON-M16X200-DONUT) are to be installed with chemical adhesive (CON-CHEM-FISV.300).

- 1 Mark the location for the holes and drill an Ø18mm hole to the depth specified in the below table (Figure 24). Clean the hole, ensuring it is free of moisture and dust and inject the adhesive into the hole as per the manufacturer's instruction.
- 2 Insert the stud to full depth, a minimum of 45mm of the stud should remain above the surface. Wipe away any adhesive expelled from the hole.

⚠ This method is suitable for CON.CHEM.FISV.300. Other adhesives or products may require different depths or edge distances. Consult the manufacturer's instructions for details.

⚠ Minimum side wall edge distance 850mm.

⚠ Ensure enough adhesive was used, the adhesive should finish flush with the concrete.

The below table outlines the minimum requirements for installation depending on which size Davit boom will be used on the system.

Figure 24							
Product Code	Hole Diameter (mm)	32MPa			40MPa+		
		Minimum top Edge Distance (mm)	Minimum Slab Thickness (mm)	Minimum Hole Depth (mm)	Minimum top Edge Distance (mm)	Minimum Slab Thickness (mm)	Minimum Hole Depth (mm)
DAVIT_BOOM10.BL	18	150	130	90	150	130	90
DAVIT_BOOM16.BL	18	200	150	105	200	150	100
DAVIT_BOOM22.BL	18	250	200	145	250	180	140

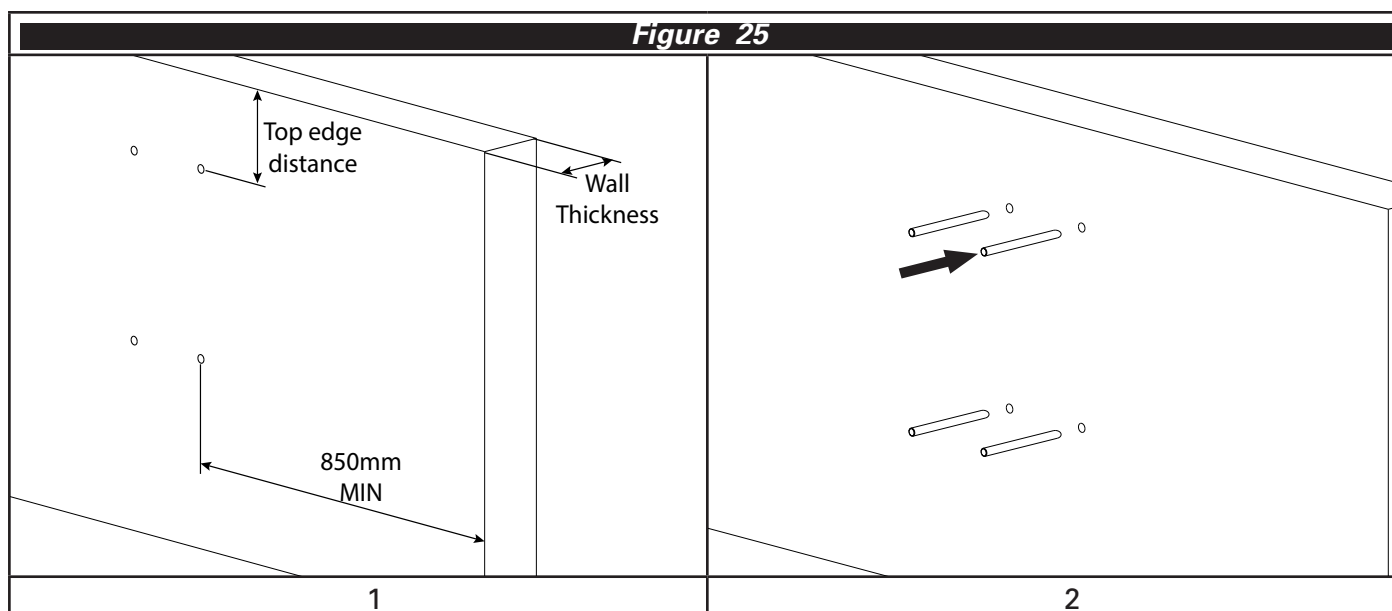

4.4.2 Base Installation

- 1 Consult a structural engineer for each of the relevant load cases in Section 3.2.
- 2 Set out davit bases according to Section 3.1.
- 3 Install the base with four fasteners as per Section 4.1.2 or 4.4.1. Ensure that the base is installed in the correct orientation as portrayed in Figure 26.

⚠ The base shall be level to within 2 degrees.

⚠ Base label shall be marked with all appropriate booms.

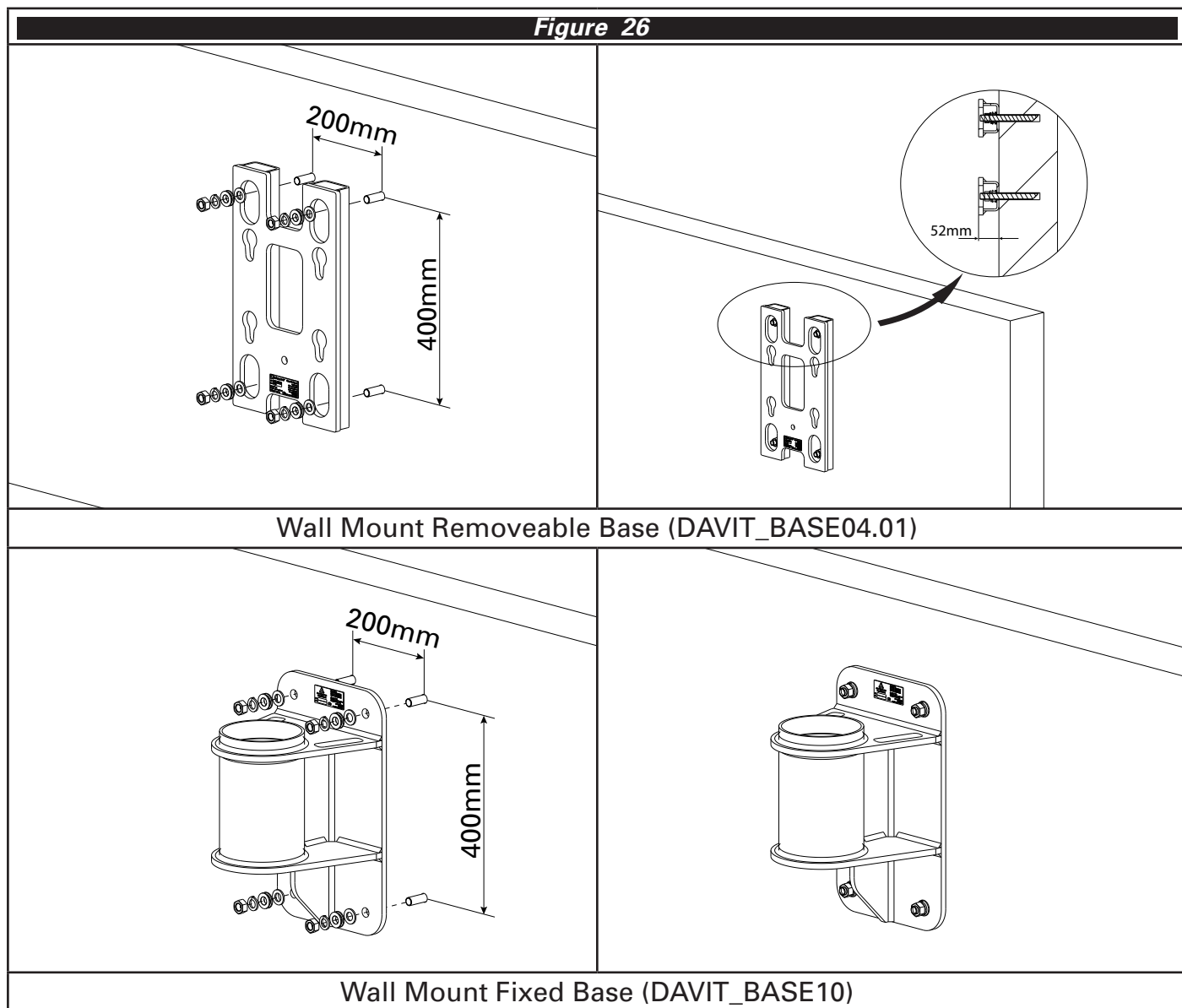

4.4.3 Proof Loading Wall Mounted Base

The below loads in Figure 27 are to be applied to each bolt and held for 30 seconds.

⚠ Proof loading is only required for chemical and mechanical fixed bases as per AS/NZS1891.4.

Figure 27

BOOM	DAVIT_BOOM22.BL	DAVIT_BOOM16.BL	DAVIT_BOOM10.BL
PROOF LOAD	21.65kN	16.35kN	11kN

4.5 Wall Mounted Removeable Base Sleeve

- 1 Ensure the fixed part of the removeable base has been installed as per Section 4.4.
- 2 Position the removeable base sleeve onto the base plate, aligning the bolts with the profiled slots on the base plate.
- 3 Lower the base sleeve downwards until the locking pin keys into the base plate.
- 4 Ensure that the locking pin has engaged completely by attempting to lift the base sleeve up and down. This will confirm that the removeable base sleeve is fixed in position.

! *Ensure the base is secured in the slots and the locking pin is engaged correctly. Failure to do so may result in serious injury or death.*

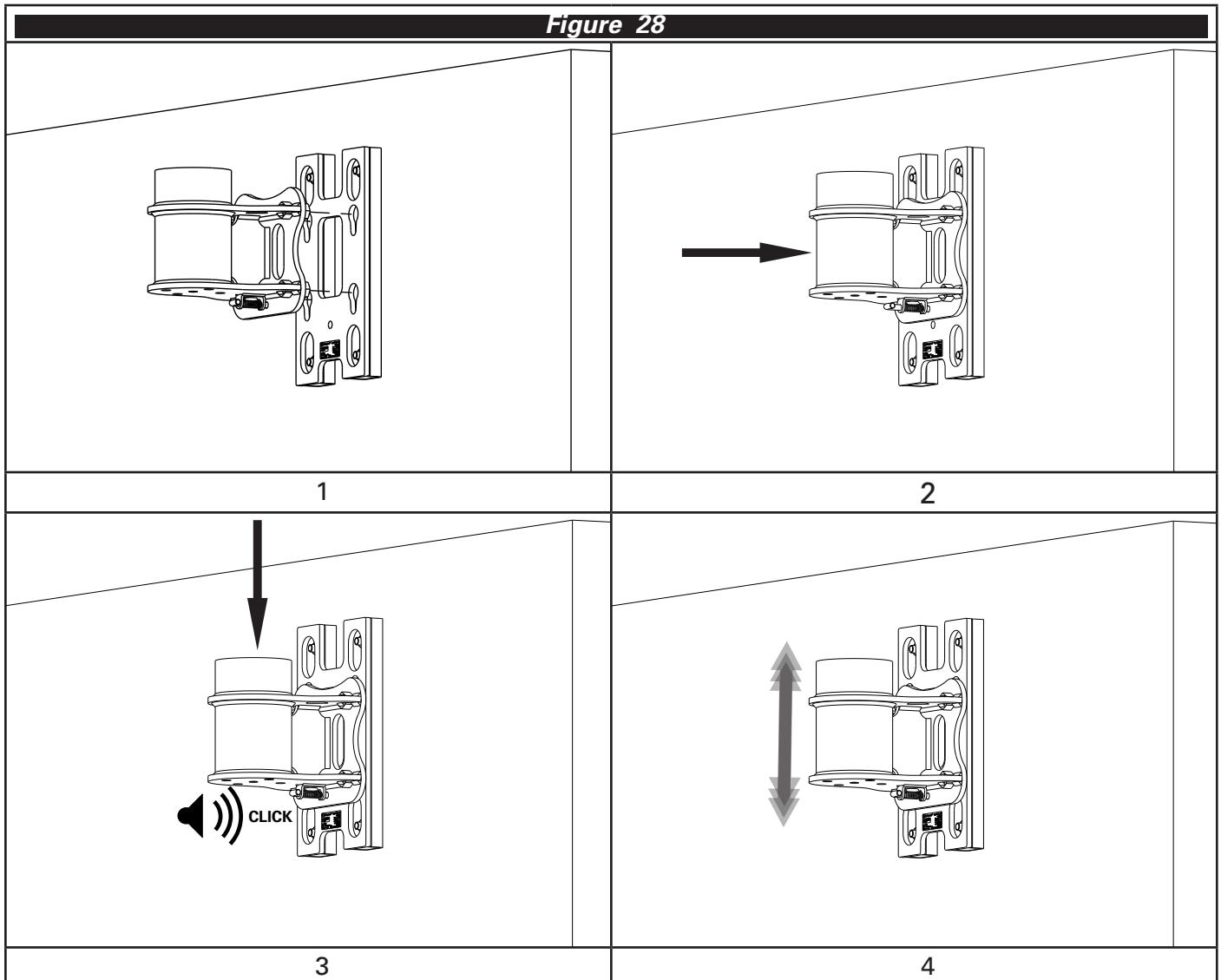

4.6 Base Cap

- 1 Ensure the bolt is loose and lower into the top of the base.
- 2 Tighten the bolt until the base cap is secure and creating a seal.

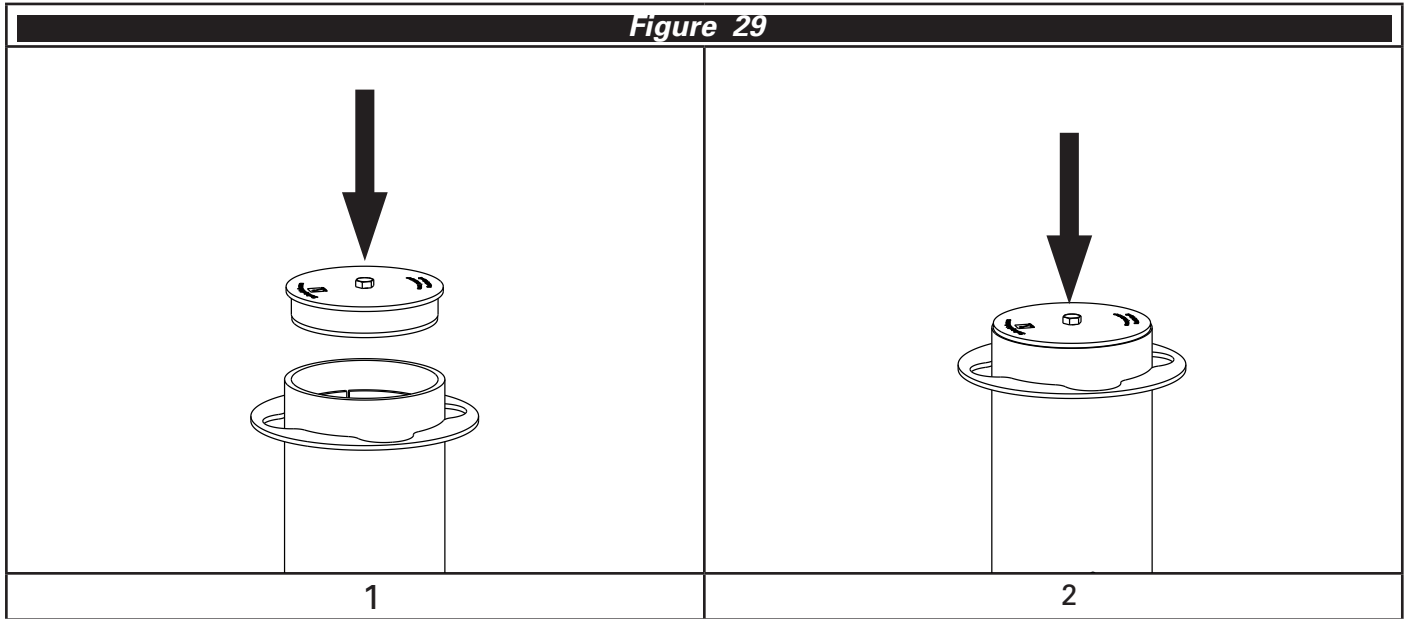

4.7 Mast and Boom Assembly

⚠ *If a removeable base is used, ensure that the sleeve is correctly installed and the pin is in the locked position as per section 4.3 & 4.5.*

1 Carefully lower the mast into the davit base.

⚠ *Where there is a risk of dropping the mast over the edge of the building, a lanyard shall be attached from the mast to the davit base.*

2 The boom should be positioned so that the tilt pin keys into the slot in the mast.

3 The boom can then be lifted into position and the 20mm detent locking pin must be installed.

⚠ *Where there is a risk of dropping the boom over the edge of the building, a lanyard shall be attached from the boom to the davit base.*

4 Finally, check over all pins to ensure they are properly engaged.

Figure 30

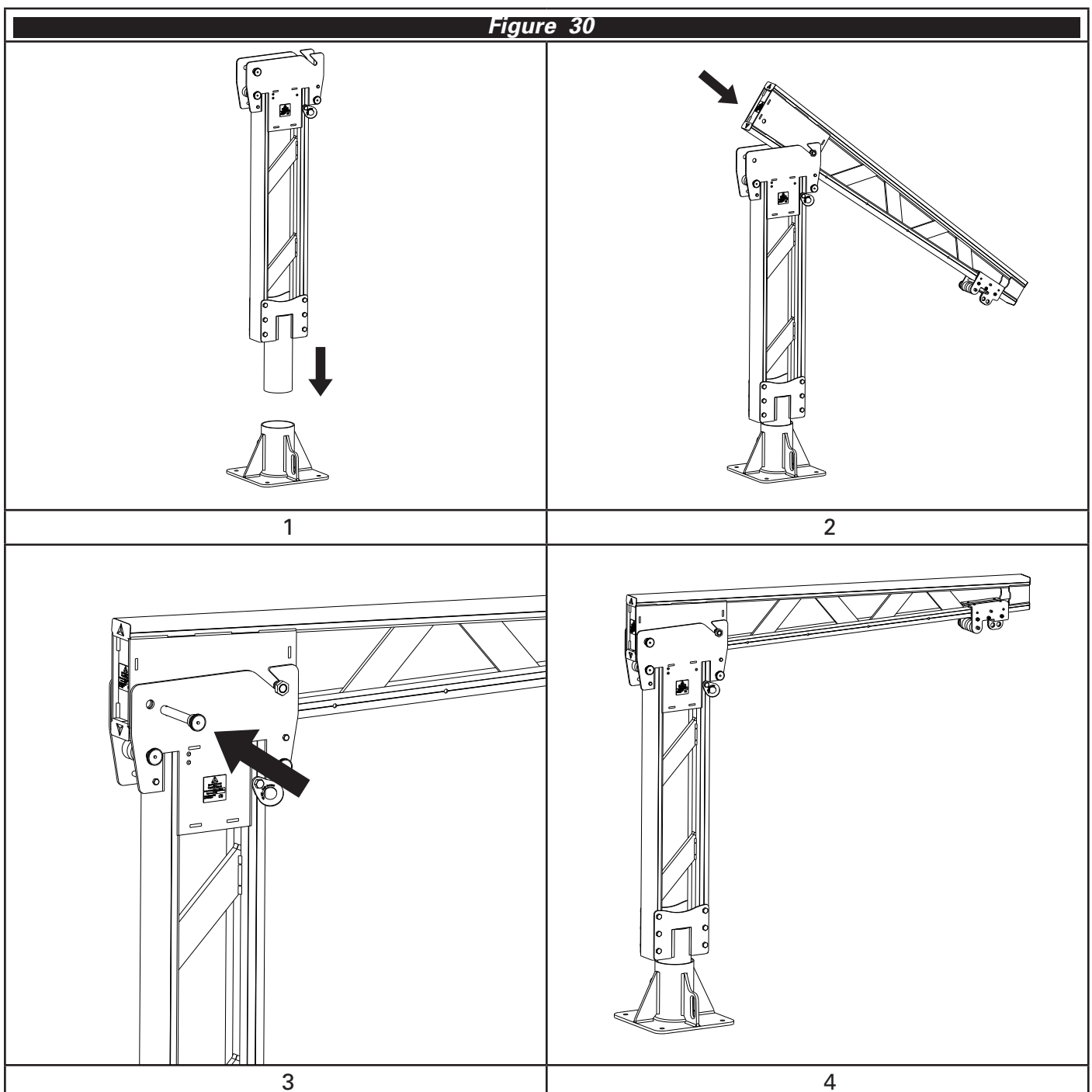

5 Limitations of Use

5.1 Fall Clearance

When planning your fall protection system, it is important to accurately assess all components of your system in order to avoid injury. Figure 31 provides guidance on how to calculate fall clearance. In Figure 31, (D) represents deflection of the anchor (0.2m), (E) represents energy absorber deployment and estimated D-ring slide of the harness (Refer the manufacturer's information), (SF) represents the recommended safety factor of 1m, (FC) represents the total allowable fall clearance. For safe use, FC shall always be greater than $D + E + SF$.

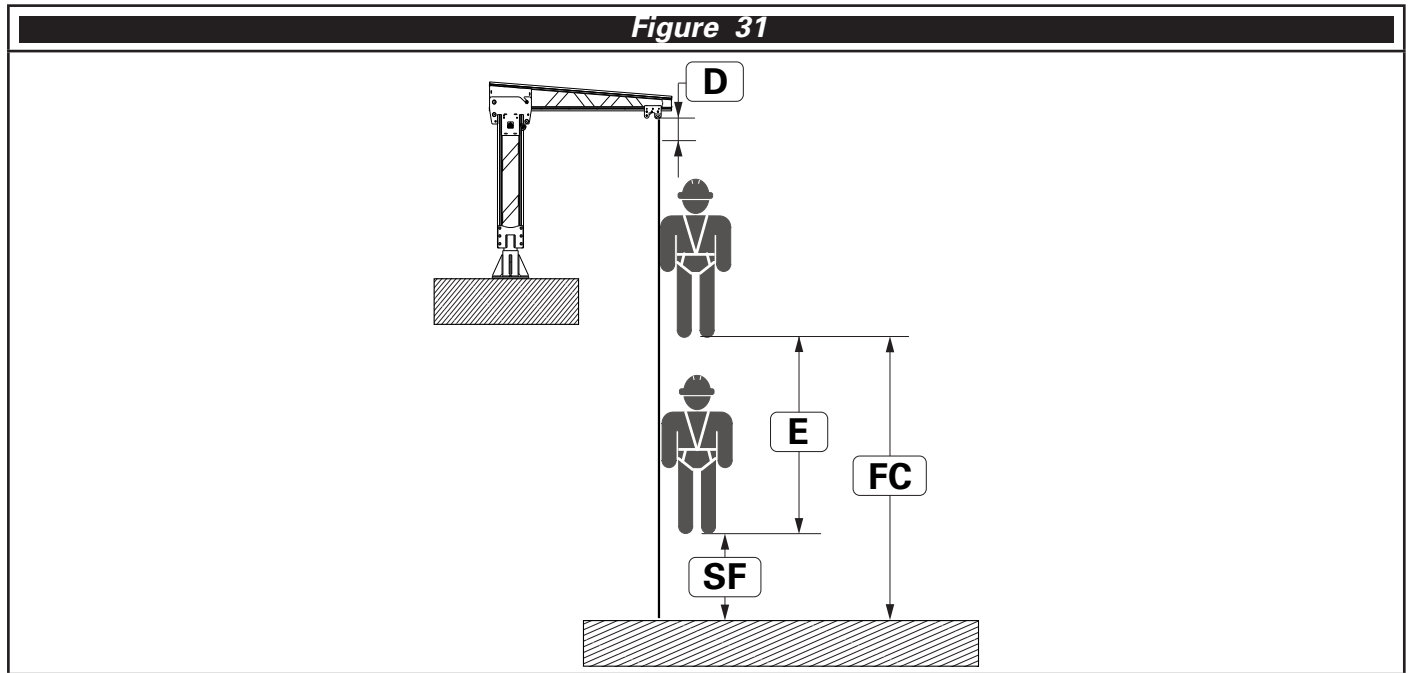

5.2 Swing Fall

Working off centre of a temporary anchor may cause a swing fall. See Figure 32. Fall protection systems shall be setup in such a way to limit swing fall.

⚠ The force of striking an object during a swing fall may result in serious injury or death.

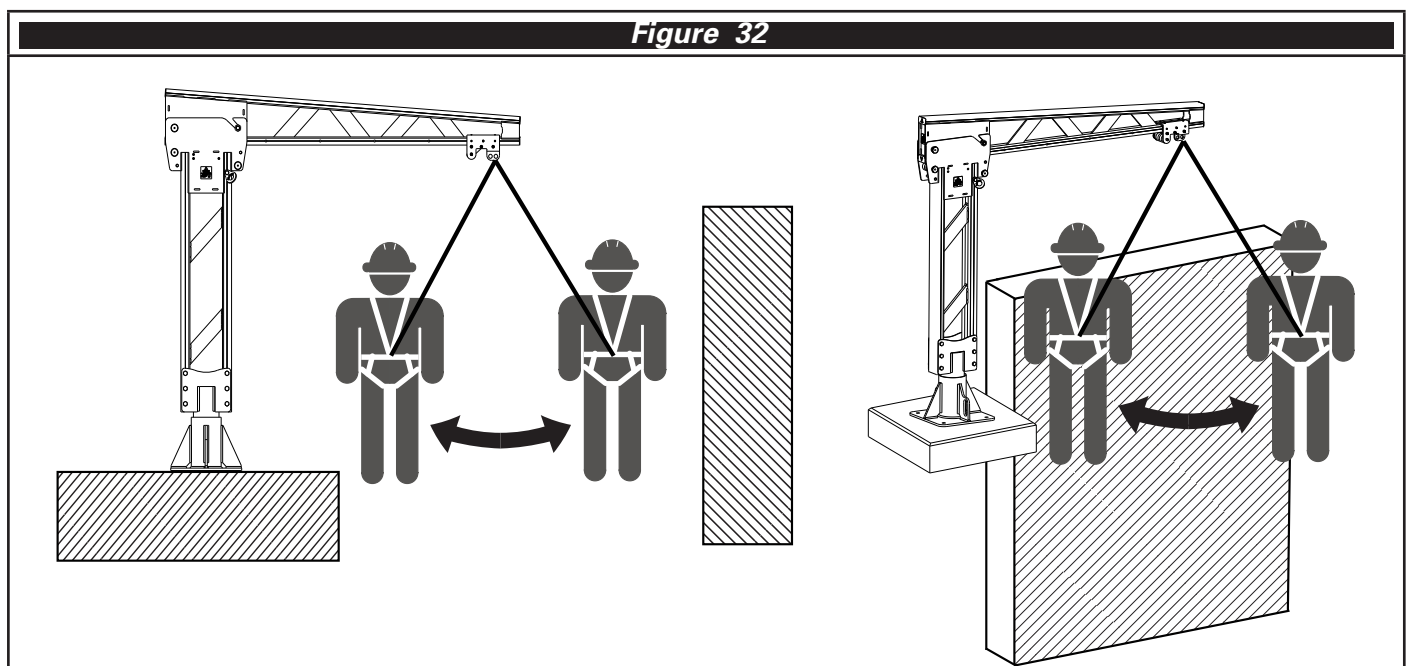

5.3 Area of Use

Working outside of the area of use of a temporary anchor may cause the anchor to malfunction.

⚠ Always work within the area highlighted in Figure 4.

5.4 Hazards

Use of this equipment in the presence of hazards may cause damage to the equipment and/or result in the function of the equipment being impeded. These hazards include but are not limited to; extreme temperature, sharp edges, chemical reagents, electrical conductivity, abrasion, cutting, climatic exposure and rotating or moving machinery.

5.5 Training

It is essential that all users are trained in the proper inspection, setup and use of this equipment. It's the responsibility of the user to ensure they are trained in the correct use of this equipment and understand the limitations of its use.

⚠ Incorrect use of this equipment may result in serious injury or death.

5.6 Rescue

It is the responsibility of the user of this equipment and their employer to have a suitable rescue plan and the ability to implement it at any time during setup and use of this equipment.

5.7 Materials Handling

The davit may be used to lift materials. Davits used for material lifting purposes shall not be used for supporting a user. The following table provides the maximum loads allowable on the different davit booms.

⚠ Once a davit has been used for materials handling, it shall not be used as part of a fall protection system.

Figure 33			
BOOM	DAVIT_BOOM22.BL	DAVIT_BOOM16.BL	DAVIT_BOOM10.BL
LOAD	300kg	450kg	500kg

6 Connections

6.1 Making Connection

Only make compatible connections. Always ensure connectors close and lock correctly before use. Below and Figure 35 are examples of unsuitable connections;

- 1 To an anchor or D-ring which has another connector attached.
- 2 In a position that will apply load to the gate mechanism.
- 3 By passing the connection through the attachment.
- 4 Connecting a connector to another connector.
- 5 Around a structure and back to the lifeline.
- 6 To an attachment that will limit the function of the gate.
- 7 To a location that will not load the connector as designed.

6.2 Compatibility of Connections

Connection made to and with this equipment shall be compatible. Connector shall be compatible shape, size and equivalent rating in order to ensure a compatible connection is made. Incompatible connections may cause loading of the gate mechanism leading to unintentional disengagement. See Figure 34. Connectors shall be compliant with EN362 and auto closing and locking.

⚠ Making incompatible or unsuitable connection may result in unintentional disengagement of the connector resulting in serious injury or death.

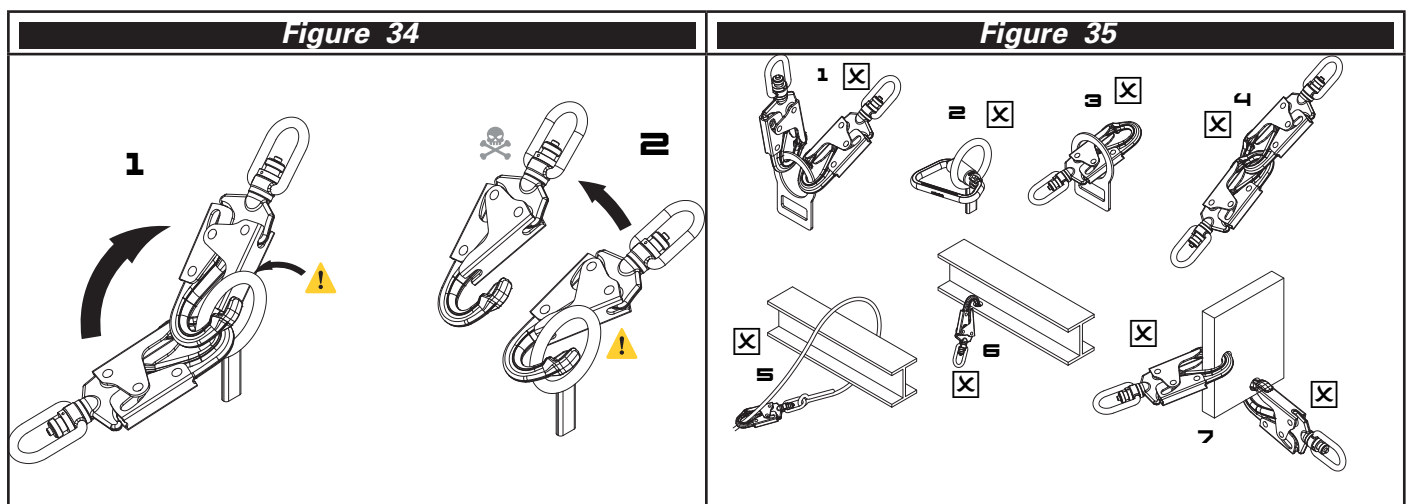

7 Use

7.1 Planning

Before starting work, plan your working at heights and rescue systems by accounting for all hazards present in the work place and allowing for the available fall clearance. Ensure all users are fit, healthy and capable of safely operating this equipment as well as implementing the rescue plan.

⚠ During use, always allow for the required fall clearance, swing fall and hazards present in the work place.

7.2 FastFit Davit

⚠ All components of the davit system are to be inspected prior to use.

- 1 Slide the shuttle out to the required position. The locking pin may be used to lock the location of the user, however it is not a requirement unless the pulleys are being utilised.
- 2 If the ropes are to be run over the pulleys, the shuttle must be locked in position with respect to the boom using the detent locking pin. The pulley pin can be removed to allow the pulleys to swing out of way. The ropes can be positioned on the pulleys and the pin reinserted.
- 3 The anchor points located on the mast of the davit are rated to 15kN and may be used to connect backup ropes to. The anchor points on the base are rated to 21kN.
- 4 The davit can be pivoted 360° around the base.

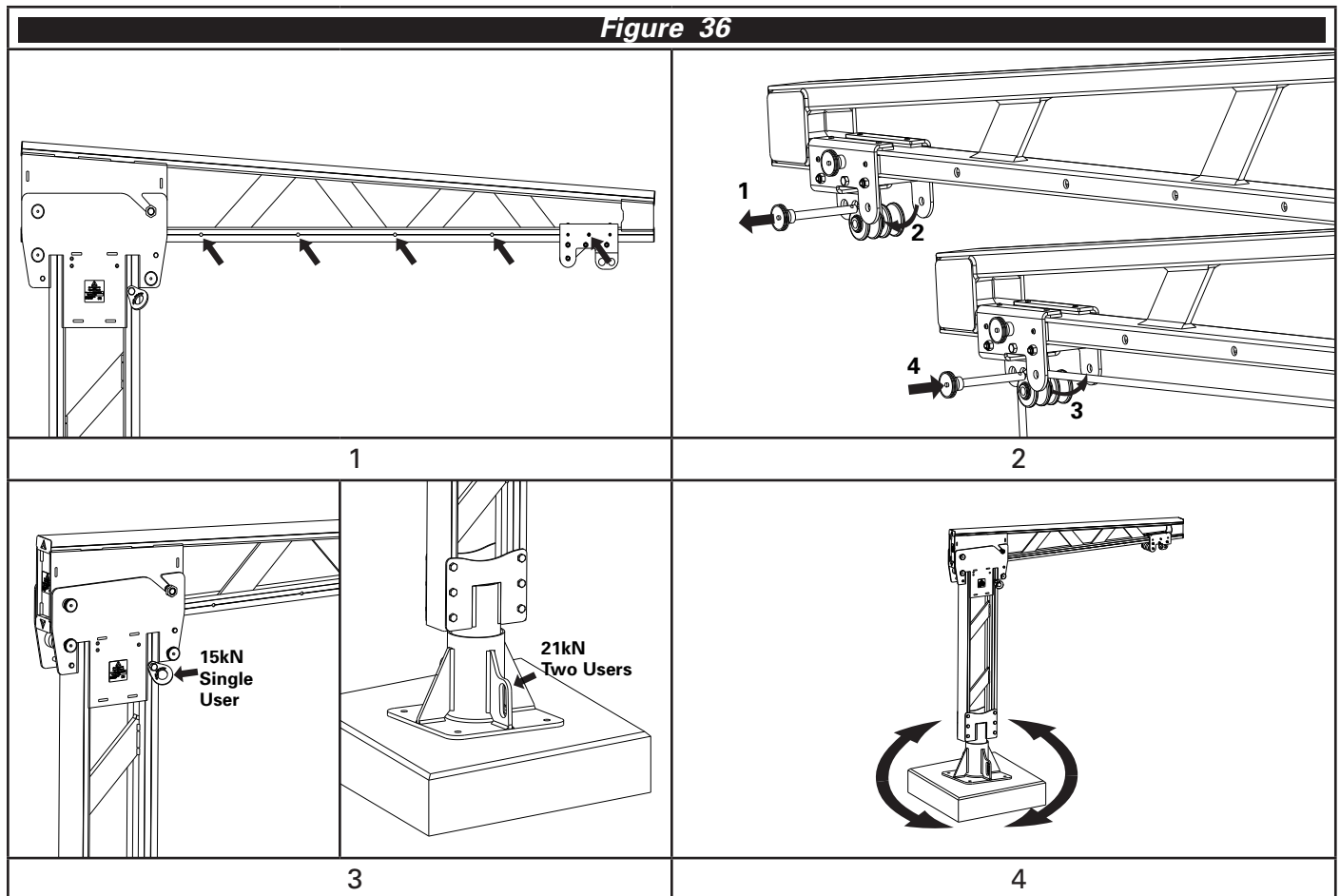

⚠ The shuttle is for a single user. Do not attach multiple users to the shuttle.

⚠ Do not attach to any other point on the FastFit Davit.

8 Storage, Transport and Maintenance

8.1 Storage and Transport

This equipment shall be stored and transported in a cool, dry environment, away from any hazards and out of direct sunlight.

8.2 Maintenance

8.2.1 The FastFit Davit system is serviceable only by trained and authorised installers. Contact SafetyLink to find your nearest available installer. The service interval will be determined by the condition in which it is used. Harsher conditions will require more frequent servicing. The equipment may remain in service until it fails an inspection or is involved in a fall.

⚠ Do not attempt to modify or disassemble this product.

8.3 Cleaning

The FastFit Davit temporary anchor may be cleaned by the end user periodically to increase service life. After cleaning, the product shall undergo the pre-use inspection.

Clean with a rag and warm water to remove dirt and grit. A mild detergent may be used to remove grease or oils from the product.

⚠ Do not store this product when wet. Allow the product to dry and conduct a pre-use inspection prior to return the item to service.

9 Inspection

9.1 Before and After Use

The FastFit Davit temporary anchor shall be inspected before and after each use by the user.

9.2 Competent Person

A competent person shall inspect the system at least every 2 years. Systems installed in harsher conditions will require more frequent inspection. Installations in marine, coastal or other extreme corrosive environments should be inspected at least every 12 months.

9.3 Procedure

9.3.1 Base - Inspect the base for damage, deformation, or debris that may affect the strength. Inspect the welds are free of cracks. Inspect the galvanised surface finish is intact. Ensure sleeve is free from debris. Check last date of inspection by competent person.

9.3.2 Mast and Boom - Inspect welds for corrosion, discolouration or damage. Inspect the holes for the locking pins are not elongating and do not allow the pin to be removed without pressing the release button. Ensure fasteners are tight and free from corrosion.

9.3.3 Shuttle - Inspect fasteners for tightness and ensure it freely moves along the boom.

9.3.4 Label - Inspect the system label is present and legible as per Figure 37.

9.3.5 Proof Load - For competent person inspections only, concrete fixings that do not extend through the concrete and are not cast in shall be proof loaded to 50% of the design load and held for 30 seconds.

INSPECTION RECORD			
Product Code		Date of Manufacture	
Serial or Batch No.		Date of Install	
Inspector		Date of Inspection	
PROCEDURE	INSPECTION	USER	COMPETENT PERSON
9.3.1	Base - Inspect the base for damage, deformation, or debris that may affect the strength. Inspect the welds are free of cracks. Inspect the galvanised surface finish is intact. Ensure sleeve is free from debris. Check last date of inspection by competent person.	<input type="checkbox"/>	<input type="checkbox"/>
	Comments:		
9.3.2	Mast and Boom - Inspect welds for corrosion, discolouration or damage. Inspect the holes for the locking pins are not elongating and do not allow the pin to be removed without pressing the release button. Ensure fasteners are tight and free from corrosion.	<input type="checkbox"/>	<input type="checkbox"/>
	Comments:		
9.3.3	Shuttle - Inspect fasteners for tightness and ensure it freely moves along the boom.	<input type="checkbox"/>	<input type="checkbox"/>
	Comments:		
9.3.4	Label - Inspect the system label is present and legible as per Figure 37.	<input type="checkbox"/>	<input type="checkbox"/>
	Comments:		
9.3.5	Proof Load - For competent person inspections only, concrete fixings that do not extend through the concrete and are not cast in shall be proof loaded to 50% of the design load and held for 30 seconds.	N/A	<input type="checkbox"/>
	Comments:		

Figure 37



SAFETYLINK FastFit Davit

Product Code:

Batch No.:

AS/NZS5532:2013
RATING:15kN



Mast and Boom Label



SAFETYLINK
FastFit Davit

PC:
BN:



Base Rating
 DAVIT_BOOM22.BL
 DAVIT_BOOM16.BL
 DAVIT_BOOM10.BL

Fastener Type
 Chemical / Mechanical
 Cast in / Thru Bolt

AS/NZS5532:2013
EN795:2012
Attachment points:21kN



SAFETYLINK
FastFit Davit



Attachment points:21kN

WARNING!
Ensure base is secured in the slots and the locking pin is engaged correctly. Failure to do so may result in serious injury or death.

Base Rating
 DAVIT_BOOM22.BL
 DAVIT_BOOM16.BL
 DAVIT_BOOM10.BL

Fastener Type
 Chemical / Mechanical
 Cast in / Thru Bolt

PC:
BN:

Fixed Base Label

WARNING!
Ensure base is secured in the slots and the locking pin is engaged correctly. Failure to do so may result in serious injury or death.

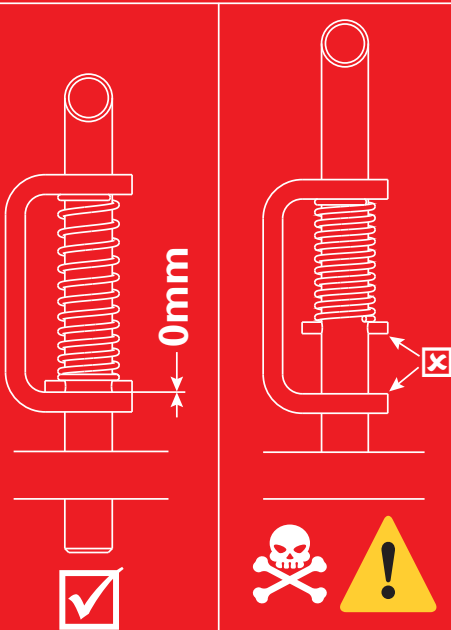

Removeable Base Sleeve Warning Label 1

Removeable Base Label



Removeable Base Sleeve Warning Label 2

Warranties

EXTRACT: SAFETYLINK PTY LTD STANDARD TERMS AND CONDITIONS

- 1.1 To the extent permitted by law all implied conditions, warranties and undertakings are expressly excluded.
- 1.2 Except as provided in this clause the Company shall not be liable for any loss or damage, whether direct or indirect (including consequential losses or damage) arising out of any breach of contract by the Company or any negligence of the Company, its employees or agents.
- 1.3 Should the Company be liable for a breach of a guarantee, condition or warranty implied by the Australian Consumer Law (not being a guarantee, condition or warranty implied by sections 51, 52 and 53 of that Law) then its liability for a breach of any such condition or warranty express or implied shall be limited, at its option, to any one or more of the following.
- A in case of Goods
- I the replacement of the Goods or the supply of equivalent Goods.
 - II the repair of the goods,
 - III the payment of the cost of replacing the Goods or acquiring equivalent Goods.
 - IV the payment of the cost of having the Goods repaired. Provided that any such Goods are returned to the Company by the Purchaser at the Purchaser's expense.
- B in the case of services
- I the supply of the services again,
 - II the payment of the cost of having the services supplied again.
- 1.4 The Company is not liable for the costs of recovery of the Goods from the field, loss of use of the Goods, loss of time, inconvenience, incidental or consequential loss or damage, nor for any other loss or damage other than as stated above, whether ordinary or exemplary, caused either directly or indirectly by use of the Goods.
- 1.5 The Company warrants that at the time of shipment, Products manufactured by it will be free from defects in material and workmanship. In the absence of a modified written warranty, the Company agrees to making good any such defects by repairing the same or at the Company's option by replacement, for a period of (1) one year from the date of shipment. This limited warranty applies provided that:
- a defects have arising solely from faulty materials or workmanship;
 - b the Products have not received maltreatment, inattention or interference;
 - c the Products have been installed in accordance with the Company's Installation Handbooks using only products supplied by the Company;
 - d accessories used with the Products are manufactured by or approved by the Company
 - e the Products are maintained in accordance with Australian Standard 1891.4 (section 9).
 - f you notify any claim under this warranty to SafetyLink in writing to the address below no later than 14 days after the event or occurrence concerning the produce giving rise to the claim and you pay all costs related to your claim.
- This warranty does not apply to any defects or other malfunctions caused to the Goods by accident, neglect, vandalism, misuse, alteration, modification or unusual physical, environment or electrical stress.
- Please note that the benefits to the purchaser (as a consumer) given by this warranty are in addition to your other rights and remedies under the Australian Consumer Law. Our goods come with guarantees that cannot be excluded under the Australian Consumer Law. You are entitled to a replacement or refund for a major failure and compensation for any other reasonably foreseeable loss or damage. You are also entitled to have the goods repaired or replaced if the goods fail to be of acceptable quality and the failure does not amount to a major failure.
- 1.6 If any goods are not manufactured by the Company, the guarantee of the manufacturer thereof shall be accepted by the Purchaser as the only express warranty given in respect of the goods.
- 1.7 Except as provided in this clause 11, all express and implied warranties, guarantees and conditions under statute or general law as the merchantability, description, quality, suitability or fitness of the Products for any purpose or as to design, assembly, installation, materials or workmanship or otherwise are hereby expressly excluded (to the extent to which they may be excluded by law).

PLEASE SEE SAFETYLINK PTY LTD FULL STANDARD TERMS OF CONDITIONS OF SALE FOR FURTHER REFERENCE.



SafetyLink Pty Ltd | ABN 83 081 777 371 | www.safetylink.com

Head Office: 54 Bonville Ave, Thornton, 2322, NSW, Australia

+64 2 4964 1068 | 1300 789 545

Asia-Pacific/The Americas | info@safetylink.com

Europe/Africa/Middle East | europe.sales@safetylink.com

Northern Europe | uk.sales@safetylink.com