

SafetyLink's ConcreteLink Cast In Cages are concrete studs set at the correct spacing for different products. The cages are to be installed prior to the concrete being poured.

Tested to AS/NZ5532 when tested with SafetyLink Anchors.

CAST-IN CAGE FOR ROUND TUFF-POST 150mm

PRODUCT CODE: CON-CAST-TP150R_SS

Product Parts	Description	Qty
CON-CAST-TP150R_SS.01	Cast In Cage Stud M12 for 150mm Round Tuff Post	2
CON-CAST-TP150R.01	Casting Jig for 150mm Round Tuff Post	1
CON-CAST.02	Reo Bar: 12mm x 595mm	1
WASHER M12_Spring_316	Washer: M12 Spring	2
WASHER M12_316	Washer: M12	2
NUT M12_316	Nut: M12	4



CAST-IN CAGE FOR ROUND TUFF-POST 300, 600 & 900mm

PRODUCT CODE: CON-CAST-TP300R_SS

Product Parts	Description	Qty
CON-CAST-TP300R_SS.01	Cast In Cage Stud M16 for 300mm Round Tuff Post	4
CON-CAST-TP300R.01	Casting Jig for 300mm Round Tuff Post	2
CON-CAST.02	Reo Bar: 12mm x 595mm	2
WASHER M16_Spring_316	Washer: M16 Spring	4
WASHER M16_316	Washer: M16	4
NUT M16_316	Nut: M16	8

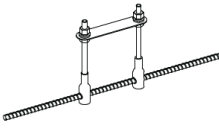
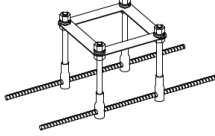
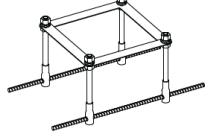

Cast In Cages's shall be installed at the depth, edge distance and slab thickness provided in the installation handbook (see Figure 2 from handbook below).

Figure 2			
			
	150mm Tuff Post	300, 600 & 900mm Round Tuff Post	Floor Mounted Davit Base
SS316	CON-CAST-TP150R_SS	CON-CAST-TP300R_SS	N/A
GALV	CON-CAST-TP150R_GAL	CON-CAST-TP300R_GAL	DAVIT_BASE05
Min Install Depth	100mm	110mm	140mm
Min Slab Thickness	150mm	150mm	200mm
Min Edge Distance	150mm	150mm	200mm

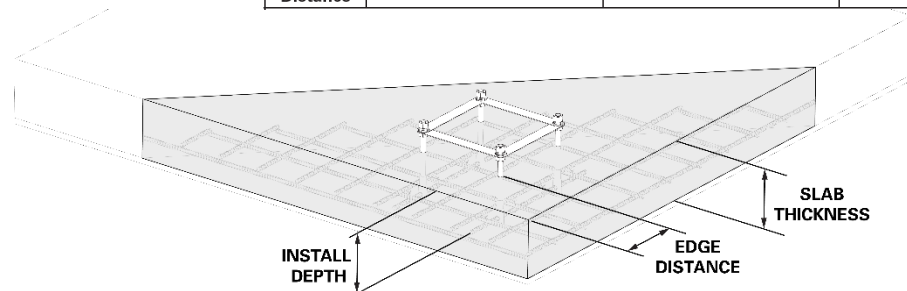

- ▲ Concrete Minimum: 32MPa.
- ▲ Template Material: Steel.
- ▲ Stud Material: 316 Stainless Steel.
- ▲ Install Torque M12: 40Nm.
- ▲ Install Torque M16: 70Nm.



www.safetylink.com



Catalogue



Safety Centre Training

© 2018, SafetyLink Pty Ltd, Australia.

Patents: SafetyLink Pty Ltd has a multitude of patents, patents pending, design applications, trademarks and copyrighted documents both lodged and issued. Should you wish to know the progress of our intellectual property on a specific product please email us on ip@safetylink.com and quote the product code.

Doc ID: MKT-1289 Version: 2.0