

SafetyLink's ConcreteLink Cast In Cages are concrete studs set at the correct spacing for different products. The cages are to be installed prior to the concrete being poured.

- ▲ Tested to AS/NZ5532 when tested with SafetyLink Anchors.
- ▲ Concrete Minimum: 32MPa.
- ▲ Template Material: Steel.
- ▲ Stud Material: Galvanised.
- ▲ Install Torque M16: 70Nm.

CAST-IN CAGE FOR FLOOR MOUNTED DAVIT BASE: PRODUCT CODE: DAVIT_BASE05

Product Parts	Description	Qty
DAVIT_BASE05.01	Cast In Cage Stud M16	4
DAVIT_BASE05.02	Casting Jig for Cast In Cage	2
CON-CAST.02	Reo Bar: 12mm x 595mm	2
WASHER M16_Spring_GAL	Washer: M16 Spring	4
WASHER M16-8.8	Washer: M16 Structural HDG	4
NUT M16-8.8	Nut: M16 Structural HDG	8

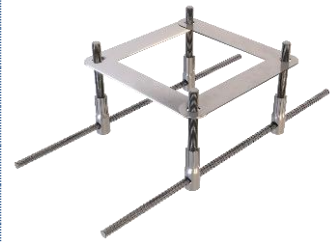

Cast In Cages's shall be installed at the depth, edge distance and slab thickness provided in the installation handbook (see Figure 2 from handbook below).

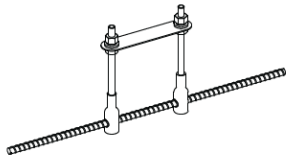
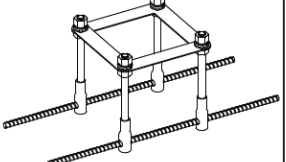
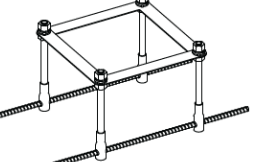
Figure 2			
			
	150mm Tuff Post	300, 600 & 900mm Round Tuff Post	Floor Mounted Davit Base
SS316	CON-CAST-TP150R_SS	CON-CAST-TP300R_SS	N/A
GALV	CON-CAST-TP150R_GAL	CON-CAST-TP300R_GAL	DAVIT_BASE05
Min Install Depth	100mm	110mm	140mm
Min Slab Thickness	150mm	150mm	200mm
Min Edge Distance	150mm	150mm	200mm

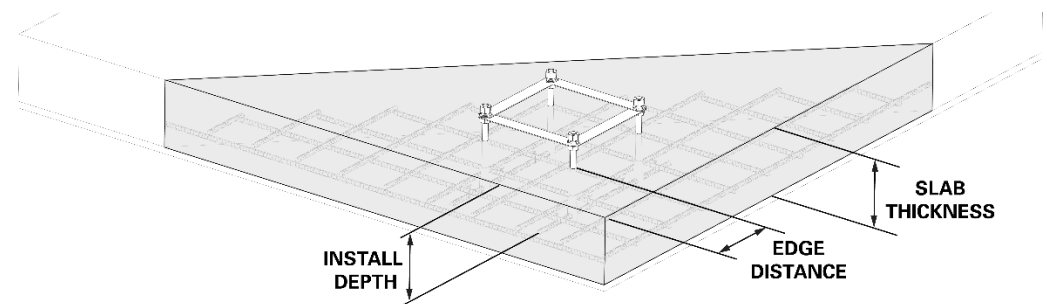

SCAN ME

www.safetylink.com



SCAN ME

Catalogue



SCAN ME

Safety Centre
Training

© 2018, SafetyLink Pty Ltd, Australia.

Patents: SafetyLink Pty Ltd has a multitude of patents, patents pending, design applications, trademarks and copyrighted documents both lodged and issued. Should you wish to know the progress of our intellectual property on a specific product please email us on ip@safetylink.com and quote the product code.

Doc ID: MKT-1290 Version: 2.0