



**SAFETYLINK**  
A DELTA PLUS GROUP COMPANY

# FastFit

## Walkways and Guardrails

### Installation

FIGURE 1



# 1 Contents

<b>1</b>	<b>WARNING</b>	<b>4</b>
<b>2</b>	<b>SPECIFICATION</b>	<b>4</b>
2.1	Description .....	4
2.2	Material Specification.....	4
2.3	Components .....	4
<b>3</b>	<b>INSTALLATION</b>	<b>11</b>
3.1	System Design and Selection .....	11
3.1.1	Location.....	11
3.1.2	Walkway Support Spacing .....	11
3.1.3	Mesh Join Location.....	11
3.1.4	Guardrail Stanchion Spacing .....	12
3.1.5	Guardrailing Over Hang.....	12
3.1.6	Guardrailing Join & Corner Location .....	13
3.1.7	Toeboard Spacing .....	13
3.1.8	Bracing .....	13
3.2	System Requirements .....	14
3.2.1	Guardrail Height.....	14
3.2.2	Walkway Width.....	14
3.2.3	Hand Clearance .....	15
3.2.4	Toeboard.....	15
3.2.5	Rail Spacing.....	16
3.2.6	Guardrailing only .....	17
3.2.7	Platform Guardrailing .....	17
3.2.8	Walkway Cross Slope .....	18
3.2.9	Walkway Direction of Travel Slope .....	18
3.3	Fasteners .....	19
3.3.1	Cup Head Screws .....	19
3.3.2	Tek Screws .....	19
3.3.3	Rivets.....	19
3.3.4	Clamps .....	19
3.3.5	Label.....	19
3.3.6	SafetyLink Concrete Fastener.....	20
3.3.7	Third Party Concrete Fasteners.....	20
<b>4</b>	<b>WALKWAY SUPPORT AND STANCHIONS</b>	<b>21</b>
4.1	Flat Walkway .....	21
4.2	Levelled Walkway (Welded).....	22
4.3	Levelled Walkway (Screw Fix) .....	23
4.4	Single Guardrail Roof Sheet .....	24
4.5	Single Guardrail Concrete Base .....	25
4.6	Single Guardrail Concrete Side .....	26
4.7	Fold Down Guardrail for Roof Sheeting .....	27
4.8	Fold Guardrail for Concrete .....	28
4.9	Single Guardrail with Walkway .....	29
4.10	Single Guardrail with Levelled Walkway .....	30
4.11	Twin Guardrail with Walkway .....	31
4.12	Twin Guardrail with Levelled Walkway.....	32
<b>5</b>	<b>COMPONENT ASSEMBLY</b>	<b>33</b>
5.1	Guardrails.....	33

5.2	Guardrail Joins .....	33
5.3	Brace .....	34
5.4	Mesh Fastening.....	34
5.5	Mesh Joins .....	35
5.6	Mesh Ends.....	35
5.7	Rail Corners.....	36
5.8	Rail Caps.....	36
5.9	Cleats .....	36
5.10	Toeboard.....	37
5.11	Toeboard Join .....	37
5.12	Toeboard Corner .....	37
<b>6</b>	<b>CORNER KITS</b>	<b>38</b>
6.1	Kit 1 .....	38
	6.1.1 <i>Single Guardrail Corner (Flat Roof)</i> .....	38
	6.1.2 <i>Double Guardrail to Single Guardrail Corner (Flat Roof)</i> .....	38
6.2	Kit 2 .....	39
	6.2.1 <i>Single Guardrail Corner (Angled Roof)</i> .....	39
	6.2.2 <i>Double Guardrail Corner (Flat Roof)</i> .....	39
	6.2.3 <i>Double Guardrail T-Intersection (Flat Roof)</i> .....	40
	6.2.4 <i>Double Guardrail to Single Guardrail T-Intersection (Flat Roof)</i> .....	40
6.3	Kit 3 .....	41
	6.3.1 <i>Double Guardrail Corner (Angled Roof)</i> .....	41
6.4	Kit 4.....	42
	6.4.1 <i>Double Guardrail T-Intersection (Angled Roof)</i> .....	42
	6.4.2 <i>Double Guardrail to Single Guardrail T-Intersection (Angled Roof)</i> .....	42
6.5	Kit 5 .....	43
	6.5.1 <i>Double Guardrail to Single Guardrail Corner (Angled Roof)</i> .....	43
	6.5.2 <i>Double Guardrail Corner (Angled Roof)</i> .....	43
<b>7</b>	<b>SKYLIGHT BRIDGING</b>	<b>44</b>
7.1	Walkway Across Skylight with Angle.....	44
7.2	Walkway Across Skylight with Walkway Battens.....	45
7.3	Walkway Along Skylight with Channel Supports .....	46
7.4	Walkway Along Skylight with RHS Supports .....	47
<b>8</b>	<b>SKYLIGHT PROTECTION</b>	<b>48</b>
8.1	Flat .....	48
8.2	Raised .....	49
8.3	Frame.....	50
<b>9</b>	<b>HATCH KITS</b>	<b>51</b>
9.1	Concrete .....	51
9.2	Roof Sheeting .....	53
<b>10</b>	<b>ROOF STAIRS</b>	<b>55</b>
10.1	Installation.....	55
10.2	Joining Walkway.....	57
<b>11</b>	<b>STEPS</b>	<b>58</b>
<b>12</b>	<b>CLAMP FIXINGS</b>	<b>62</b>
12.1	General .....	62
	12.1.1 <i>All Clamp fasteners shall be tightened to 15Nm with a 6mm hex key...</i>	62

12.2	Clamps .....	62
12.2.1	<i>Kliplok 700</i> .....	62
12.2.2	<i>Kliplok 406</i> .....	62
12.2.3	<i>KingZip and KalZip</i> .....	62
12.2.4	<i>Standing Seam</i> .....	63
12.3	Installations .....	63
12.3.1	<i>Walkway Across Seams</i> .....	63
12.3.2	<i>Walkway Along Seams</i> .....	63
12.3.3	<i>Walkway Long Span</i> .....	64
12.3.4	<i>Single Guardrail</i> .....	65
12.3.5	<i>Double Guardrail</i> .....	65
<b>13</b>	<b>TOOLS</b>	<b>66</b>
13.1	Middle Rail Spacer.....	66
<b>14</b>	<b>INSPECTION</b>	<b>67</b>
14.1	Inspection Period .....	67

# 1 Warning

- ⚠ Improper Use, Installation or Maintenance may result in serious injury or death.**
- ⚠ The structure or anchorage to which SafetyLink products are to be installed shall be assessed by a professional engineer to ensure it has adequate strength to support the product.**
- ⚠ SafetyLink products shall be installed, used and maintained in accordance with the applicable SafetyLink installation and use manual.**
- ⚠ SafetyLink’s product shall be used in accordance with the current working at height standards, codes of practice, regulation or legislation in the region of use.**
- ⚠ During installation, use and maintenance, personnel shall not be exposed to a fall hazard.**
- ⚠ Installation is to be carried out by, or under the supervision of, a competent person.**
- ⚠ The installer shall complete the applicable SafetyLink online training modules before installing this product.**
- ⚠ Connection systems used with SafetyLink Anchor, Lifelines and Rigid Rail Systems shall contain a personal energy absorber.**
- ⚠ Do not carry out any modifications to this product without written permission from SafetyLink.**

# 2 Specification

## 2.1 Description



SafetyLink Walkways are a modular access system for permanent installation in a wide variety of scenarios. SafetyLink Walkways are design to and when installed in accordance with this manual are compliant with AS 1657:2018.



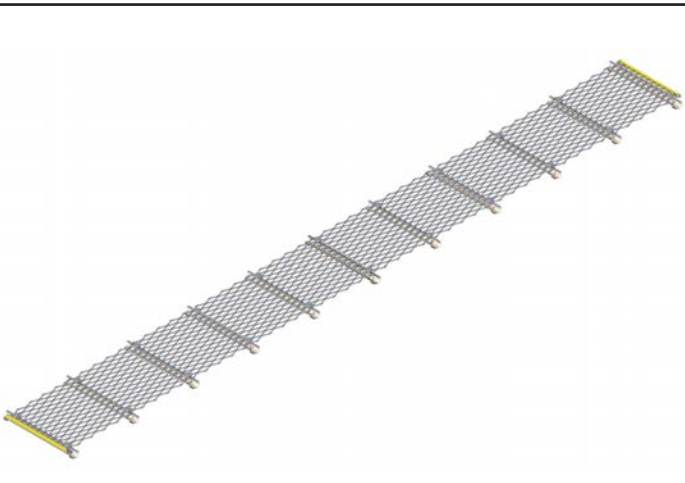
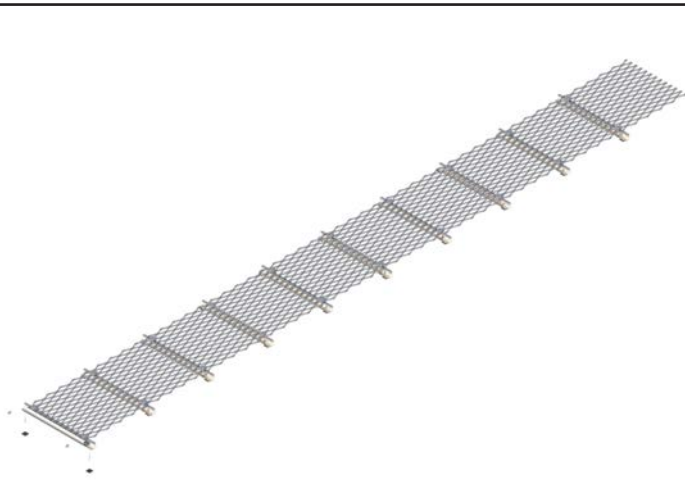

## 2.2 Material Specification

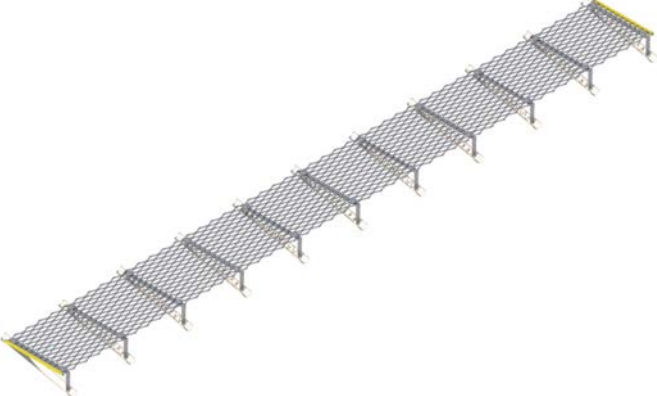
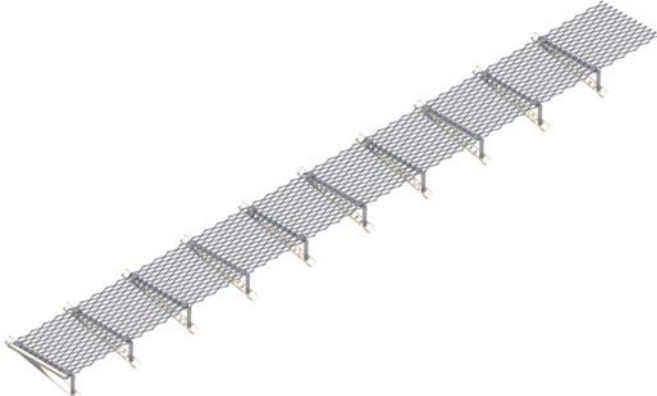

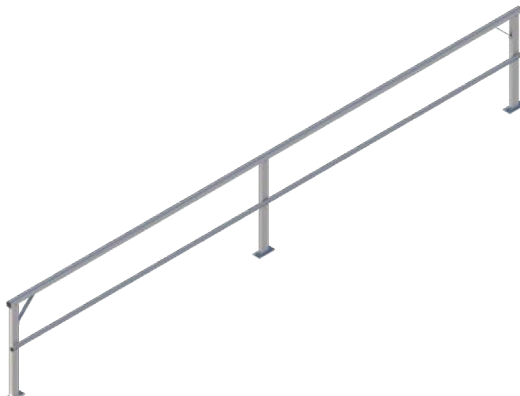
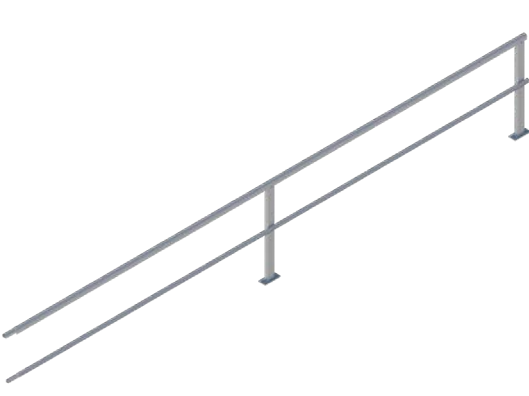
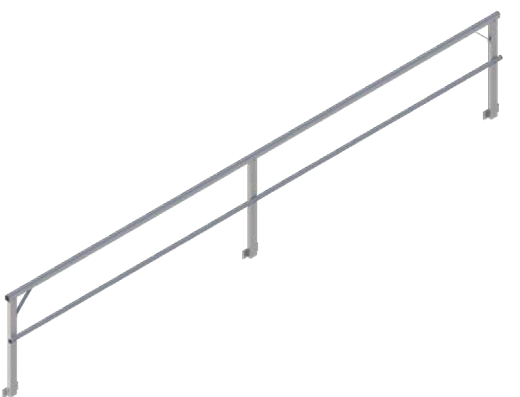
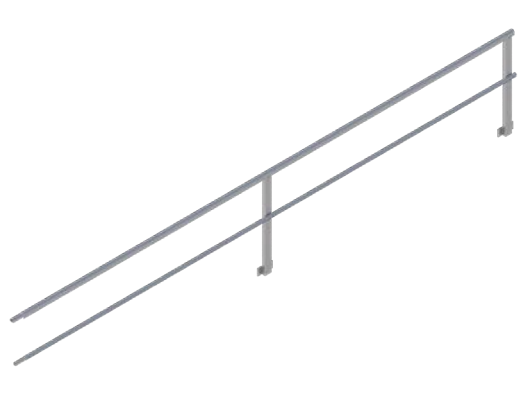

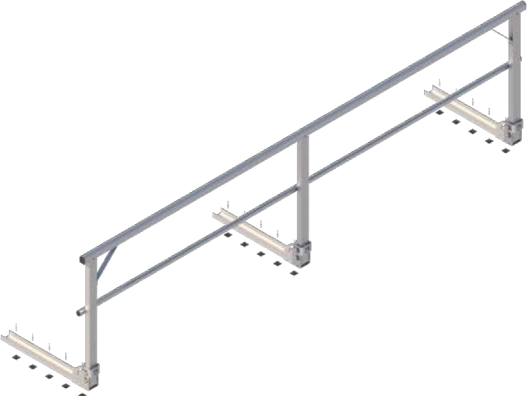
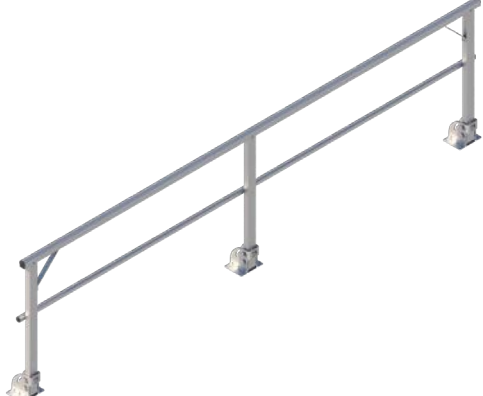

<b>FIGURE 2</b>	
<b>COMPONENT</b>	<b>DESCRIPTION</b>
Mesh, Guardrails and supports	Aluminium 6000 series
Caps	Polyethylene
Fasteners	See Section 3.3

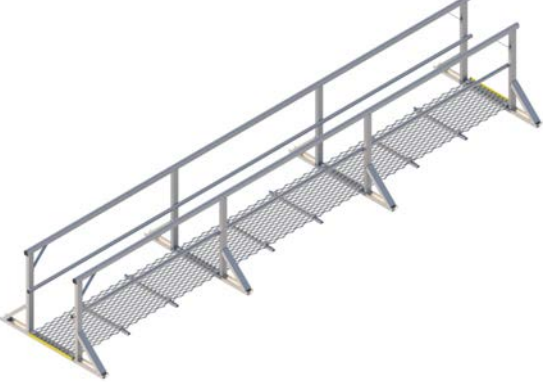
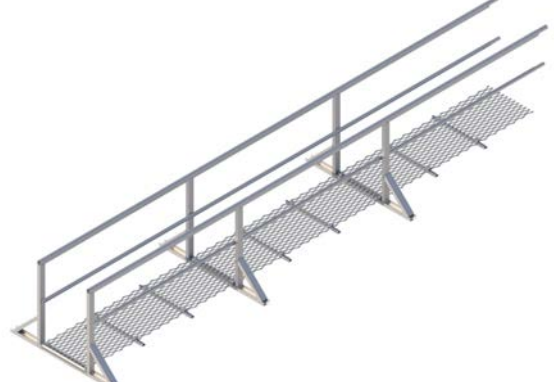
## 2.3 Components

<b>FIGURE 3</b>	
	
<b>GUARDK101</b>	<b>GUARDK102</b>
See Section 4.1 on page 22	See Section 4.1 on page 22

	
<p style="text-align: center;"><b>GUARDK111</b></p>	<p style="text-align: center;"><b>GUARDK112</b></p>
<p style="text-align: center;">See Section 4.2 on page 23</p>	<p style="text-align: center;">See Section 4.2 on page 23</p>
	
<p style="text-align: center;"><b>GUARDK141</b></p>	<p style="text-align: center;"><b>GUARDK142</b></p>
<p style="text-align: center;">See Section 4.4 on page 25</p>	<p style="text-align: center;">See Section 4.4 on page 25</p>
	
<p style="text-align: center;"><b>GUARDK121</b></p>	<p style="text-align: center;"><b>GUARDK122</b></p>
<p style="text-align: center;">See Section 4.5 on page 26</p>	<p style="text-align: center;">See Section 4.5 on page 26</p>
	
<p style="text-align: center;"><b>GUARDK131</b></p>	<p style="text-align: center;"><b>GUARDK132</b></p>
<p style="text-align: center;">See Section 4.6 on page 27</p>	<p style="text-align: center;">See Section 4.6 on page 27</p>

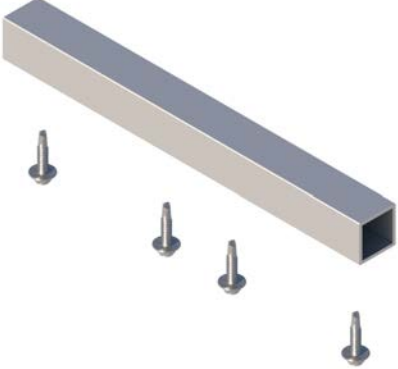
	
<p>GUARDK192, GUARDK193, GUARDK194 See Section 4.7 on page 28</p>	<p>GUARDK202, GUARDK203, GUARDK204 See Section 4.8 on page 29</p>
	
<p>GUARDK151 See Section 4.9 on page 30</p>	<p>GUARDK152 See Section 4.9 on page 30</p>
	
<p>GUARDK161 See Section 4.10 on page 31</p>	<p>GUARDK162 See Section 4.10 on page 31</p>
	
<p>GUARDK171 See Section 4.11 on page 32</p>	<p>GUARDK171 See Section 4.11 on page 32</p>

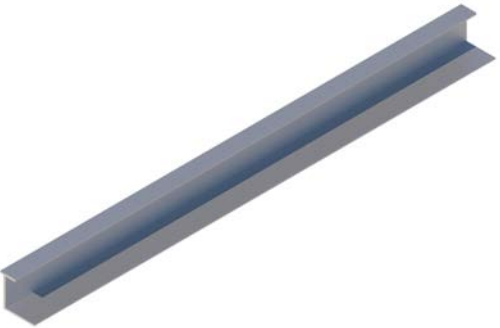
	
<p style="text-align: center;"><b>GUARDK181</b></p>	<p style="text-align: center;"><b>GUARDK182</b></p>
<p style="text-align: center;">See Section 4.12 on page 33</p>	<p style="text-align: center;">See Section 4.12 on page 33</p>
	
<p style="text-align: center;"><b>GUARD_HR</b></p>	<p style="text-align: center;"><b>GUARD_KR</b></p>
<p style="text-align: center;">See Section 5.1 on page 34</p>	<p style="text-align: center;">See Section 5.1 on page 34</p>
	
<p style="text-align: center;"><b>GUARD001.HR.SPL</b></p>	<p style="text-align: center;"><b>GUARD001.KR.SPL</b></p>
<p style="text-align: center;">See Section 5.2 on page 34</p>	<p style="text-align: center;">See Section 5.2 on page 34</p>
	
<p style="text-align: center;"><b>GUARD_HR.BRACE</b></p>	<p style="text-align: center;"><b>GUARD_WALK.CHL.700</b></p>
<p style="text-align: center;">See Section 5.3 on page 35</p>	<p style="text-align: center;">See Section 5.4 on page 35</p>

	
<p>GUARD_JOIN.595</p>	<p>GUARD_END.Y.595</p>
<p>See Section 5.5 on page 36</p>	<p>See Section 5.6 on page 36</p>
	
<p>GUARD_END.595</p>	<p>GUARD_HR.ELBW</p>
<p>See Section 5.6 on page 36</p>	<p>See Section 5.7 on page 37</p>
	
<p>GUARD_KR.ELBW</p>	<p>GUARD_HR.CAP</p>
<p>See Section 5.7 on page 37</p>	<p>See Section 5.8 on page 37</p>
	
<p>GUARD_KR.CAP</p>	<p>GUARD_CLEAT.595</p>
<p>See Section 5.8 on page 37</p>	<p>See Section 5.9 on page 37</p>

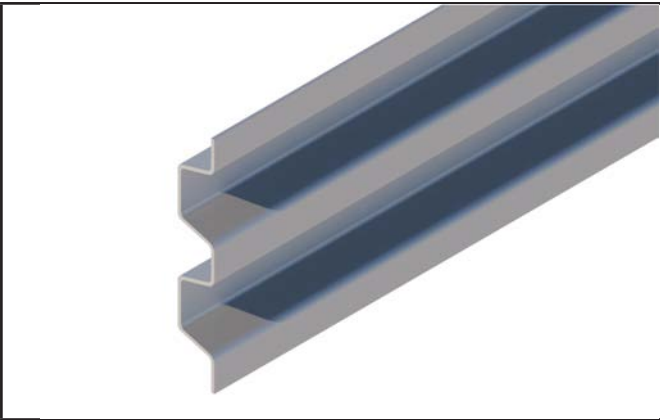

AL\_RUB\_RAIL

See Section 5.10 on page 38

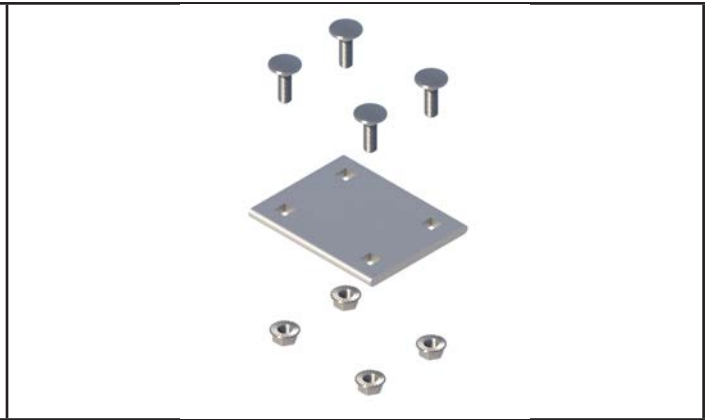

GUARD\_TOE.JOIN

See Section 5.11 on page 38

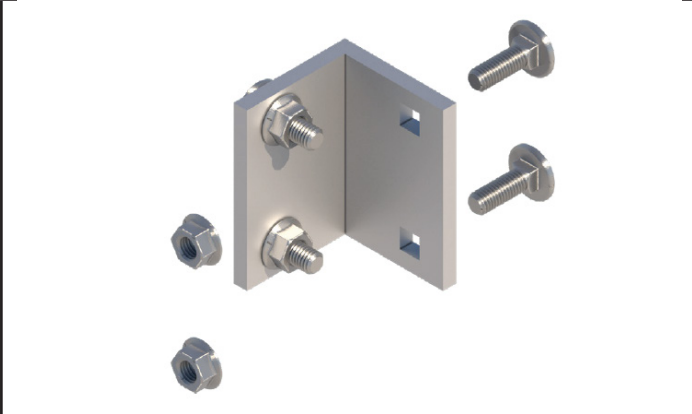

GUARD\_TOE.CNR

See Section 5.12 on page 38

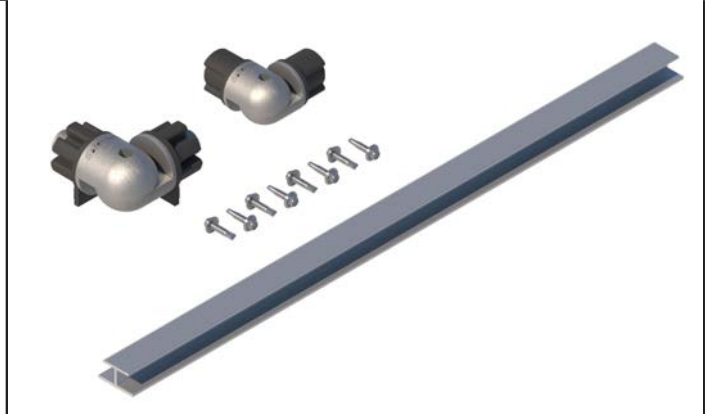

GUARDK\_CNR.01

See Section 6.1 on page 39

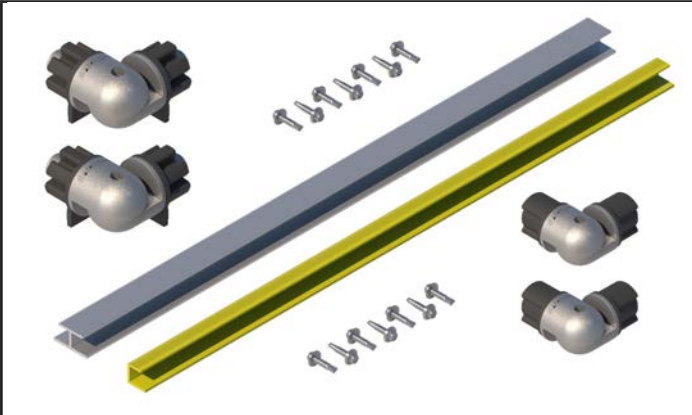

GUARDK\_CNR.02

See Section 6.2 on page 40

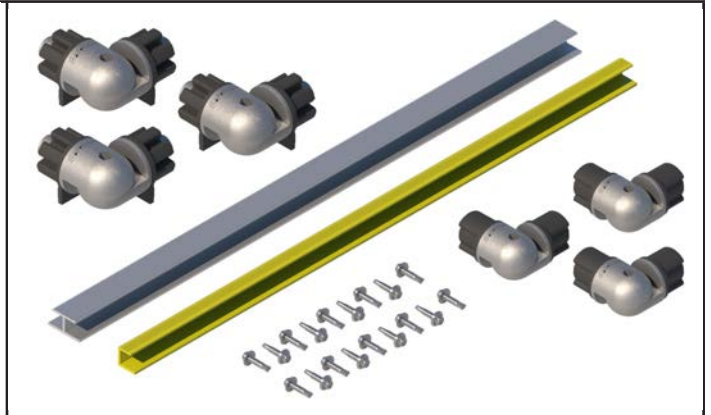

GUARDK\_CNR.03

See Section 6.3 on page 42

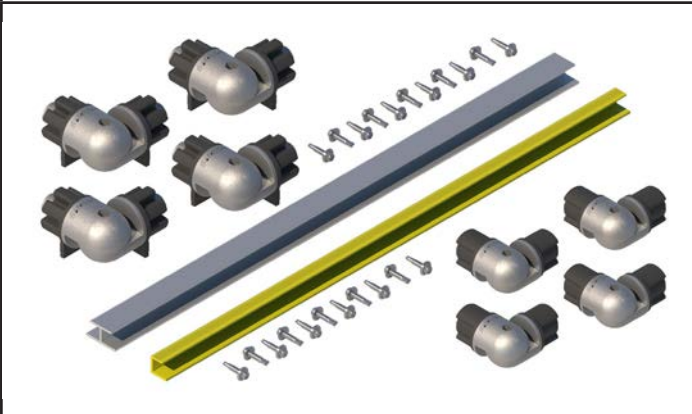





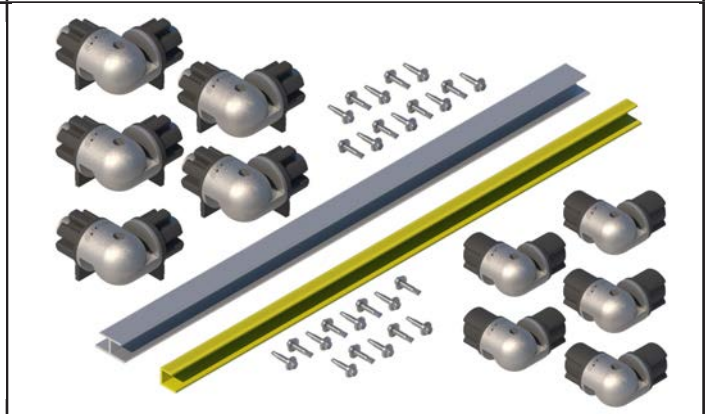

GUARDK\_CNR.04

See Section 6.4 on page 43

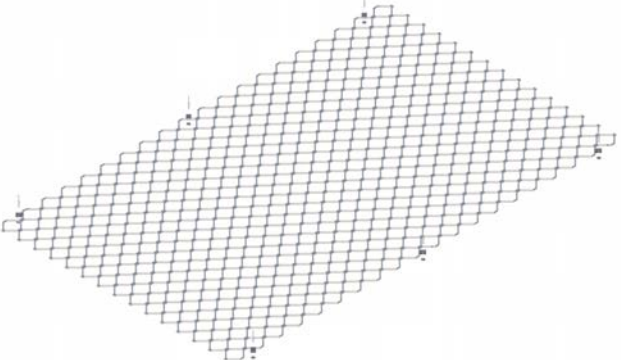
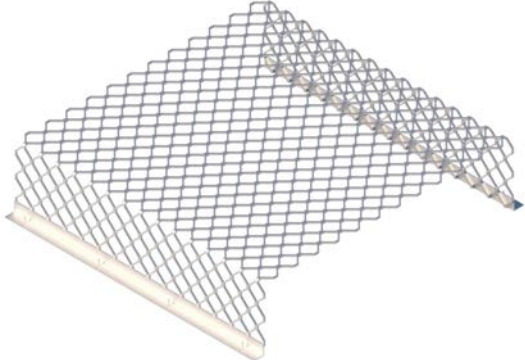

GUARDK\_CNR.05

See Section 6.5 on page 44

	
<p><b>GUARD_SKYL.XXX.XXXX</b> See Section 8.1 on page 49</p>	<p><b>GUARD_SKYB.XXX.XXXX</b> See Section 8.2 on page 50</p>
	
<p><b>GUARD_SKYF.1250.1250</b> See Section 8.3 on page 51</p>	<p><b>GUARD001.HATCH_CON</b> See Section 9.1 on page 52</p>
	
<p><b>GUARD001.HATCH_SM</b> See Section 9.2 on page 54</p>	<p><b>GUARD_SKY.FIXINGS</b> See Section 8.1 on page 49</p>
	
<p><b>STAIR001</b> See Section 10 on page 56</p>	

### 3 Installation

#### 3.1 System Design and Selection

##### 3.1.1 Location

Determining the best location for your access system can be difficult. SafetyLink recommends a risk assessment be conducted to accurately assess the key hazards of your particular work area. Hazards include but are not limited to; ingress and egress from the access system, machinery and vehicles use in the area, electrical conductivity and chemical agents.

##### 3.1.2 Walkway Support Spacing

- I The walkway mesh supports shall be spaced no greater than 700mm apart.

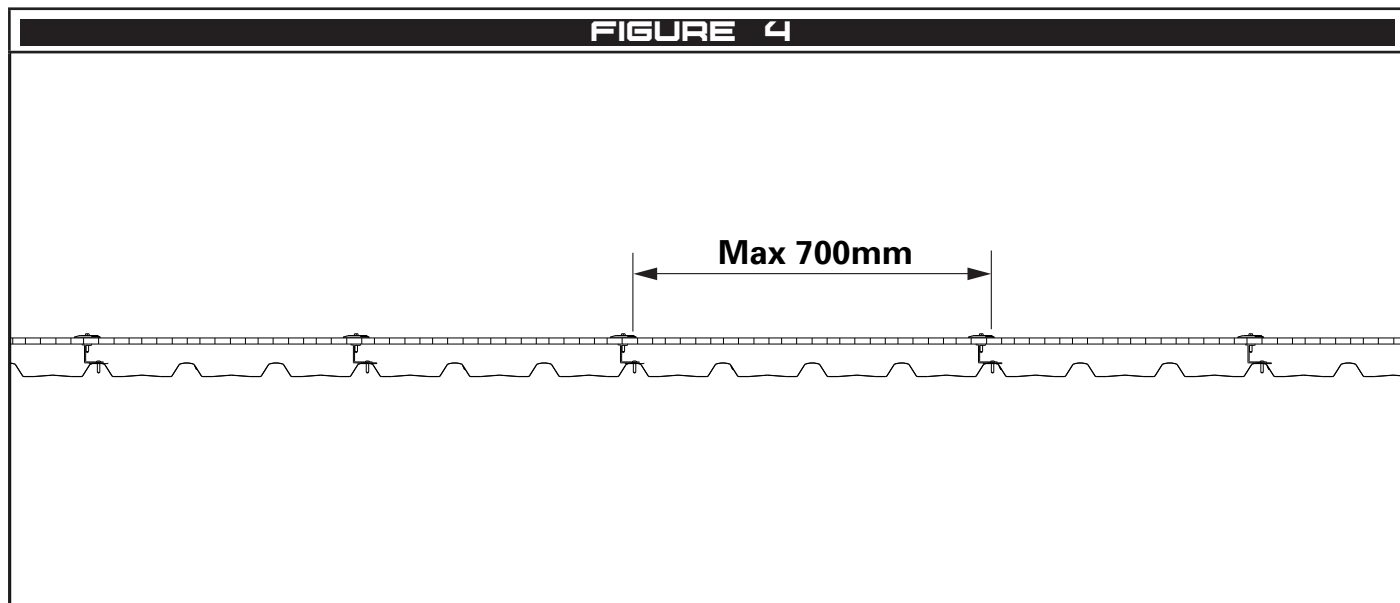

##### 3.1.3 Mesh Join Location

- I Joins in the walk way shall not be more than 200mm from a support.

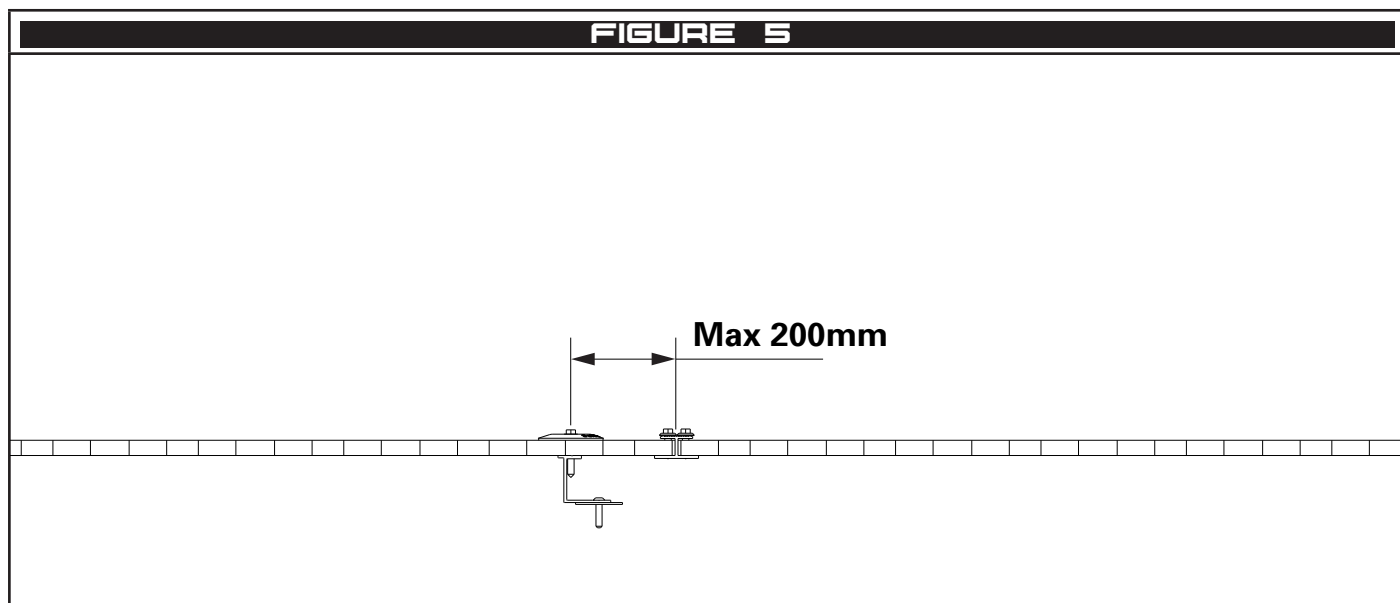

### 3.1.4 Guardrail Stanchion Spacing

- I Stanchion shall be spaced at a maximum of 2300mm. See Figure 6.
- II For heavy duty stanchions GUARD001.WW.POST.02 and GUARD001.WW.POST.04 the maximum spacing shall be 3000mm. See Figure 7. These stanchions are found in kits, GUARDK121, GUARDK122, GUARDK131 and GUARDK132.

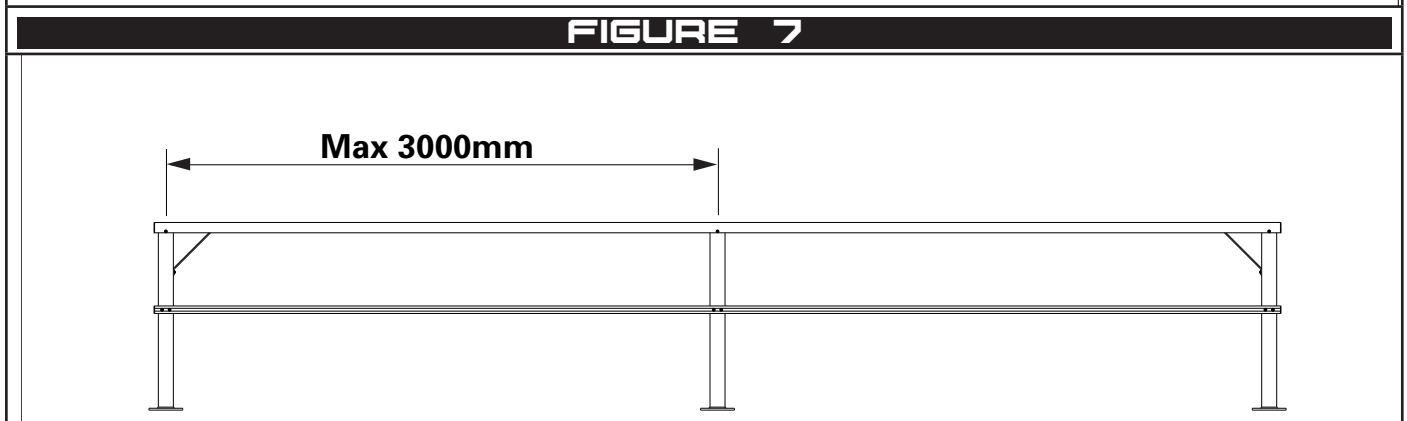
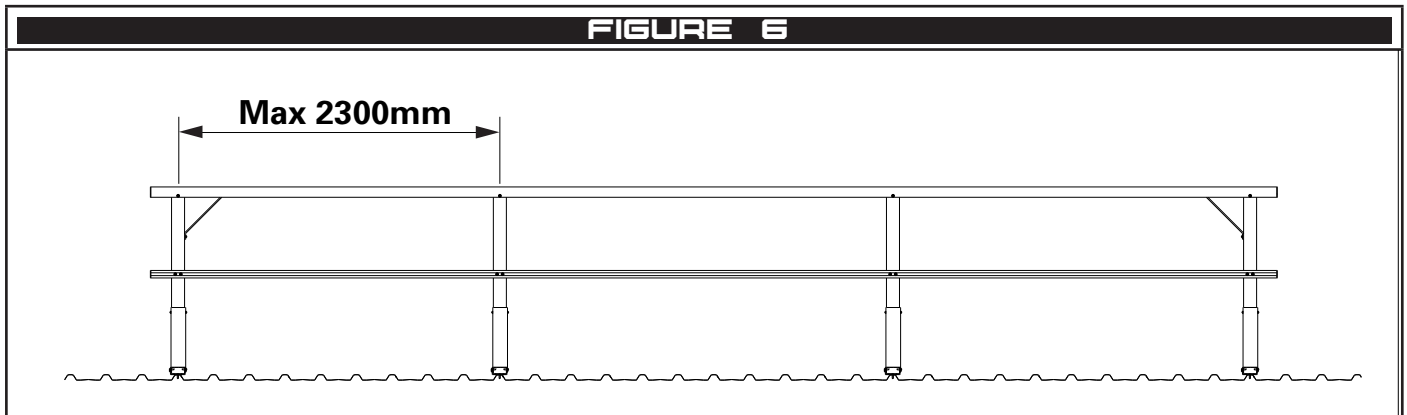

### 3.1.5 Guardrailing Over Hang

- I At the end of the guardrail section, the rails and toeboard shall not over hang a post more than 300mm.

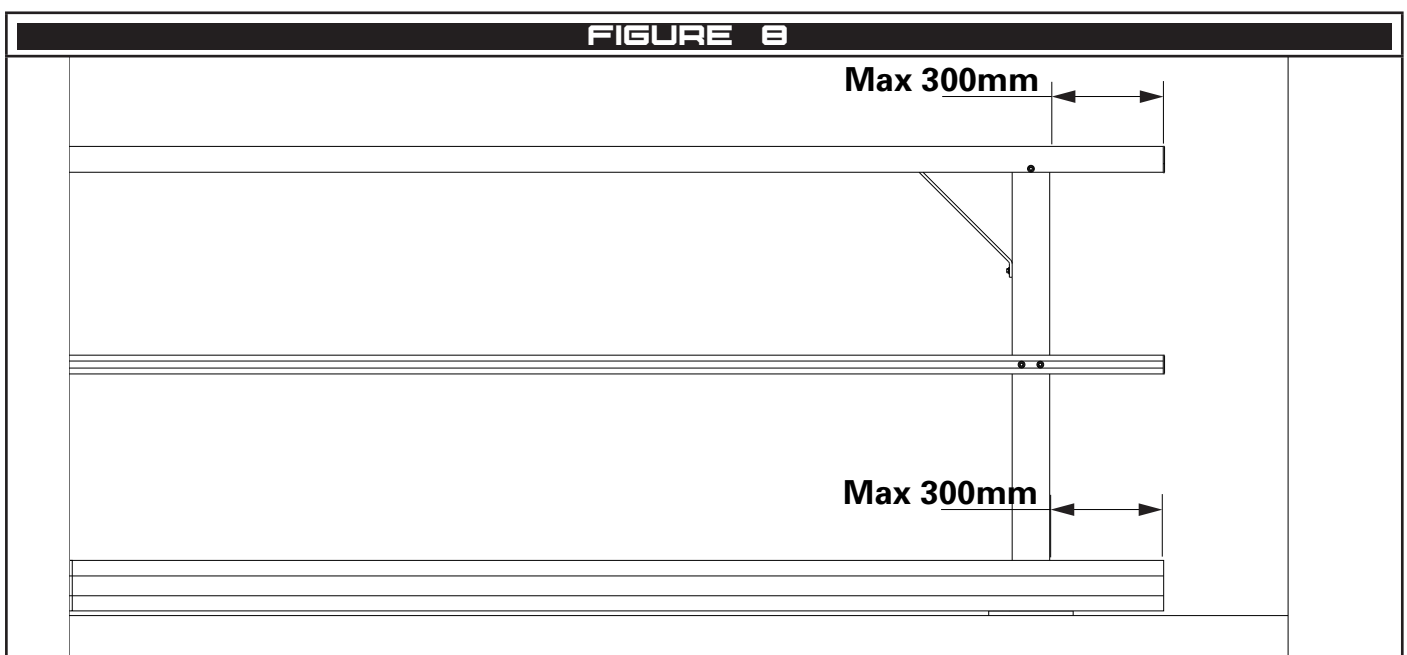



### 3.2 System Requirements

The following requirements are mandatory for Compliance with the AS1657:2018.

#### 3.2.1 Guardrail Height

- I The guardrail height shall be not less than 900mm above the surface of the walkway.
- II If the guardrail is greater than 1065mm above the surface of the walkway, another intermediate rail shall be installed.

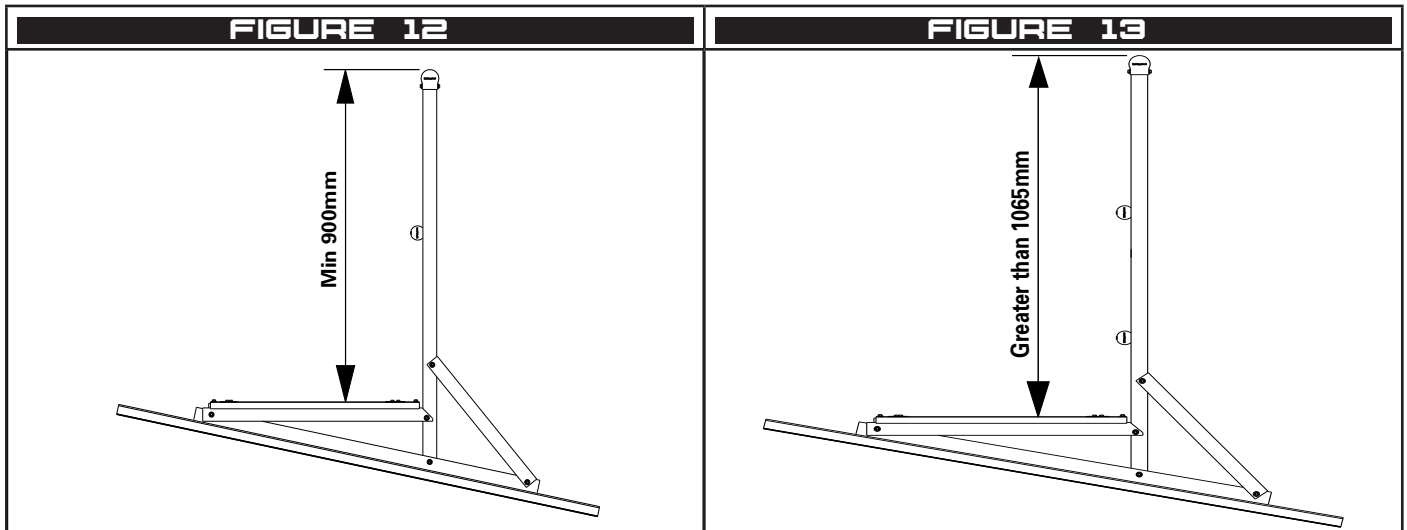

#### 3.2.2 Walkway Width

- I The walkway shall be at least 600mm wide
- II The clearance between guardrail components shall be not less than 550mm

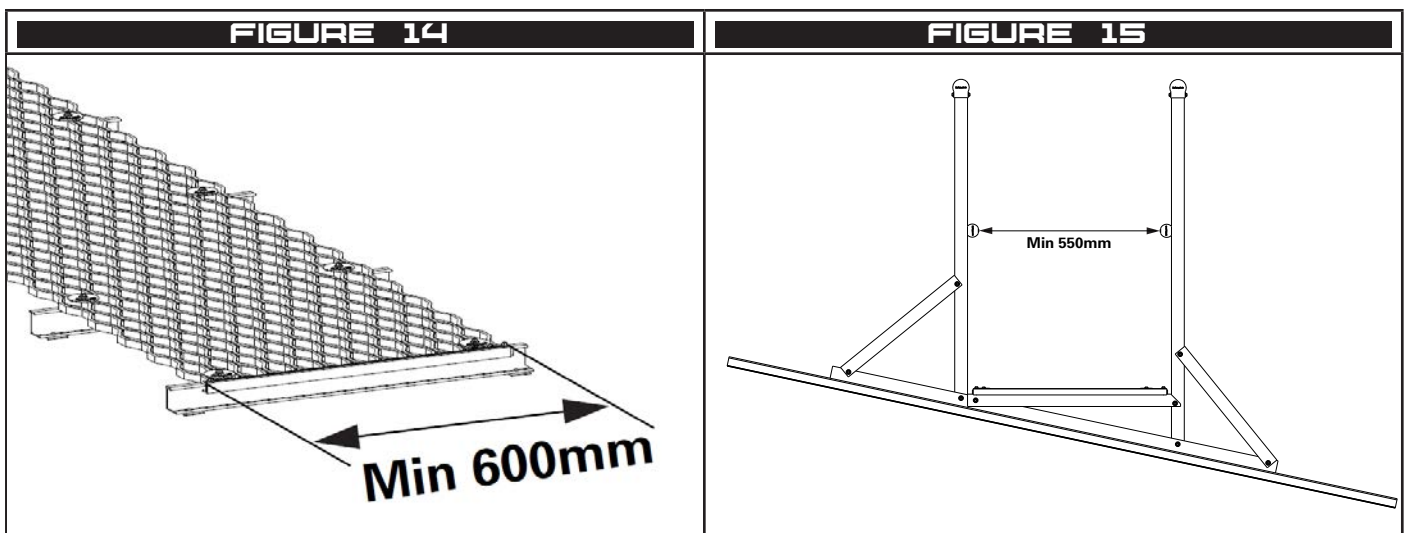

### 3.2.3 Hand Clearance

- I There shall be a minimum of 50mm clearance around the handrail.

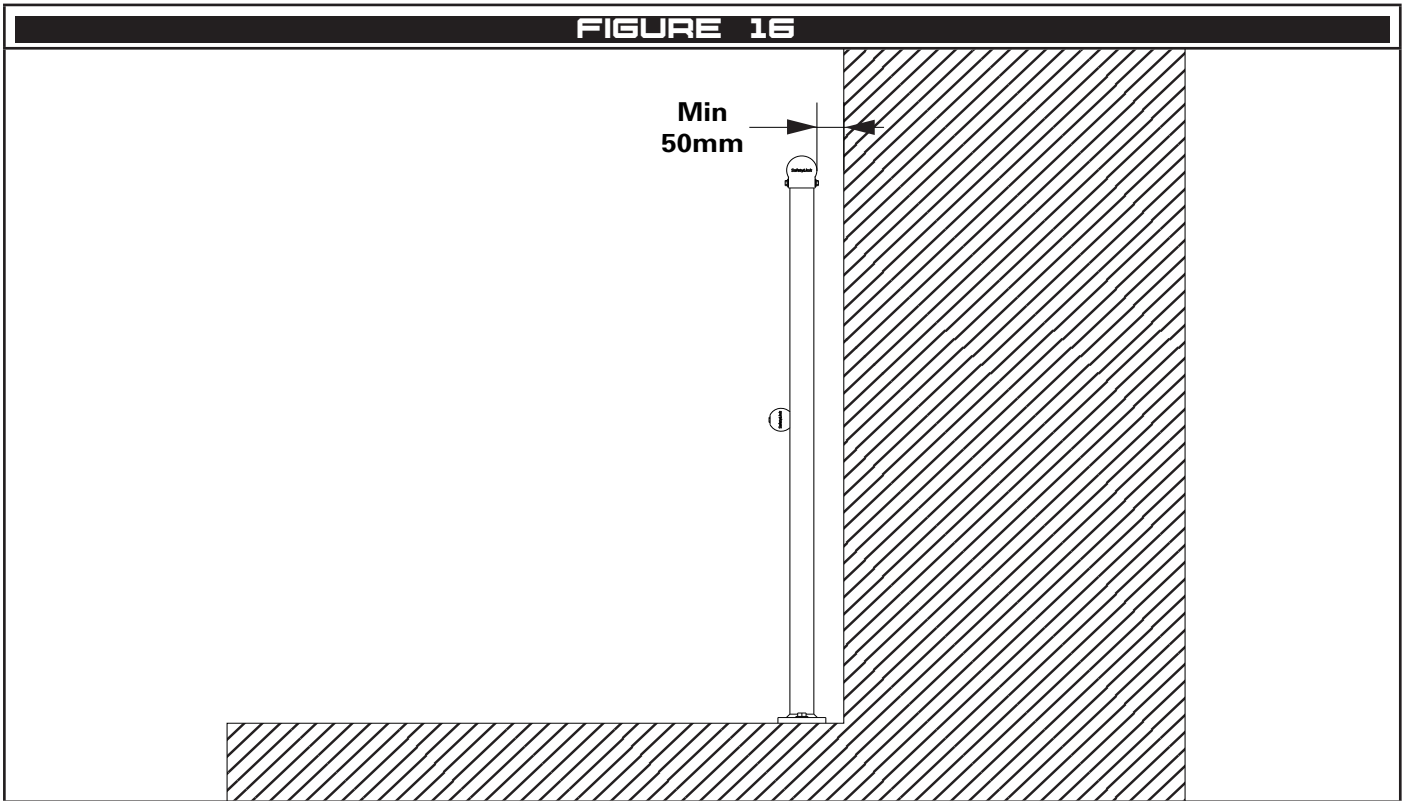

### 3.2.4 Toeboard

- I Toeboards shall be installed on the edge of walkways where there is the risk that an object could fall to where people have access to the area below.

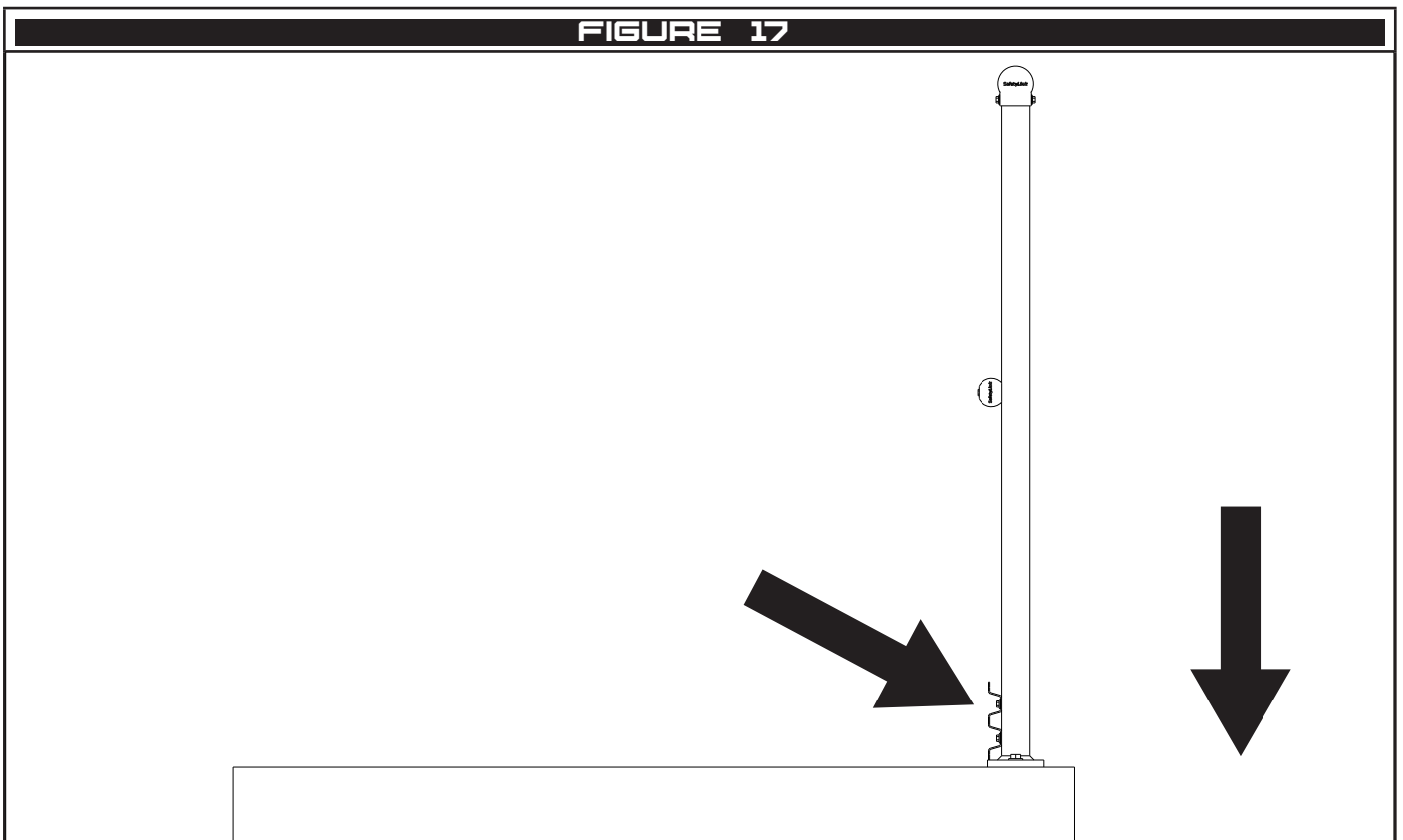

### 3.2.5 Rail Spacing

- I The distance between the top and middle rail cannot be less than 450mm.
- II The distance between the middle rail and the walkway surface cannot exceed 560mm.
- III Where a toeboard is installed the distance from the middle rail to the toeboard shall not exceed 450mm.

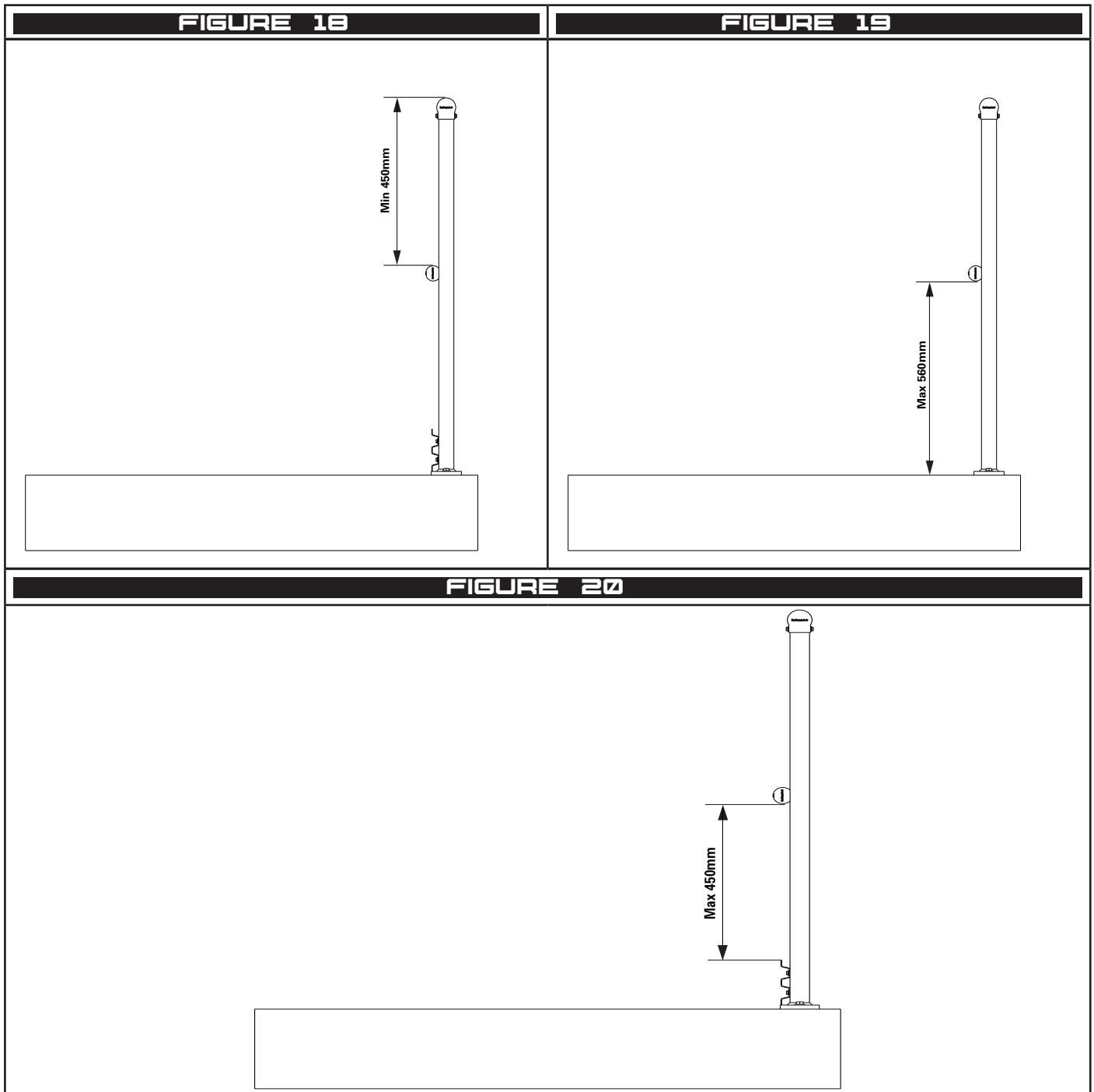

### 3.2.6 Guardrailing only

- I Where guardrailing is installed on a sloped surface greater than  $12^\circ$  without a leveled walkway, a third rail is recommended to be installed (maximum height 250mm).

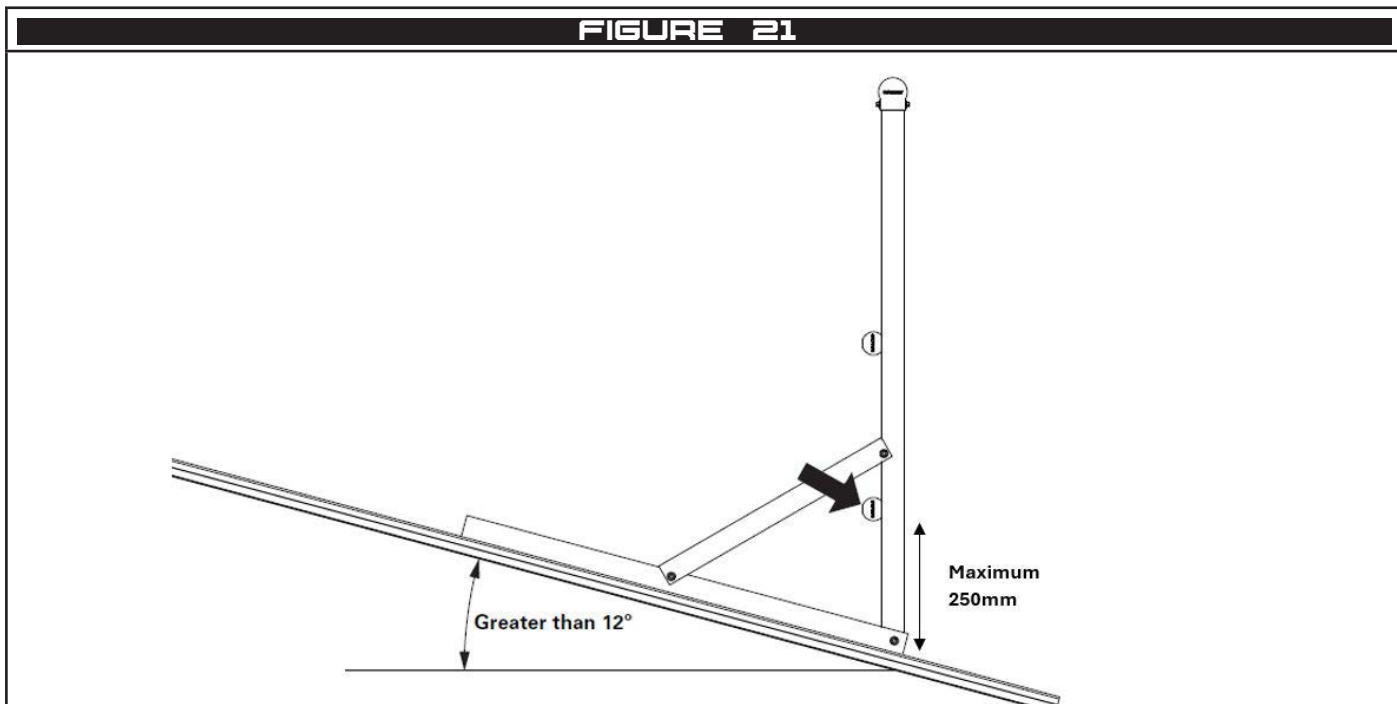

### 3.2.7 Platform Guardrailing

- I Guardrailing is not required around a platform if the height to the lower walking surface is less than 300mm and the distance to an existing guardrail is more than 1000mm.
- II Where the distance to an existing guardrail is less than 1000mm, the guardrail height must be increased by 300mm.

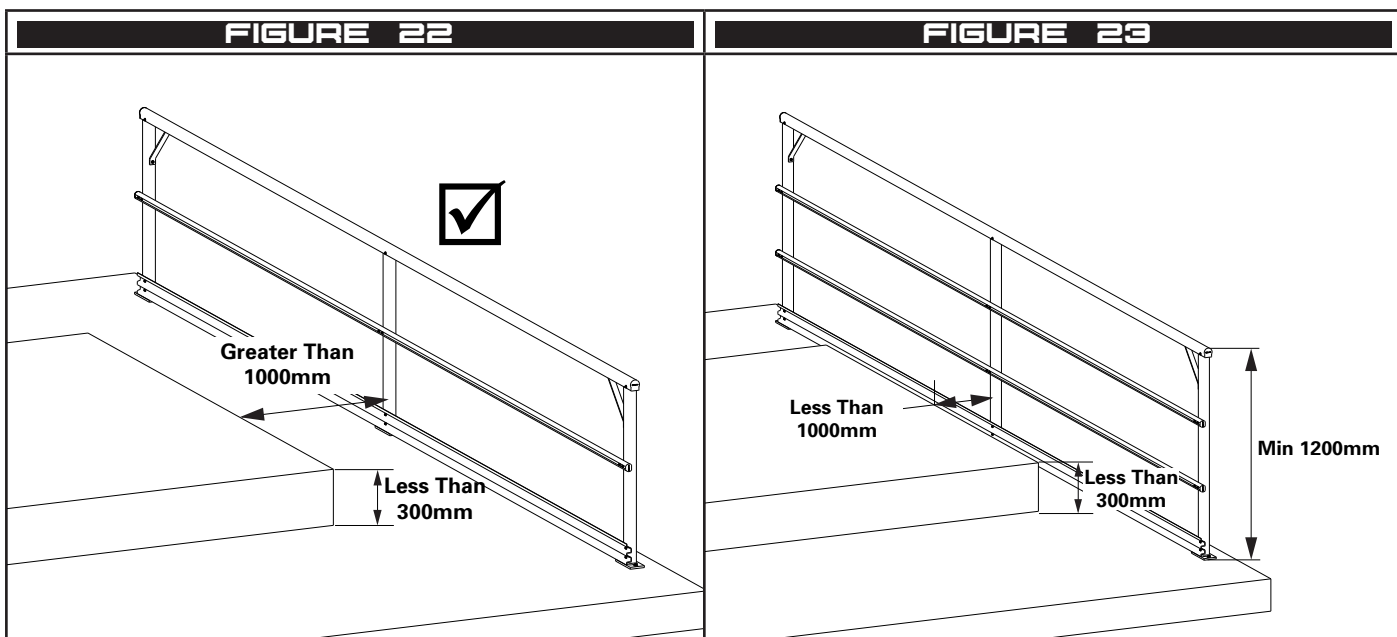

### 3.2.8 Walkway Cross Slope

- I Across the walk way shall not exceed 7°.
- ☑ The preferred range is not greater than 3°.
- II Where the cross slope of a walkway exceeds 12° a guardrail is required on the downside of the walkway.

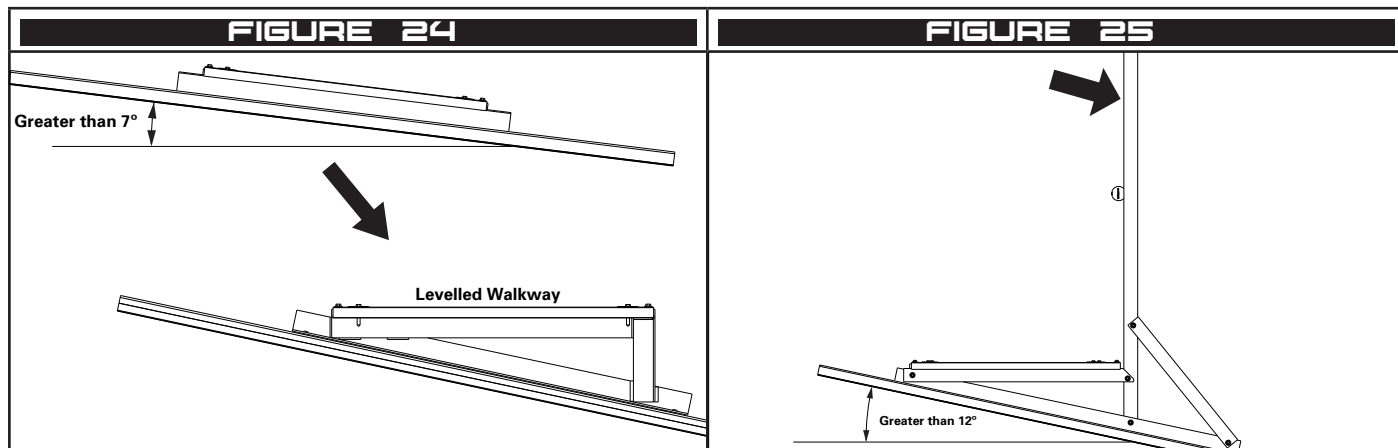

### 3.2.9 Walkway Direction of Travel Slope

- I In the direction of travel shall not exceed 20°. See Figure 26. For angles over 20° See Section 10.
- II Where the angle of the walkway exceeds 10° in the direction of travel cleat shall be installed. See Figure 27 and Figure 28.
- III For roof angles exceeding 12°, a guardrail should be installed on both sides of the walkway. See Figure 29.

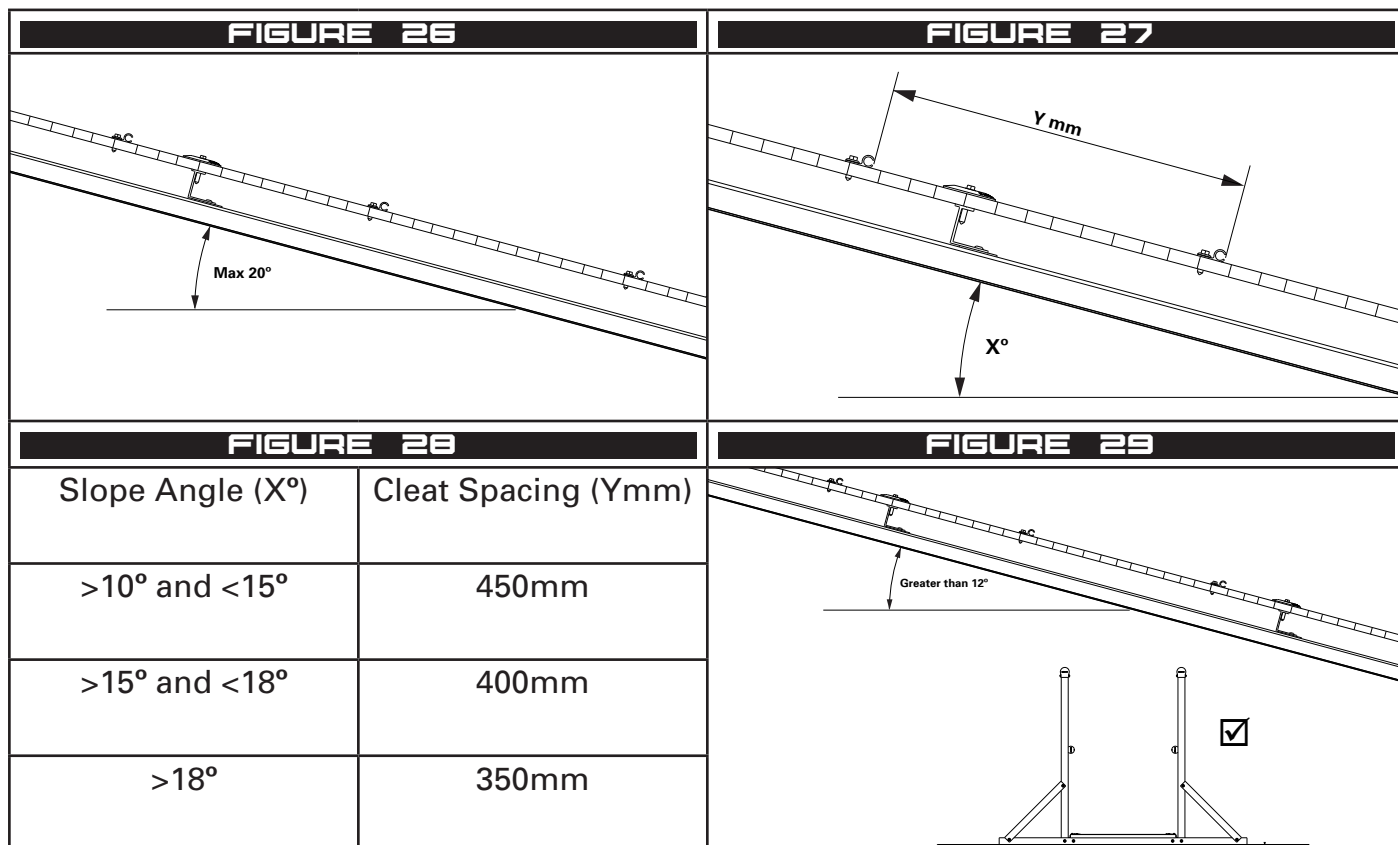

### 3.3 Fasteners

#### 3.3.1 Cup Head Screws

All Walkway Fasteners are M8 cup head cap screws, stainless steel 316. All fasteners shall be tightened to 20Nm with a 13mm Socket, C or ring spanner.

#### 3.3.2 Tek Screws

All supplied Tek Screws are 12 gauge hot dip galvanised hi tensile steel. All are to be installed with a 3/8" drive socket.

#### 3.3.3 Rivets

All supplied rivets are Ø5mm aluminium trifold rivets. These can be installed with a manual riveting tool or a powered riveting tool.

#### 3.3.4 Clamps

For penetrationless fixings to a variety of roof type see Section 12.

#### 3.3.5 Label

All systems shall be marked with the label shown in Figure 30. The label shall be filled out by the installer and fixed with 2 x trifold rivets.



### 3.3.6 SafetyLink Concrete Fastener

SafetyLink's M10 Concrete Stud CON-M10X130 is to be installed with chemical adhesive CON-CHEM-FISV.300.

1. Mark the location for the hole.

 ***The location shall be no less than 150mm from any edge.***

 ***The concrete shall measure not less than 150mm thick.***

 ***The stud shall only be installed in crack free concrete 32MPa or greater.***

 ***Consult a structural engineer if there is any doubt of the suitability of the structure.***

2. Set the drill depth to 95mm and drill a 12mm diameter hole.

3. Clean the hole, ensuring it is free of moisture and dust.

4. Inject the adhesive in to the hole as per the manufacturer's instruction.

5. Insert the stud to full depth, 35mm of the stud should remain above the surface. Wipe away any adhesive expelled from the hole.

 ***Ensure enough adhesive was used, the adhesive should finish flush with the concrete.***

6. Once the adhesive is cured, install the spring washer and tighten the Donut to 20Nm.

### 3.3.7 Third Party Concrete Fasteners

Other suitable concrete fasteners are listed below. Fasteners of equivalent strength to that listed below may be used. All fasteners shall be installed in accordance with the manufacturer's requirements.

I Fischer FAZ II minimum M10 x 55 (Expansion Bolt)

II Fischer FH II minimum M10 x 70 (Expansion Bolt)

III Fischer ULTRACUT US FBS II minimum M10x85 (Concrete Screw)

## 4 Walkway Support and Stanchions

### 4.1 Flat Walkway

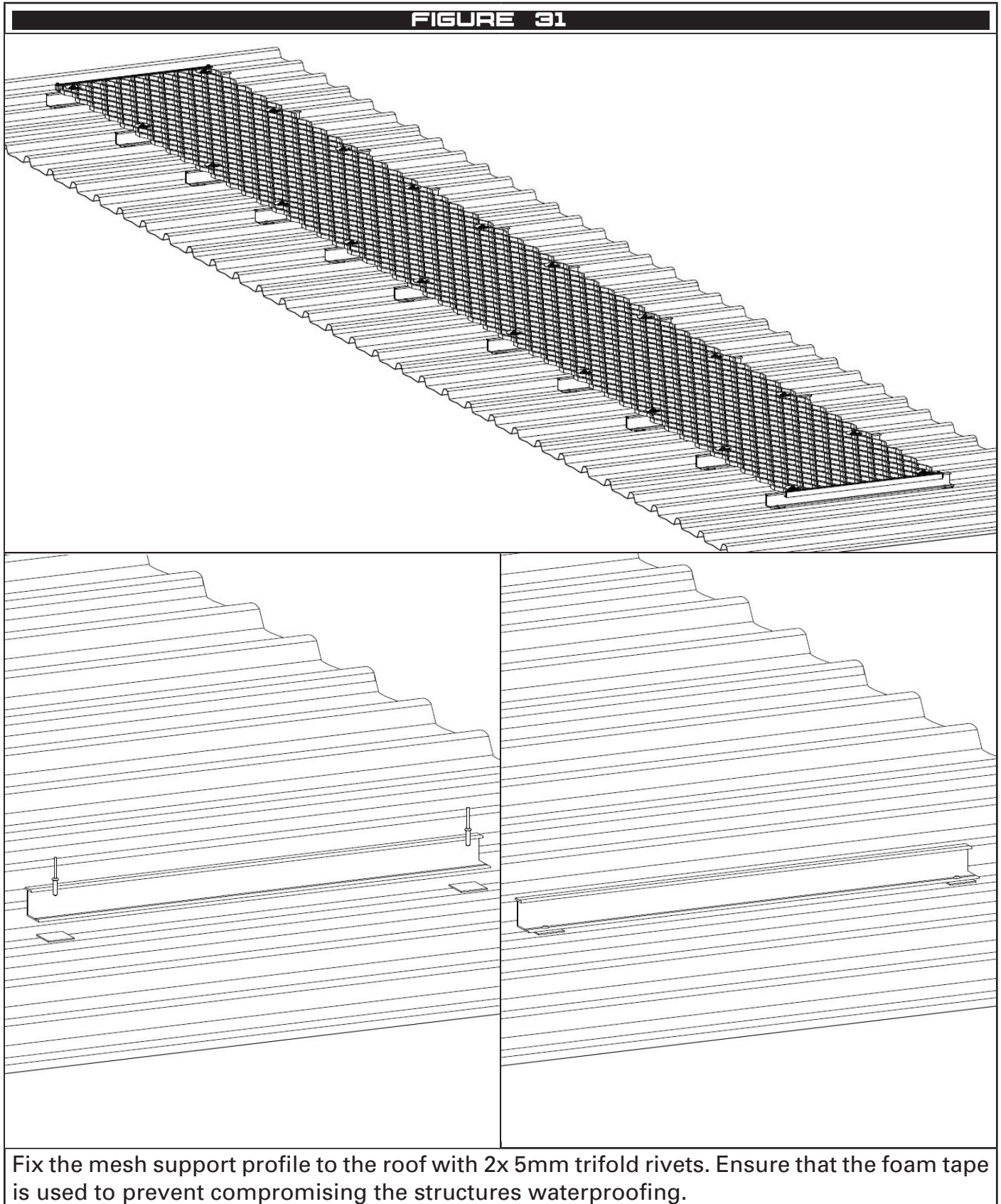

## 4.2 Levelled Walkway (Welded)

FIGURE 32

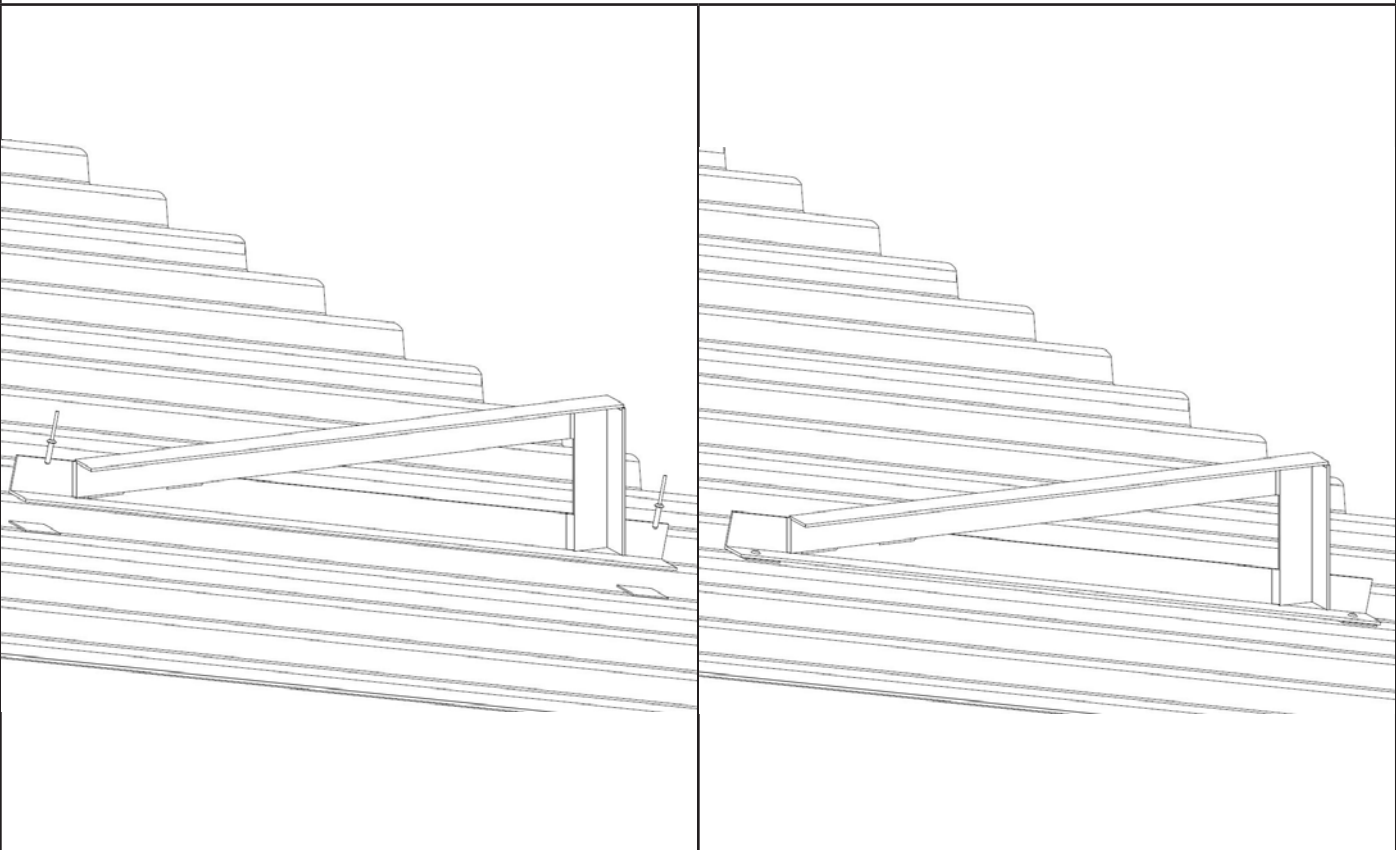
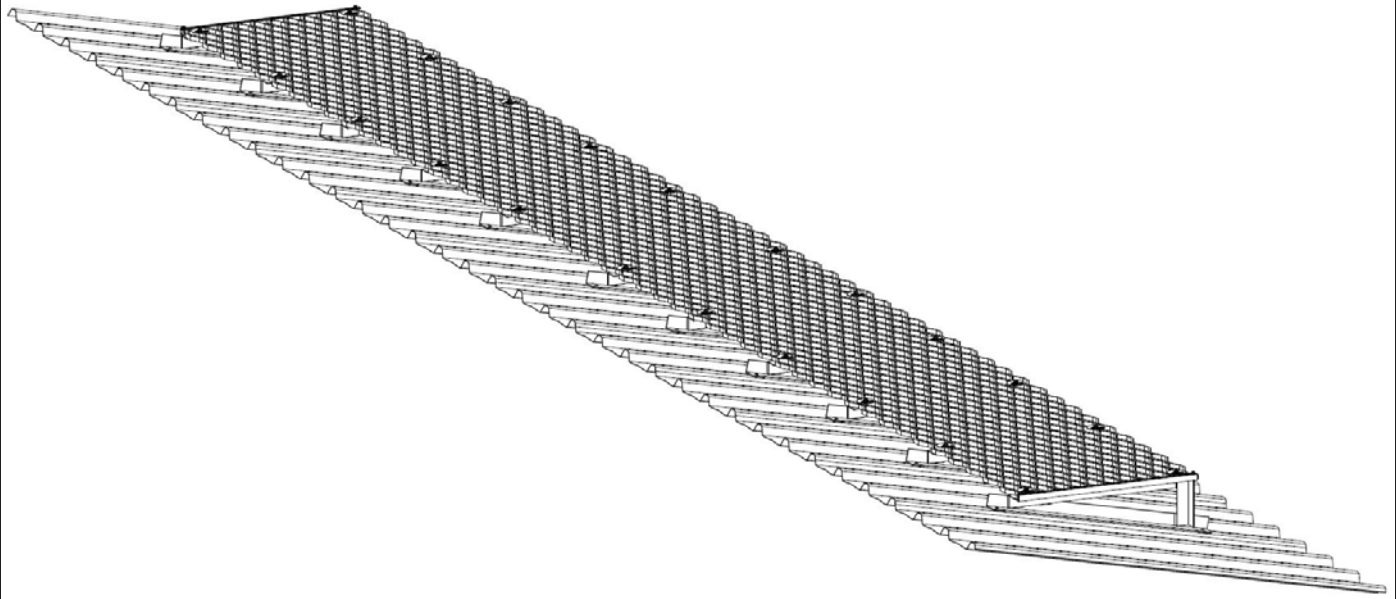

Fix the mesh levelled supports to the roof with 2x 5mm trifold rivets. Ensure that the foam tape is used to prevent compromising the structures waterproofing.

### 4.3 Levelled Walkway (Screw Fix)

FIGURE 33

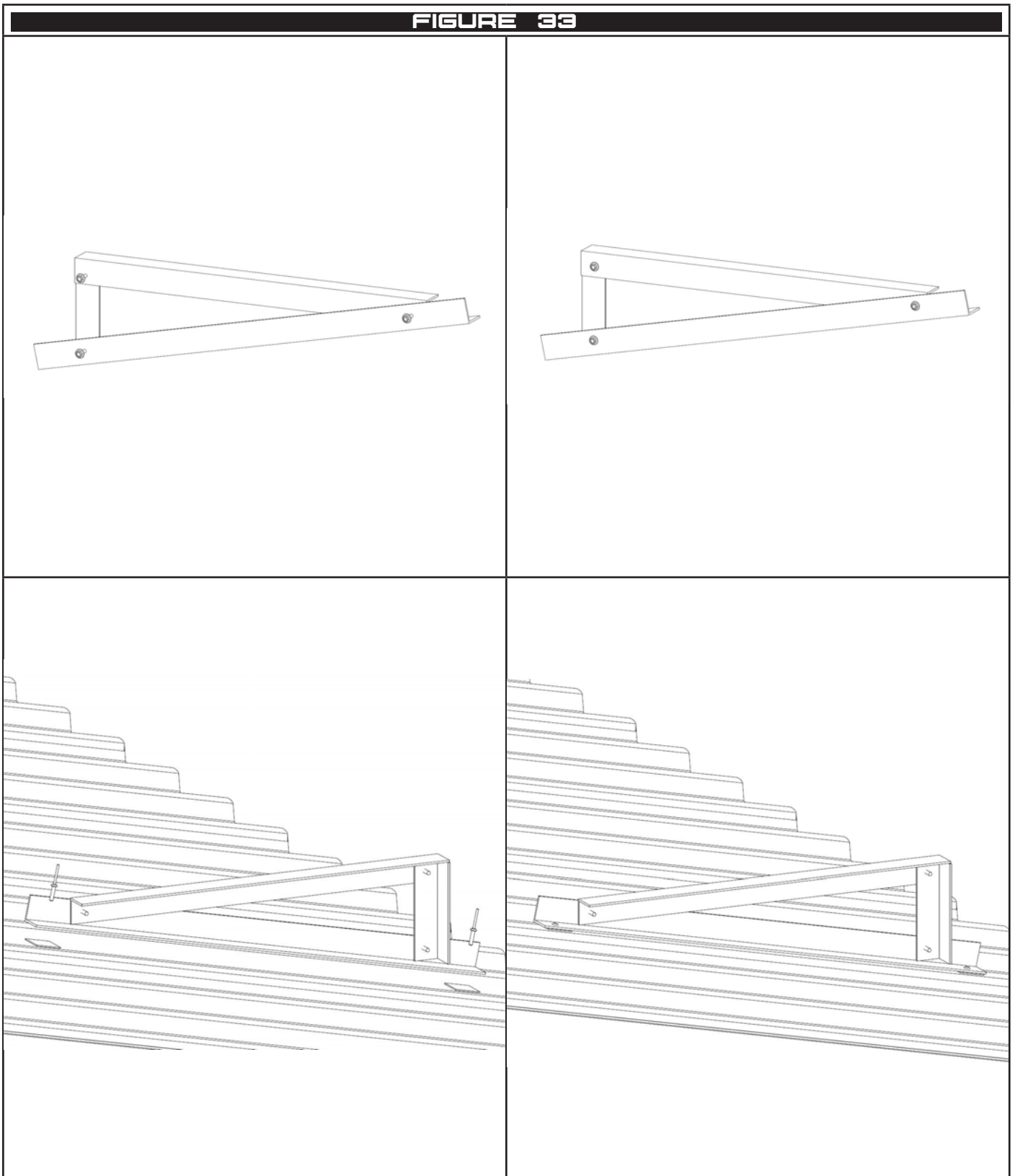

Fix the 3 pieces of angle together with 3x 20mm tek screws. Fix the mesh levelled supports to the roof with 2x 5mm trifold rivets. Ensure that the foam tape is used to prevent compromising the structures waterproofing.

#### 4.4 Single Guardrail Roof Sheet

FIGURE 34

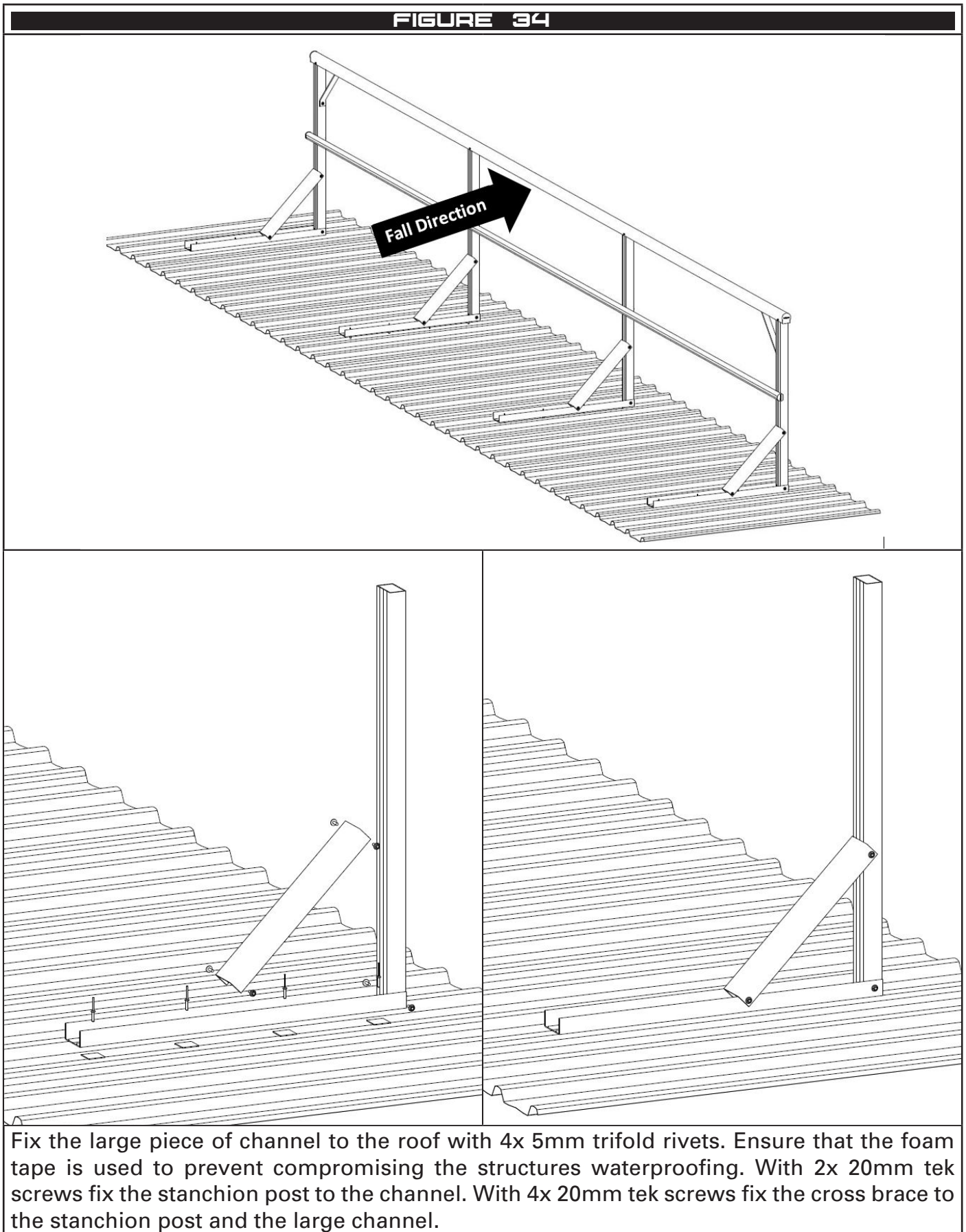

## 4.5 Single Guardrail Concrete Base

**FIGURE 35**

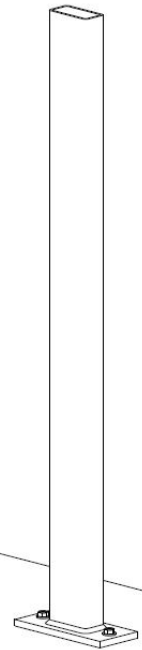
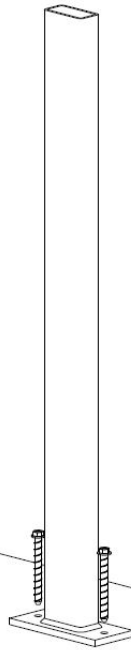
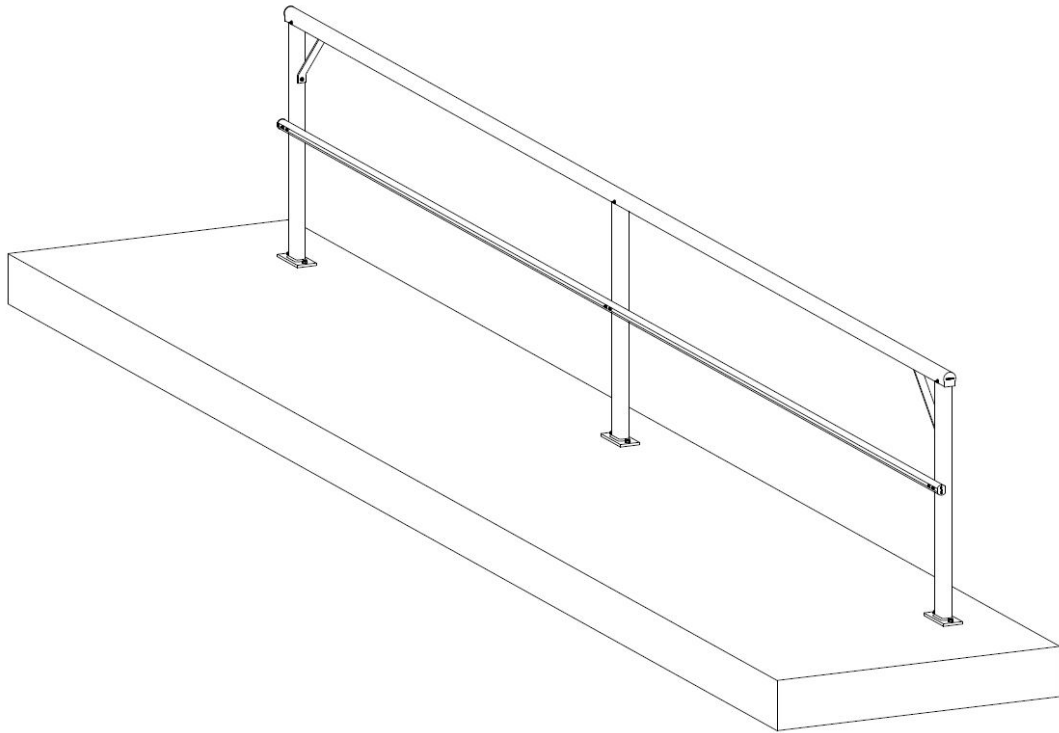

Fix the stanchion to the concrete with 2x fasteners from sections 3.3.6 or 3.3.7.

#### 4.6 Single Guardrail Concrete Side

FIGURE 36

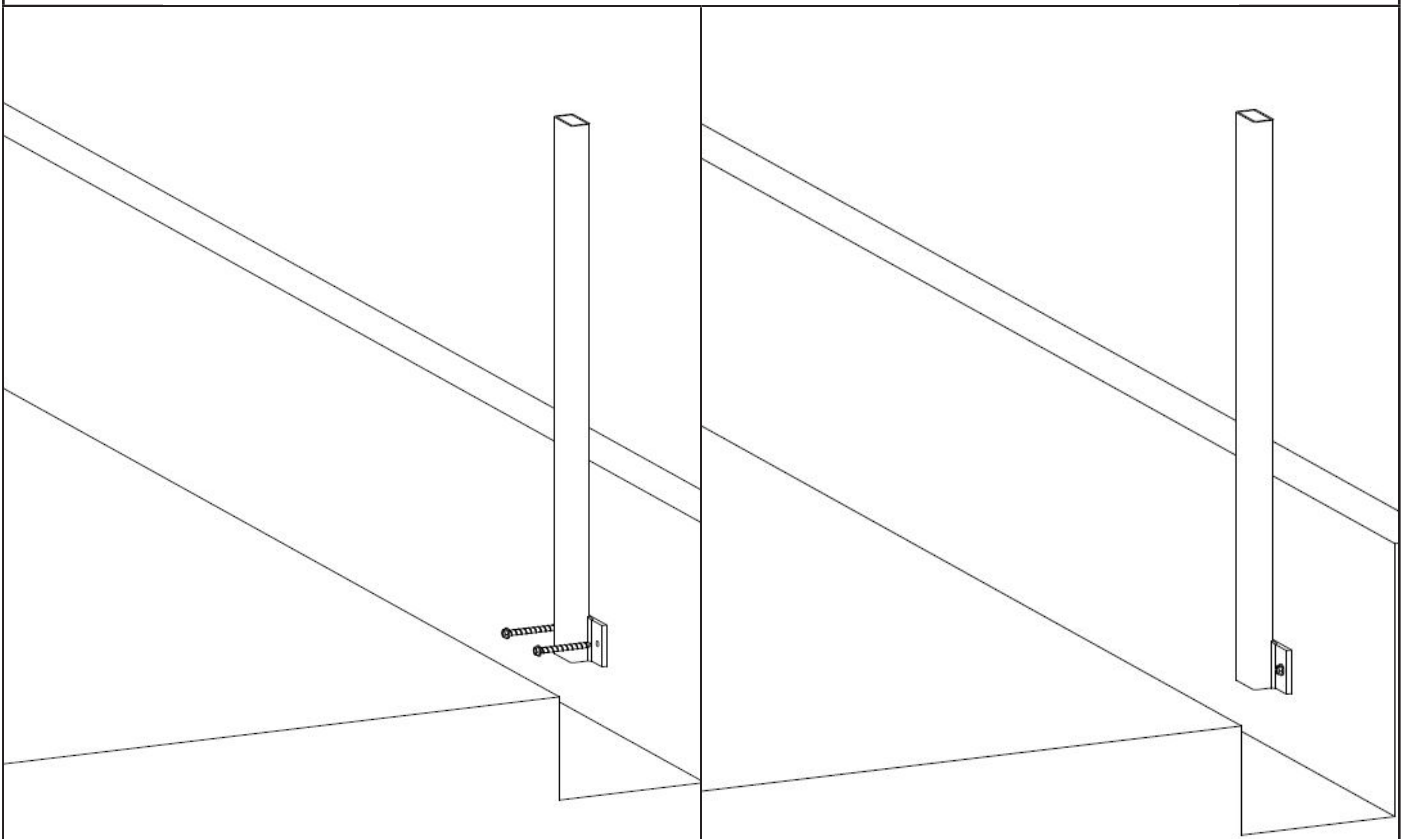
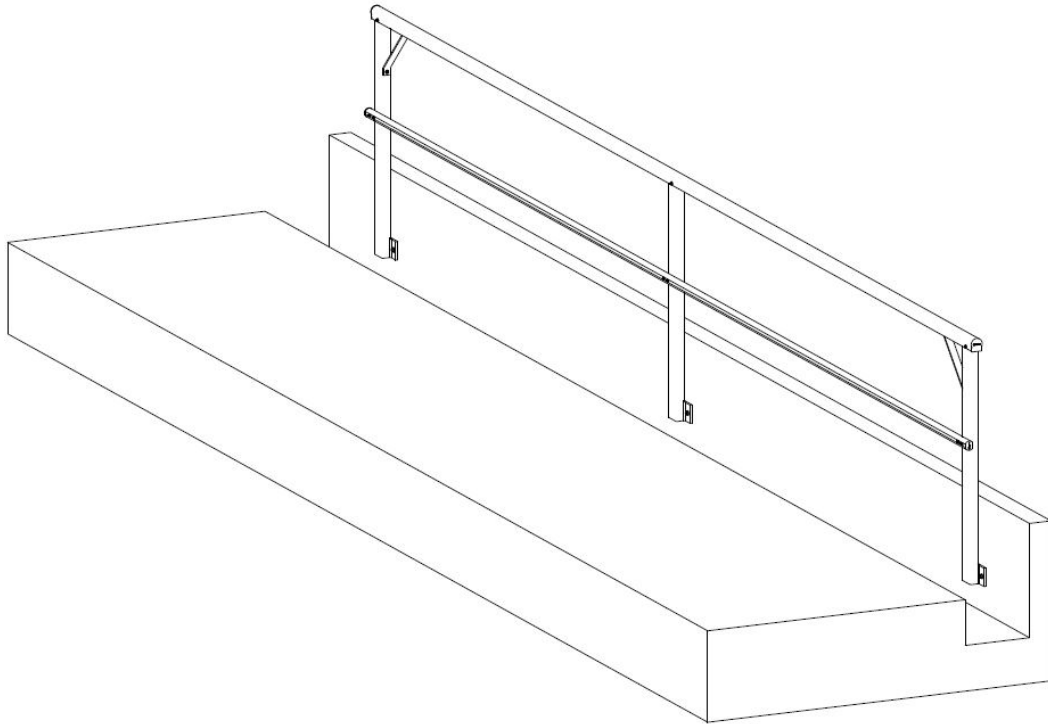

Fix the stanchion to the concrete with 2x fasteners from sections 3.3.6 or 3.3.7.

## 4.7 Fold Down Guardrail for Roof Sheeting

FIGURE 37

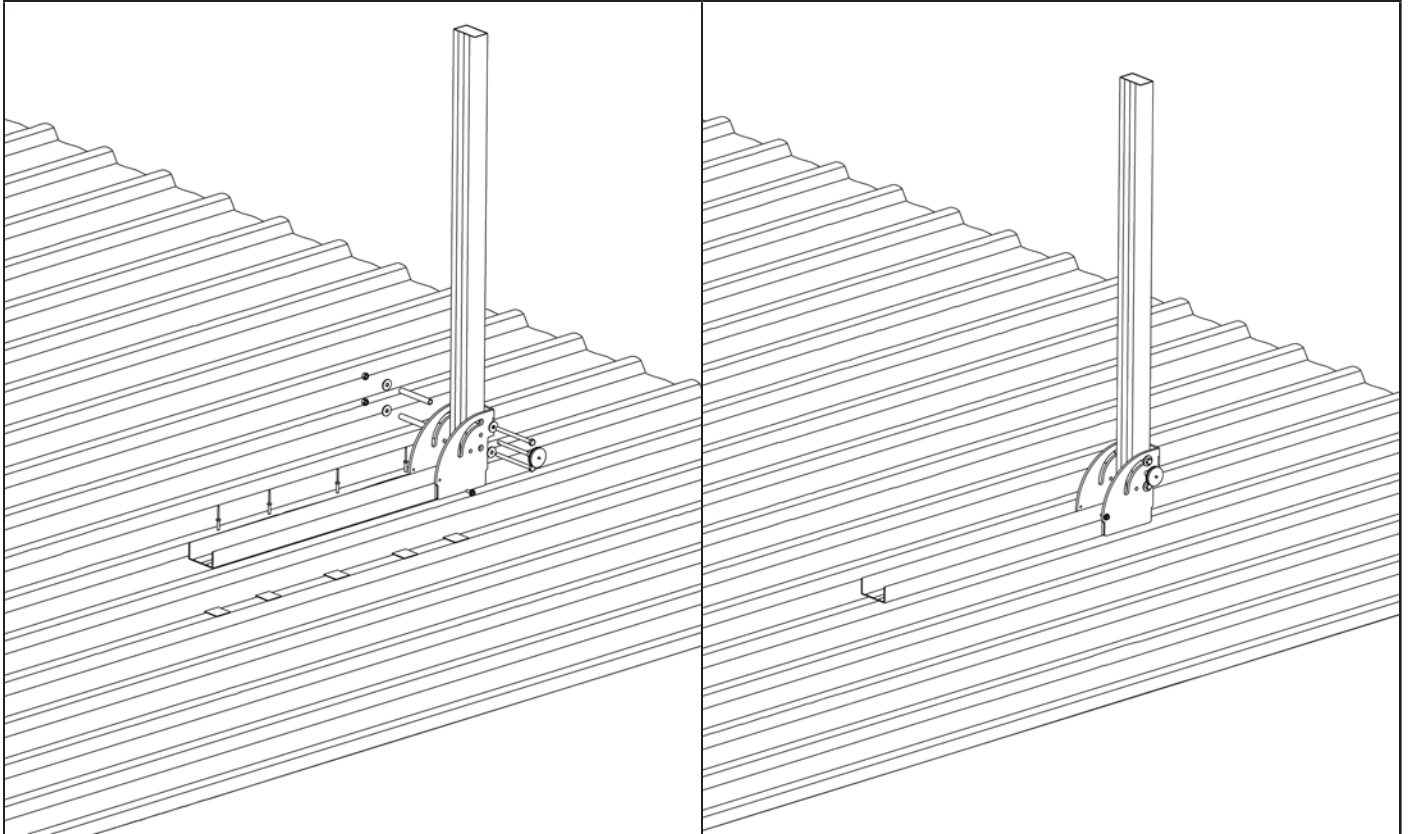
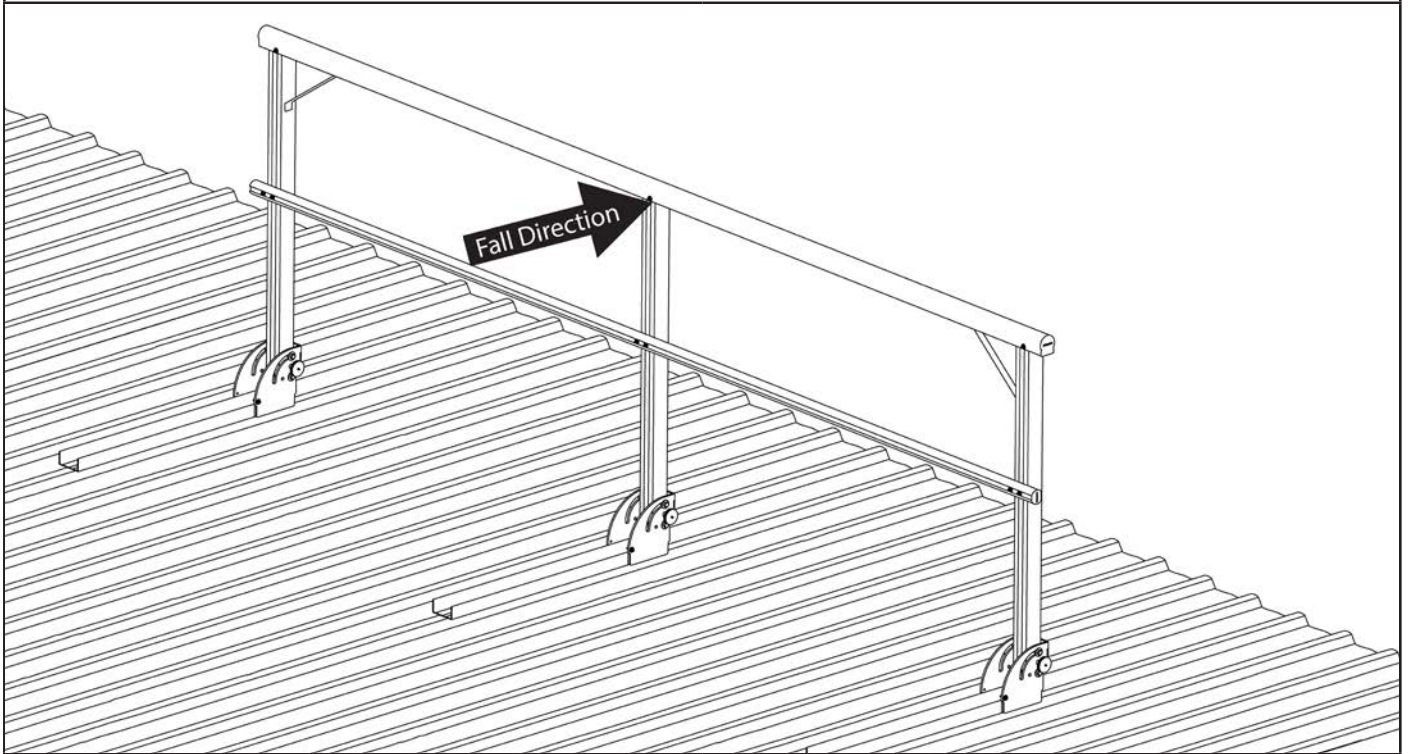

Fix the large piece of channel to the roof with 4x 5mm trifold rivets. Ensure that the foam tape is used to prevent compromising the structures waterproofing. With the supplied bolt, spacer, washers and nuts fasten the stanchion post to the support bracket.

The guardrailing is locked in place (either up or down) by inserting the detent pin.

## 4.8 Fold Guardrail for Concrete

FIGURE 38

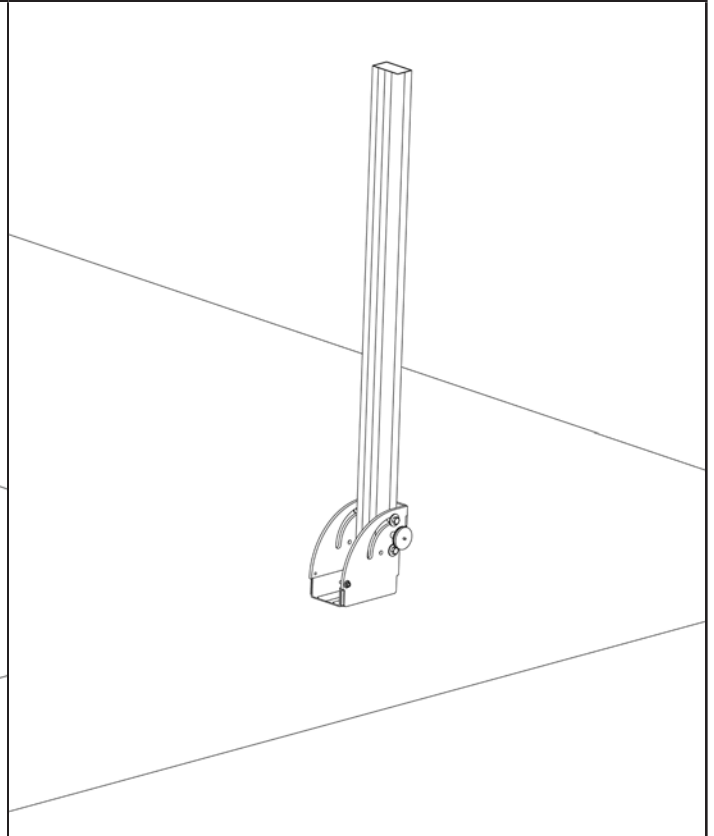
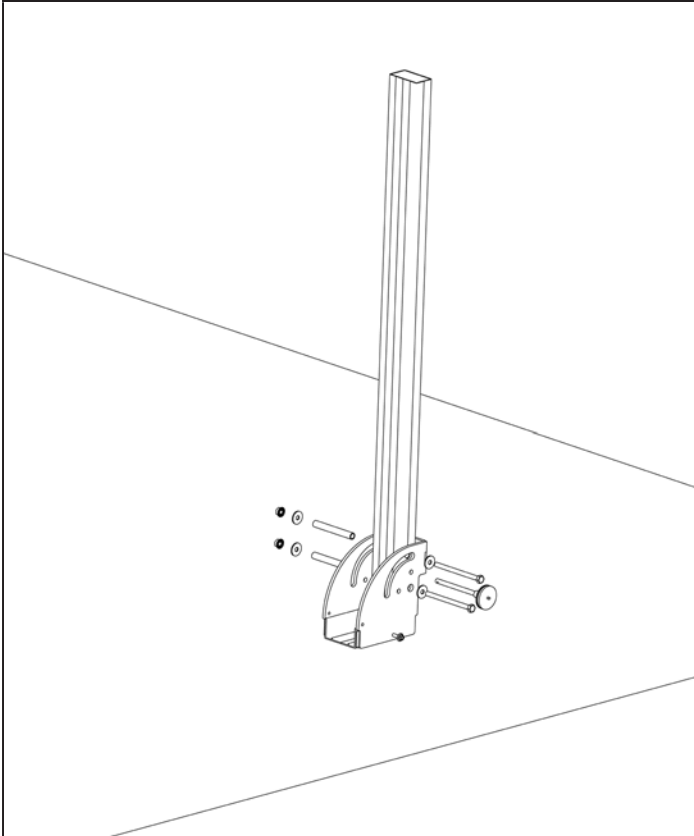
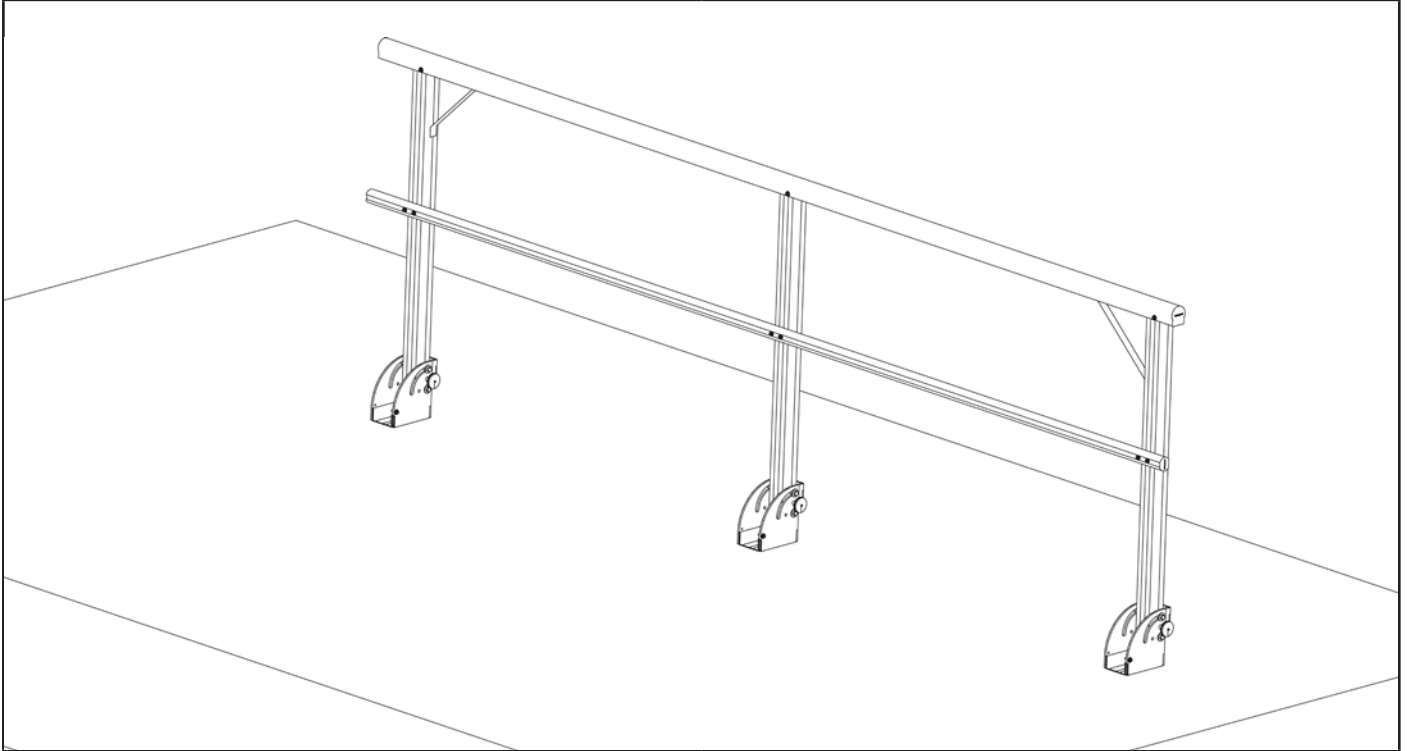

Fix the support bracket to the concrete with 2x fasteners from sections 3.3.6 or 3.3.7. With the supplied bolt, spacer, washers and nuts fasten the stanchion post to the support bracket.

The guardrailing is locked in place (either up or down) by inserting the detent pin.

#### 4.9 Single Guardrail with Walkway

FIGURE 39

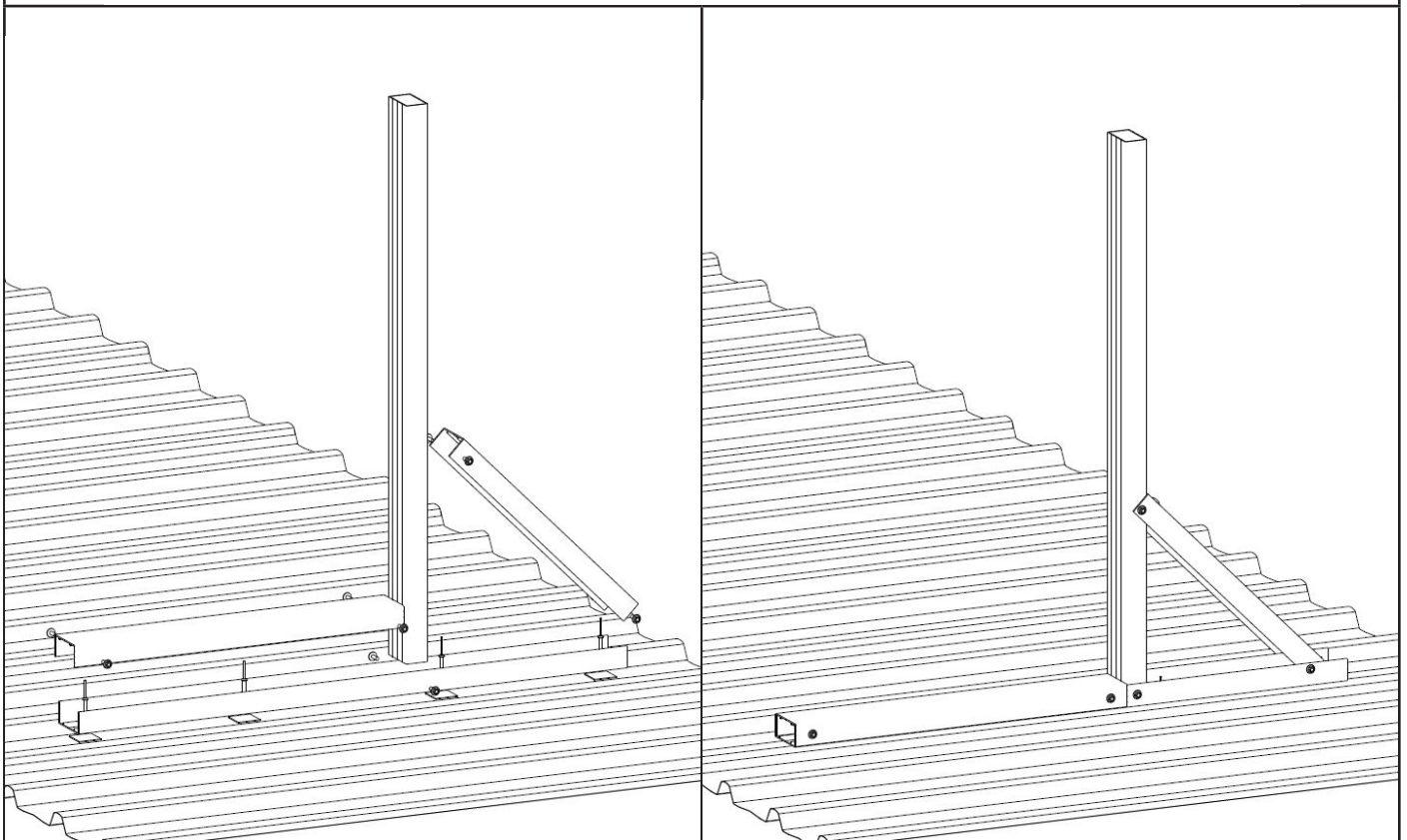
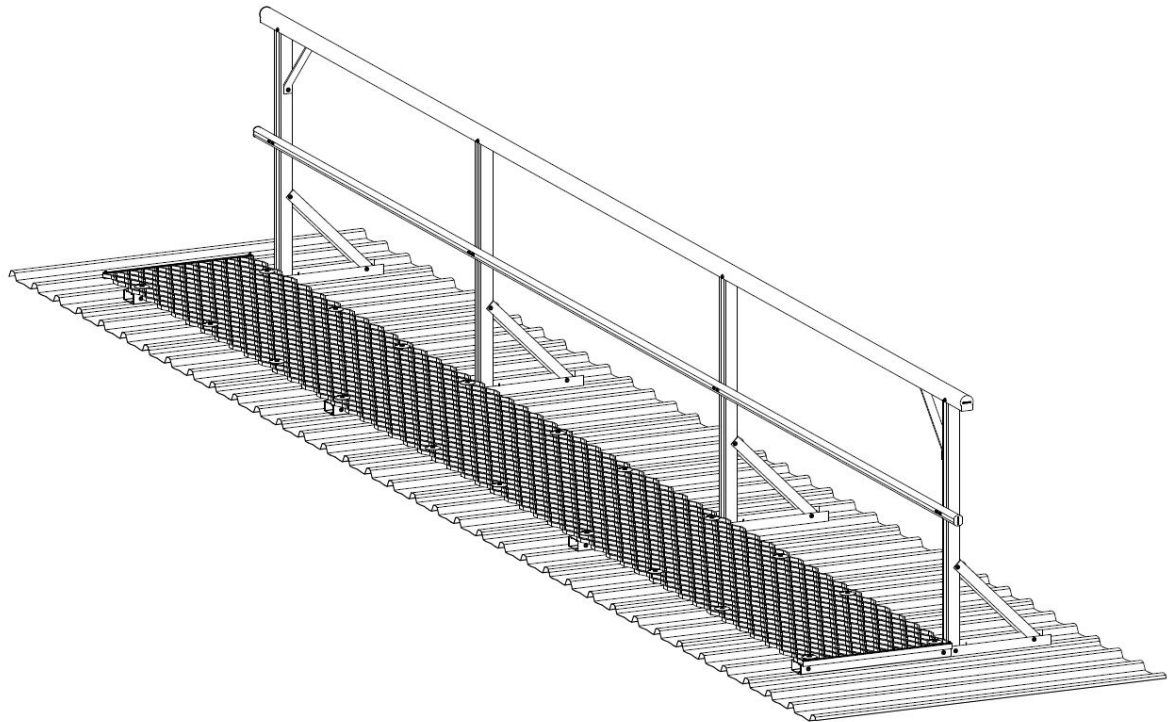

Fix the large piece of channel to the roof with 4x 5mm trifold rivets. Ensure that the foam tape is used to prevent compromising the structures waterproofing. With 2x 20mm tek screws fix the stanchion post to the channel. With 4x 20mm tek screws fix the cross brace to the stanchion post and the large channel. Finally fix the mesh support channel to the larger channel with 4x 20mm tek screws.

#### 4.10 Single Guardrail with Levelled Walkway

FIGURE 40

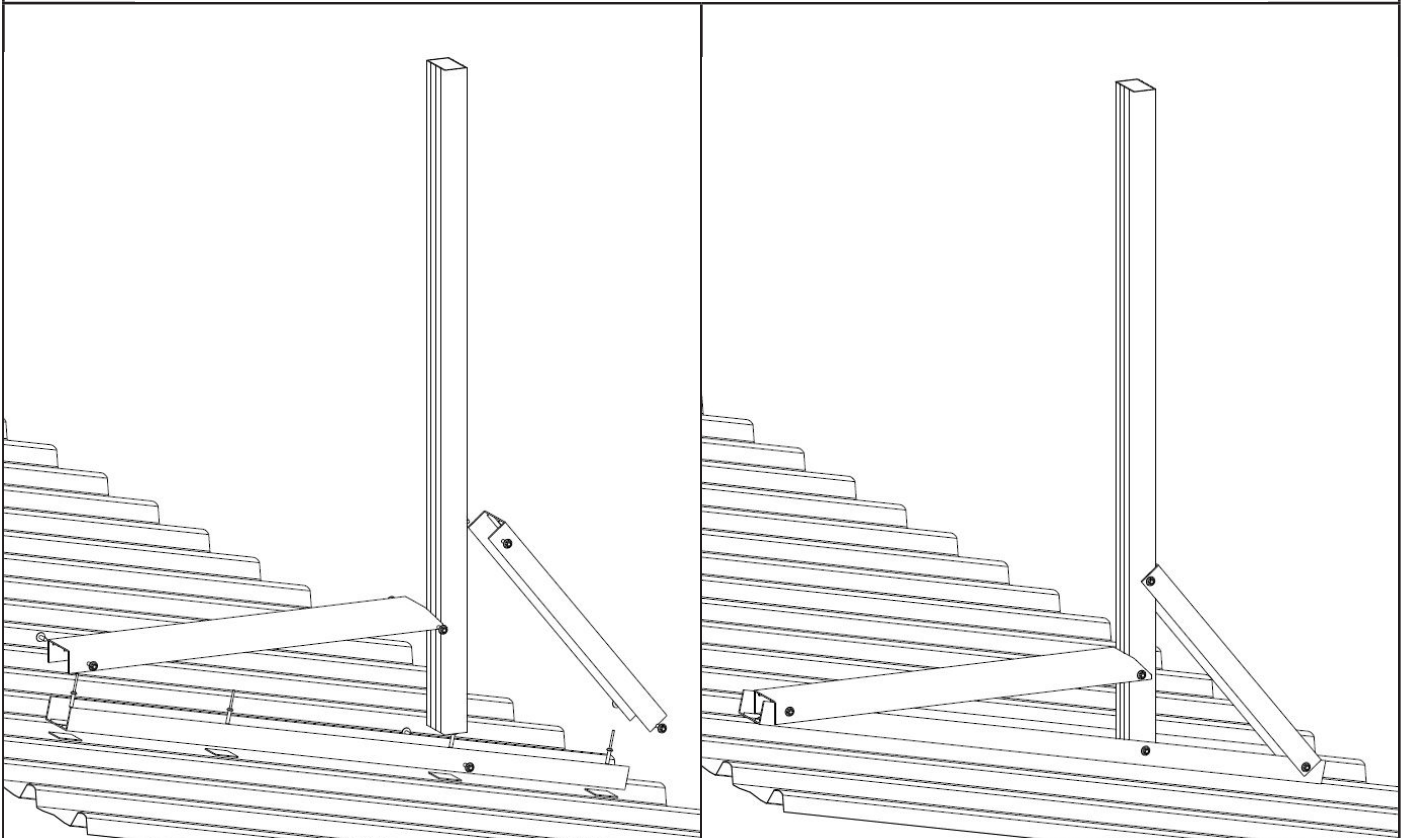
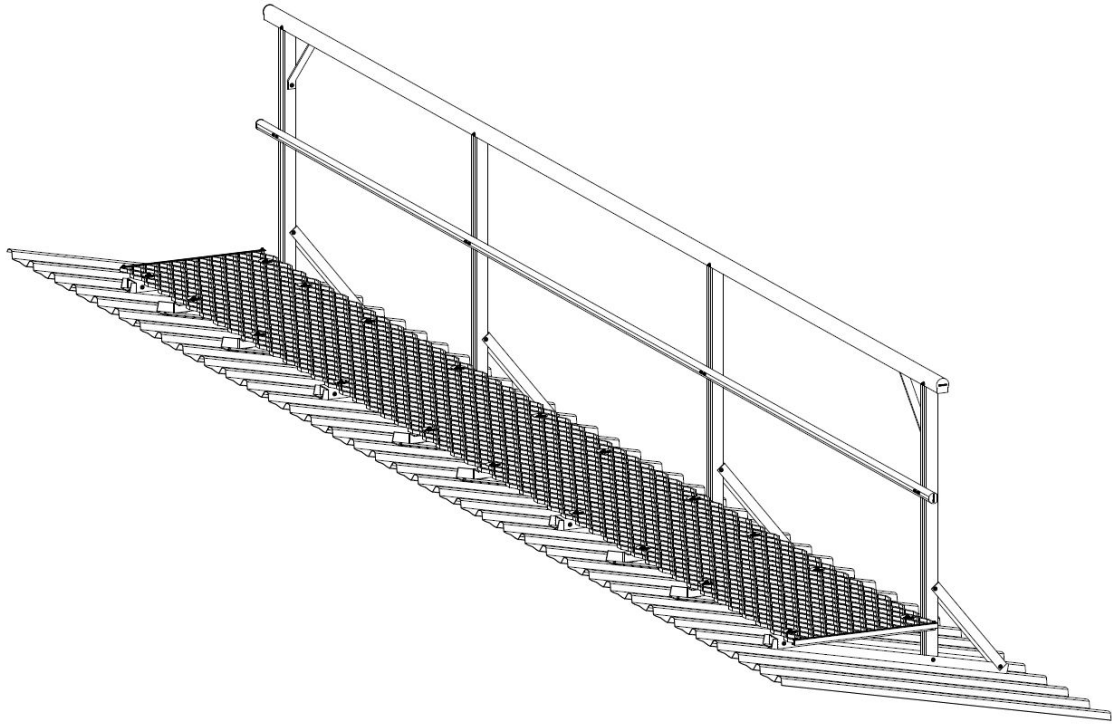

Fix the large piece of channel to the roof with 4x 5mm trifold rivets. Ensure that the foam tape is used to prevent compromising the structures waterproofing. With 2x 20mm tek screws fix the stanchion post to the channel. With 4x 20mm tek screws fix the cross brace to the stanchion post and the large channel. Finally fix the mesh support channel to the larger channel with 2x 20mm tek screws and to the stanchion post with 2x 20mm tek screws.

#### 4.11 Twin Guardrail with Walkway

FIGURE 41

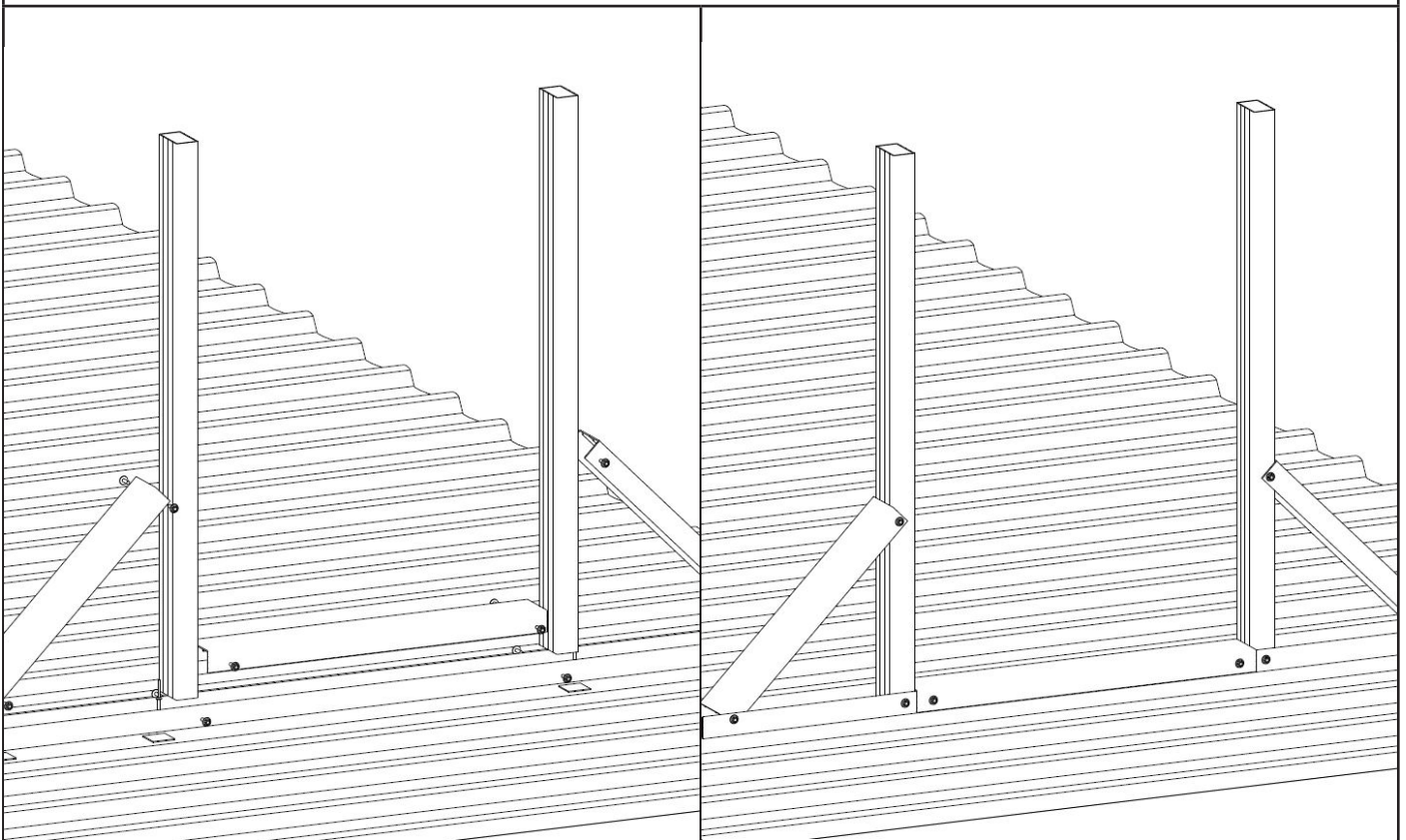
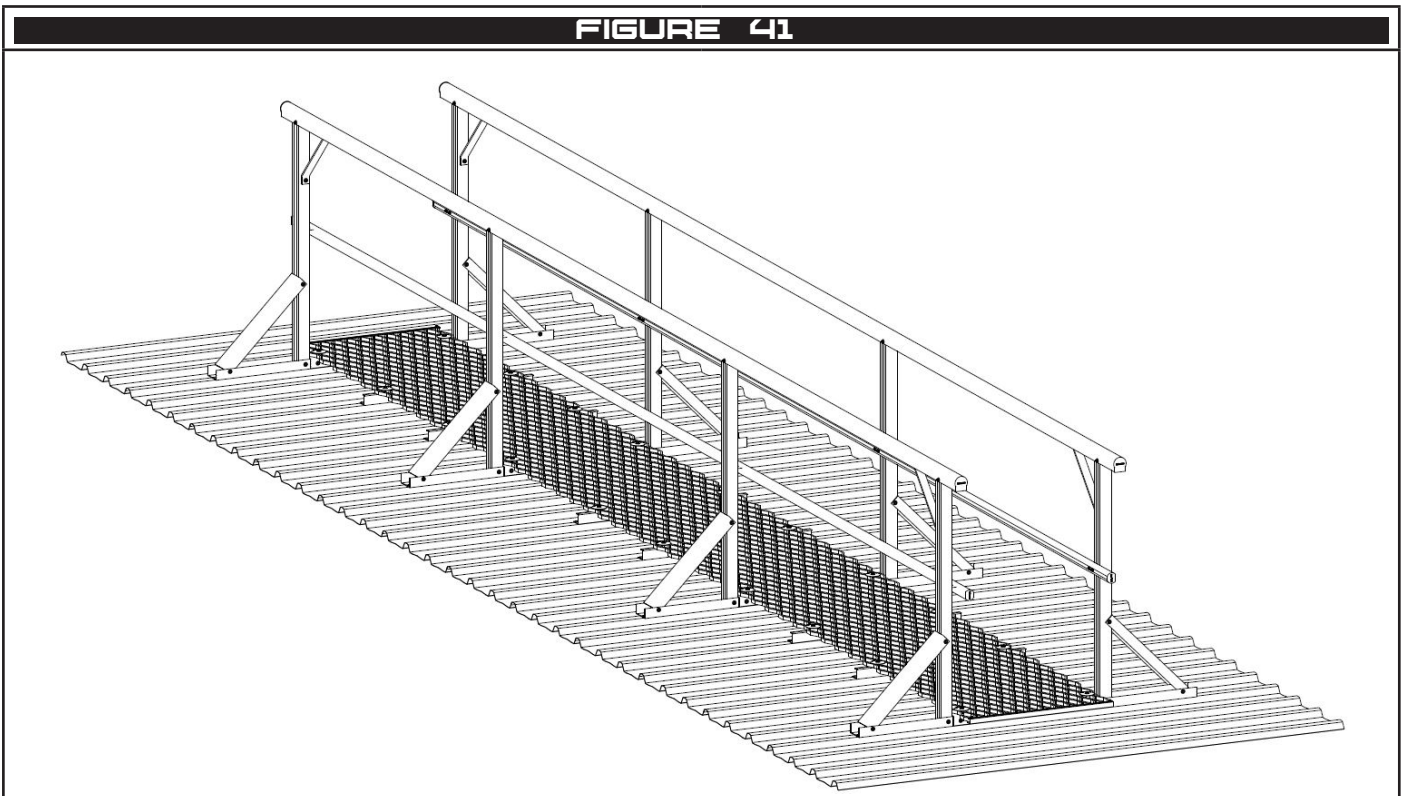

Fix the large piece of channel to the roof with 4x 5mm trifold rivets. Ensure that the foam tape is used to prevent compromising the structures waterproofing. With 2x 20mm tek screws fix each stanchion post to the channel. With 4x 20mm tek screws fix each cross brace to the stanchion post and the large channel. Finally fix the mesh support channel to the larger channel with 4x 20mm tek screws.

## 4.12 Twin Guardrail with Levelled Walkway

FIGURE 42

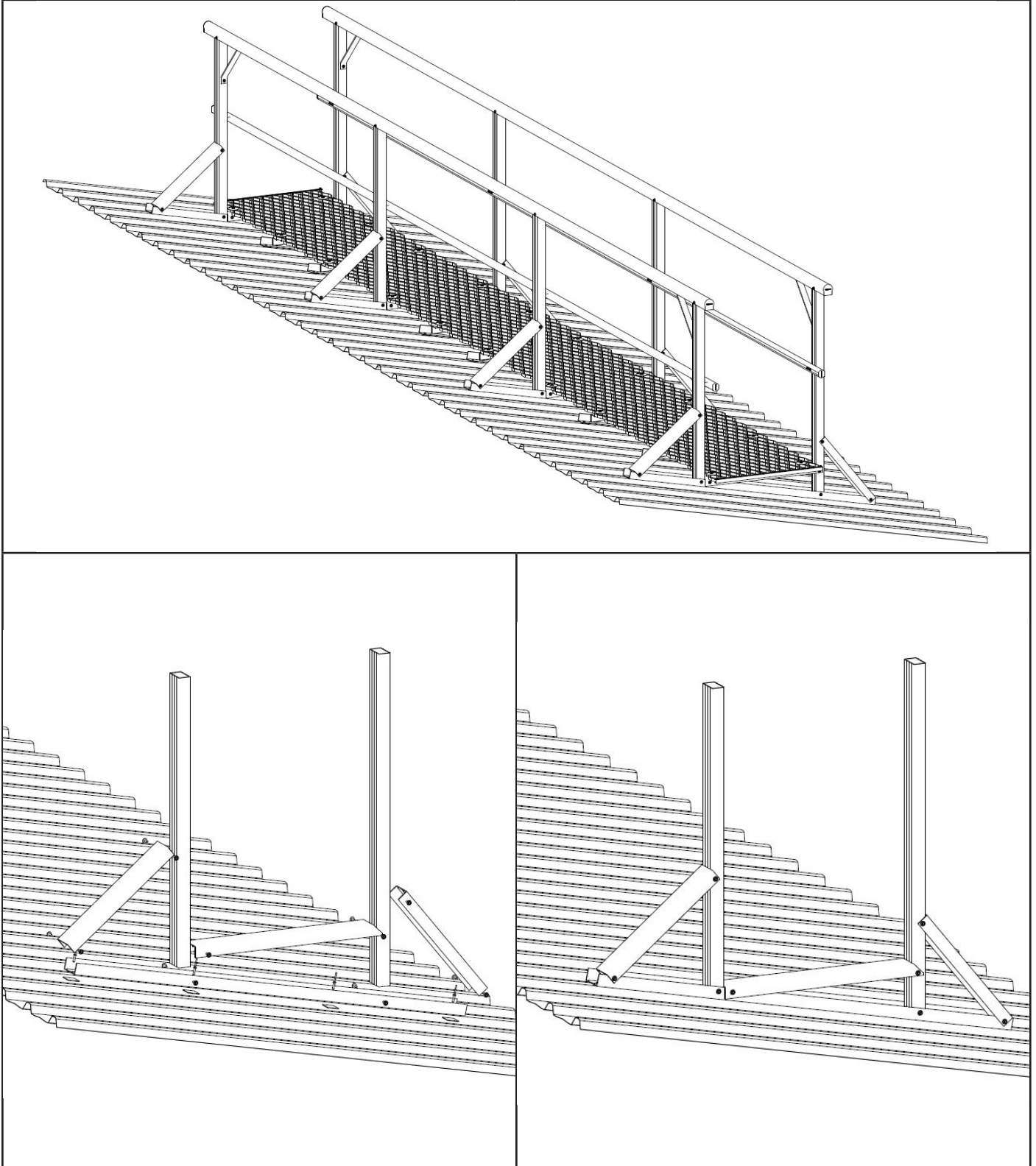

Fix the large piece of channel to the roof with 4x 5mm trifold rivets. Ensure that the foam tape is used to prevent compromising the structures waterproofing. With 2x 20mm tek screws fix each stanchion post to the channel. With 4x 20mm tek screws fix each cross brace to the stanchion post and the large channel. Finally fix the mesh support channel to the larger channel with 2x 20mm tek screws and to the stanchion post with 2x 20mm tek screws.

## 5 Component Assembly

### 5.1 Guardrails

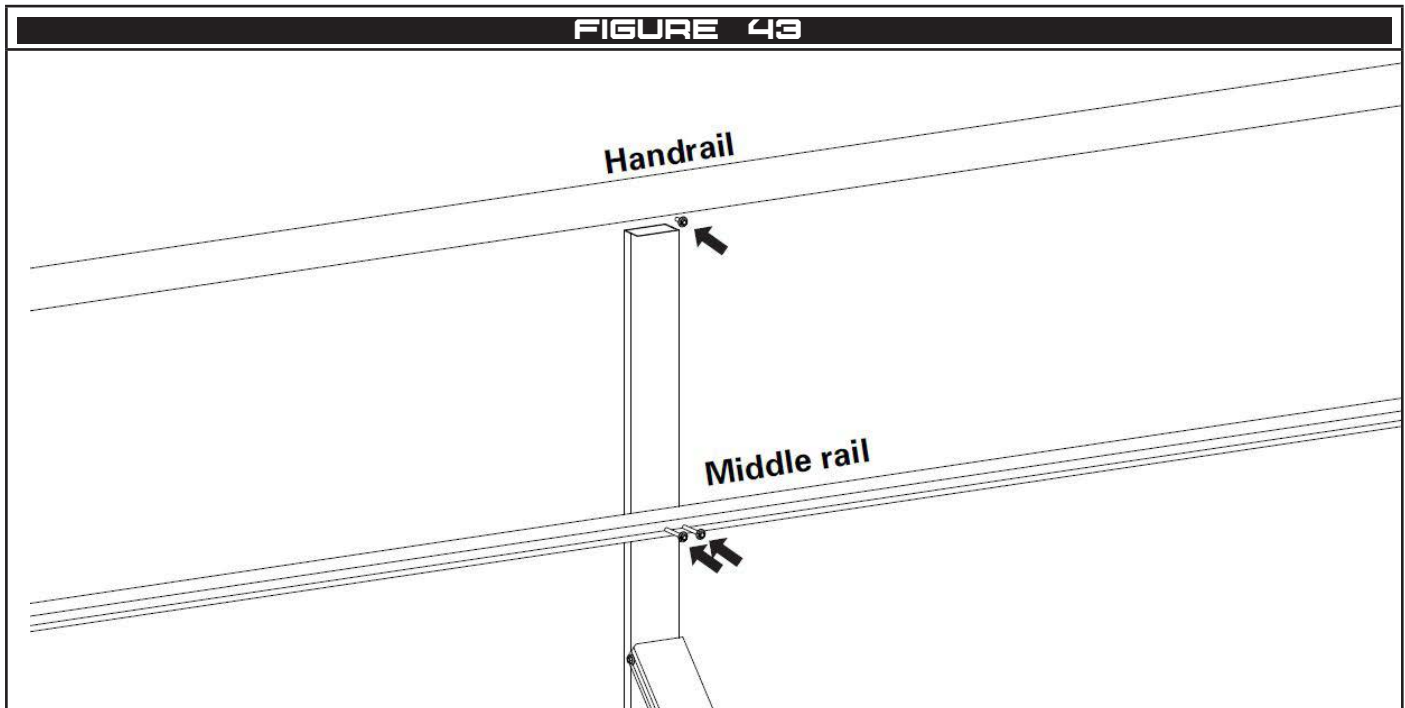

The handrail shall be fixed to each stanchion with 2x 20mm tek screws, one in each side of the stanchion. All middle rails shall be fixed with 2x 50mm tek screws in to each stanchion. The 2 tek screws shall be installed from the same side, through the centre of the middle rail.

### 5.2 Guardrail Joins

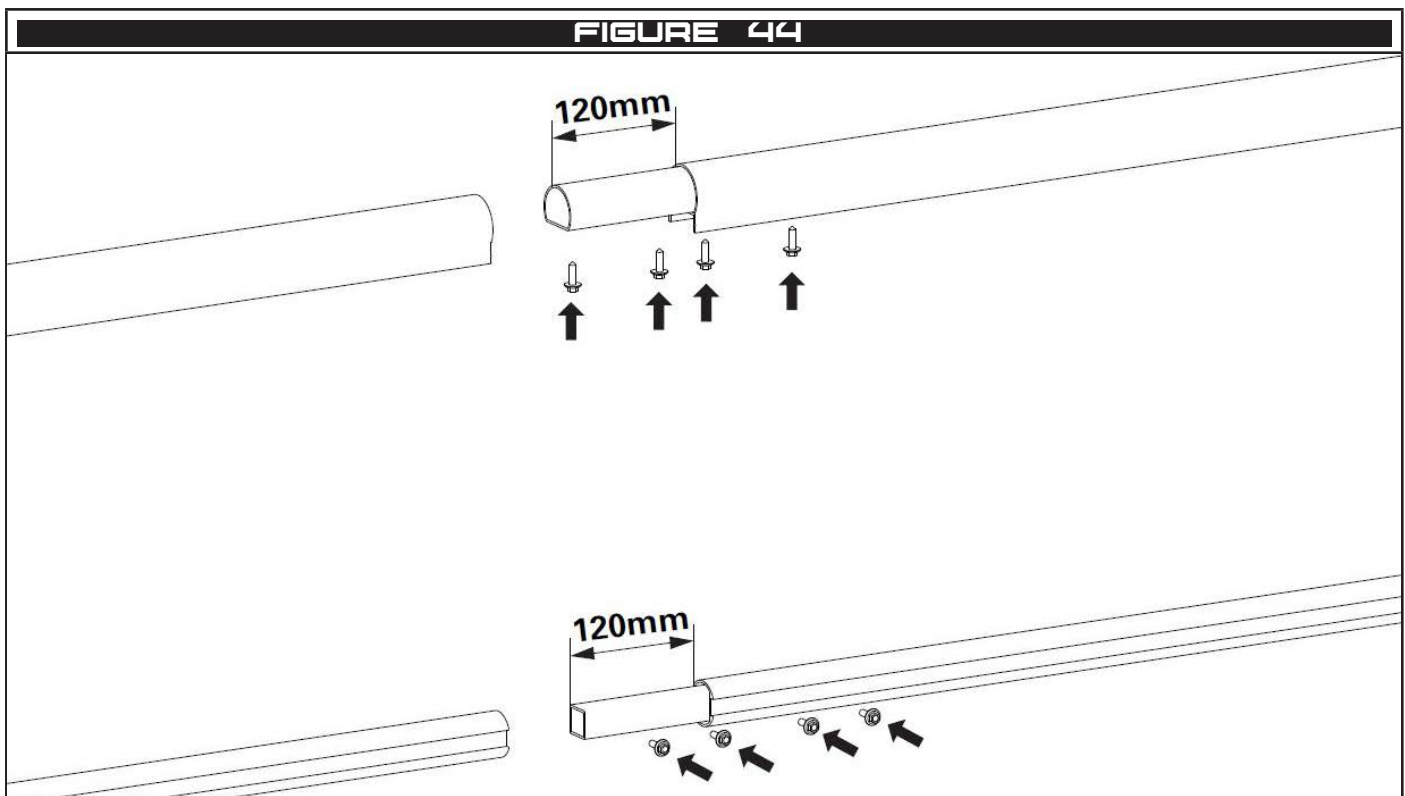

When joining handrails and middle rails, insert the appropriate slice piece half way in to the profile and fix with 2x 20mm tek screws. Slide the next length of rail over the exposed part of slice and fix with 2x 20mm tek screws. Handrail screws shall be installed from underneath. Middle rail screws shall be installed in the side.

### 5.3 Brace

FIGURE 45

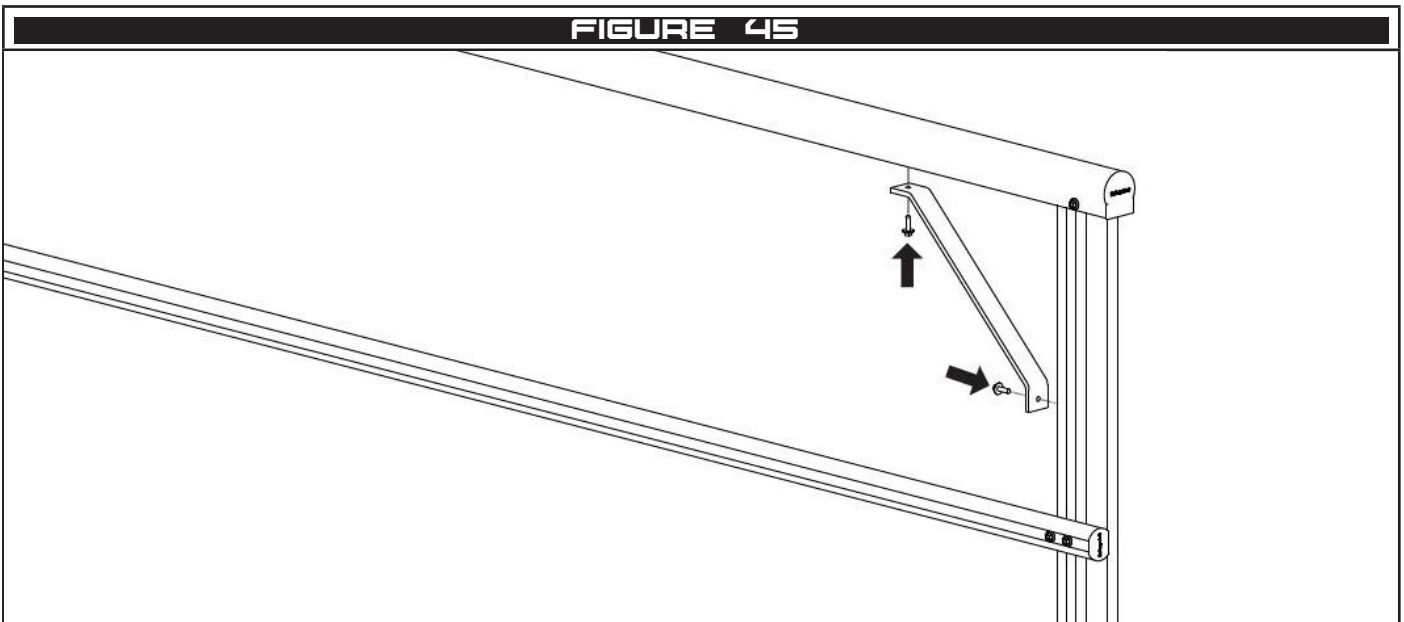

Braces shall be installed with 2x 20mm tek screws. One in to the handrail profile from underneath, the other in to the side of the stanchion. Braces shall be installed at the ends of the guardrail

### 5.4 Mesh Fastening

FIGURE 46

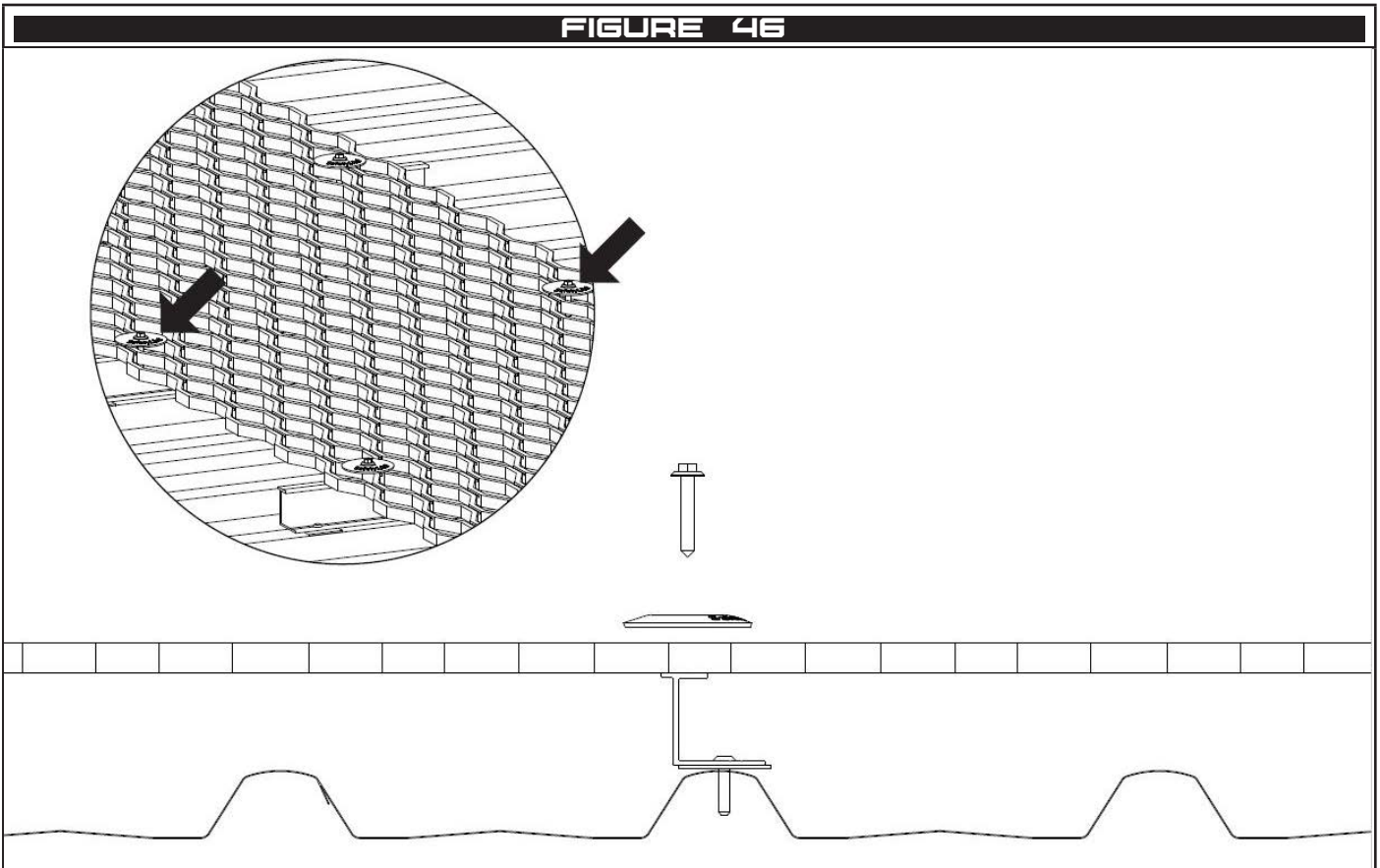

Walkway mesh shall be fixed with 2x 35mm tek screws in to each mesh support batten. Each screw shall be installed with a 50mm aluminium walkway mesh washer.

## 5.5 Mesh Joins

FIGURE 47

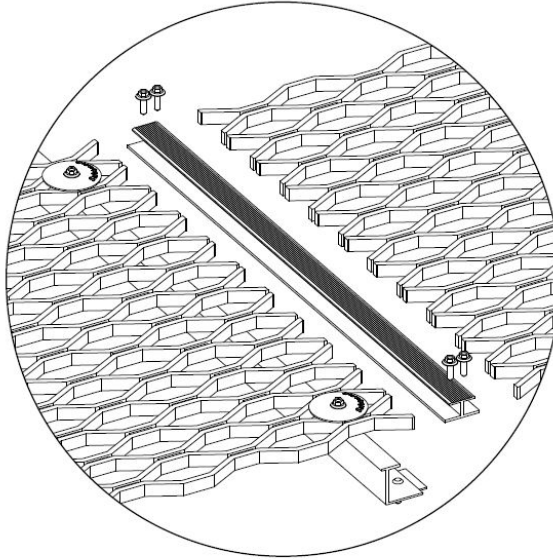

When joining 2 sheets of walkway mesh, the joiner bar shall be installed with 2x 20mm tek screws in to each piece of mesh.

## 5.6 Mesh Ends

FIGURE 48

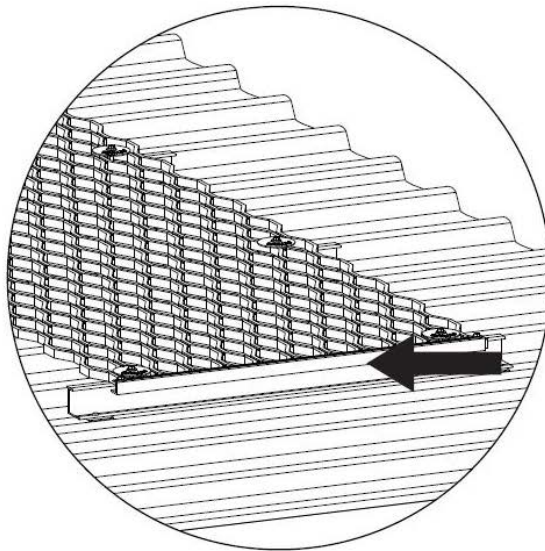

The end of a sheet of walkway mesh shall be cap with an end bar. The end bar shall be fix with 2x 20mm tek screws.

If the end of the mesh represents a change in levels, the end bar shall be yellow.

## 5.7 Rail Corners

FIGURE 49

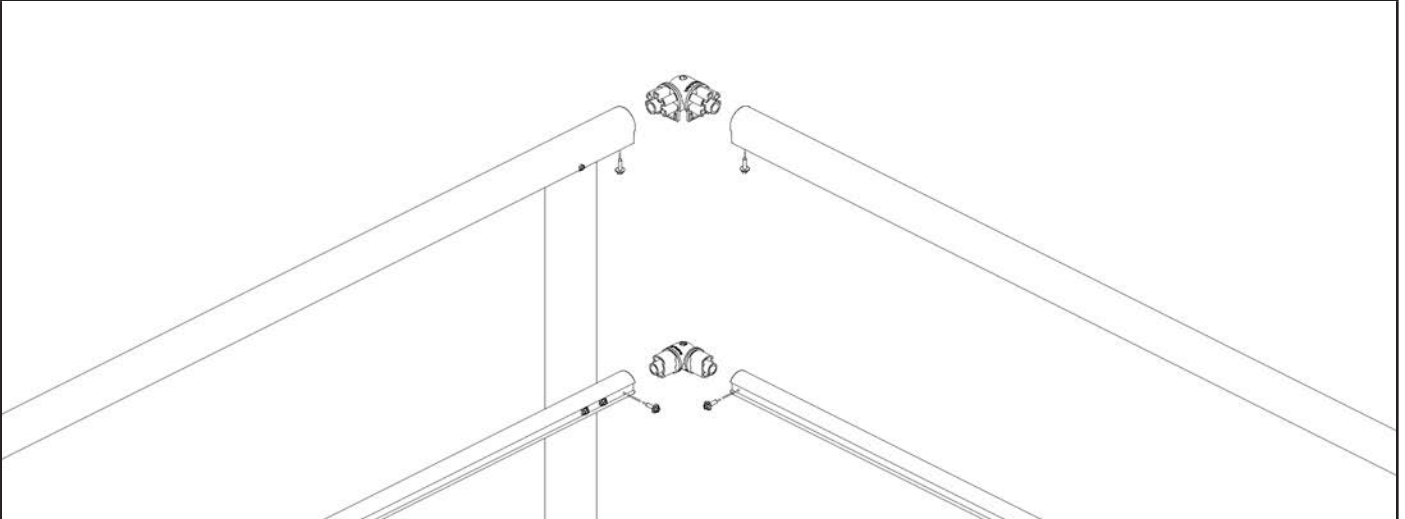

Install the rail corners with a 20mm tek screw in each side. Handrail screws shall be installed from underneath. Middle rail screws shall be installed in the side.

## 5.8 Rail Caps

FIGURE 50

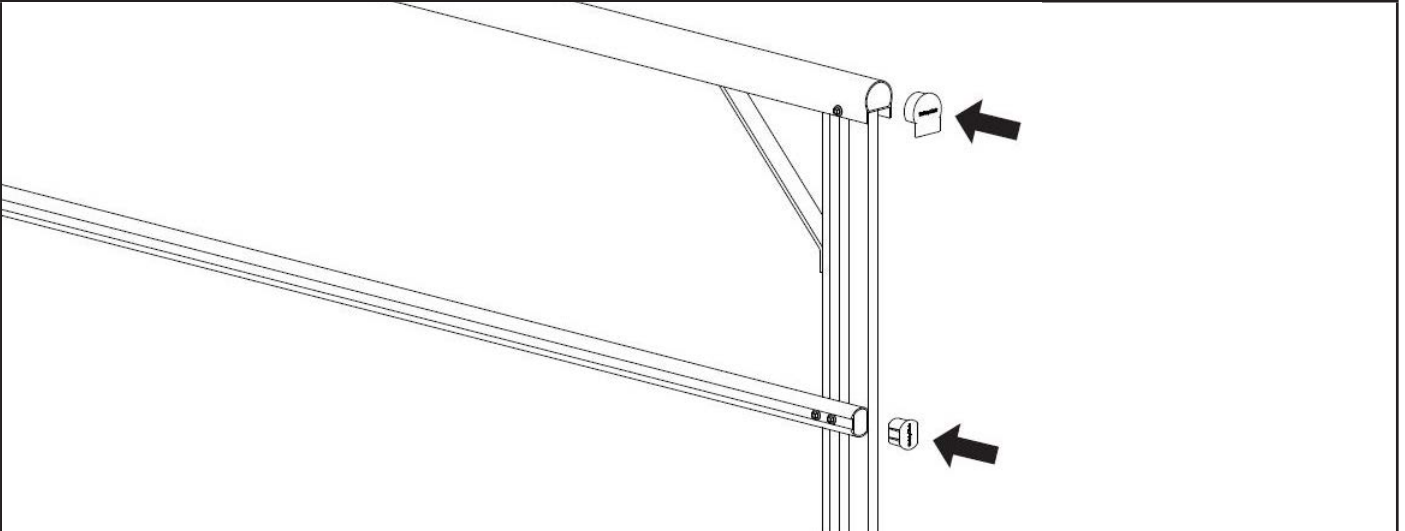

Install end caps with a rubber mallet.

## 5.9 Cleats

FIGURE 51

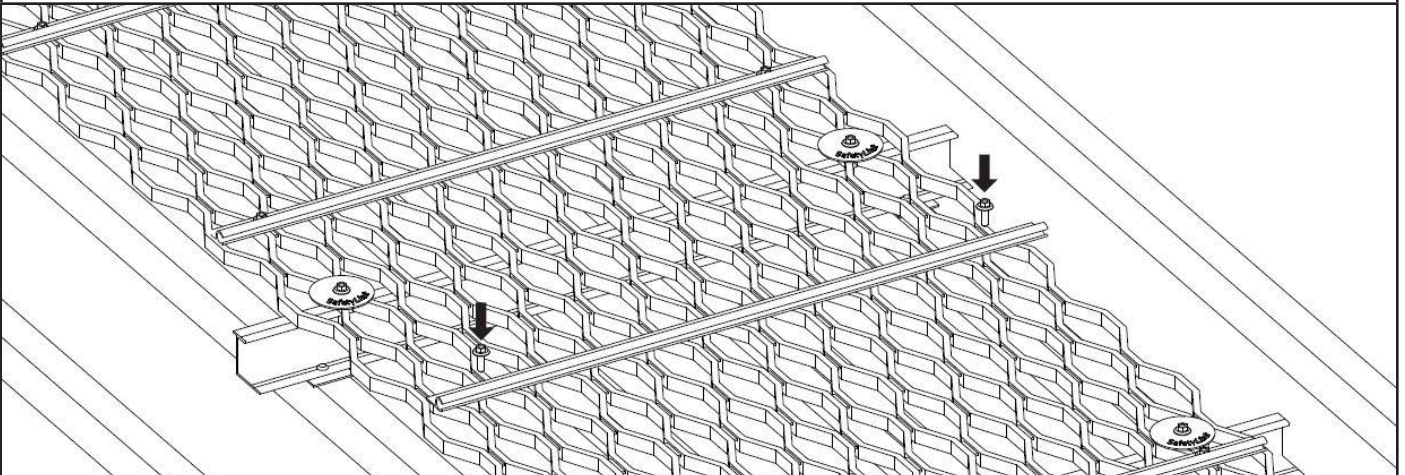

Cleats shall be fixed with 2x 20mm tek screws.

## 5.10 Toeboard

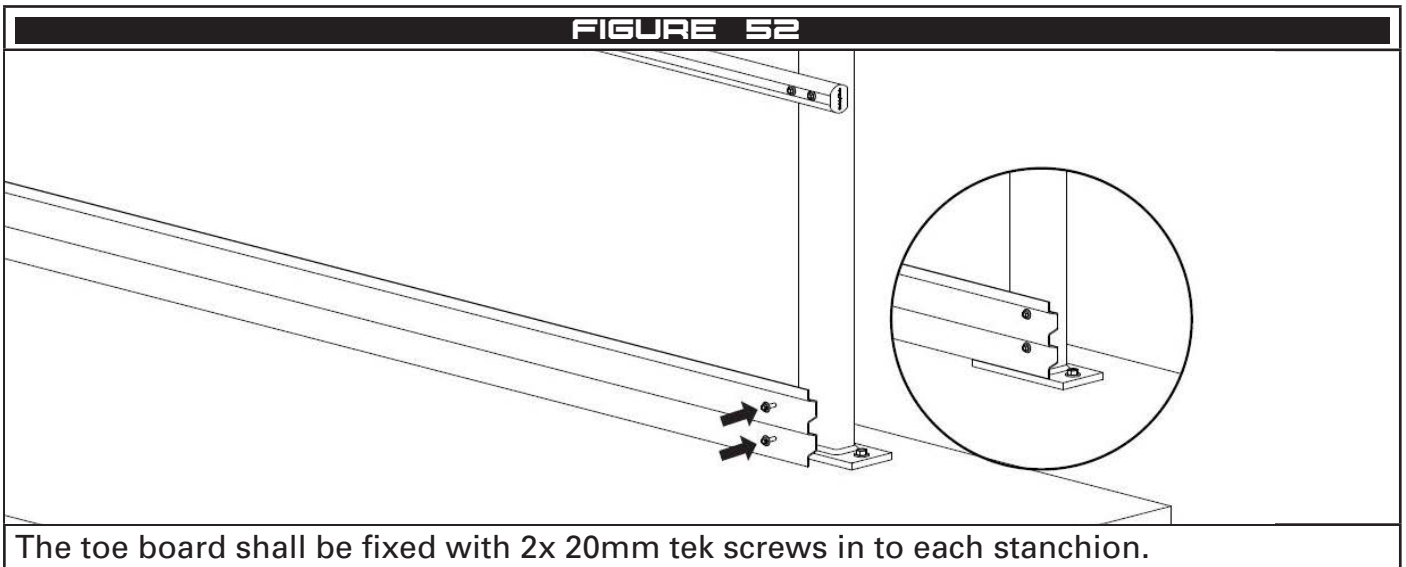

## 5.11 Toeboard Join

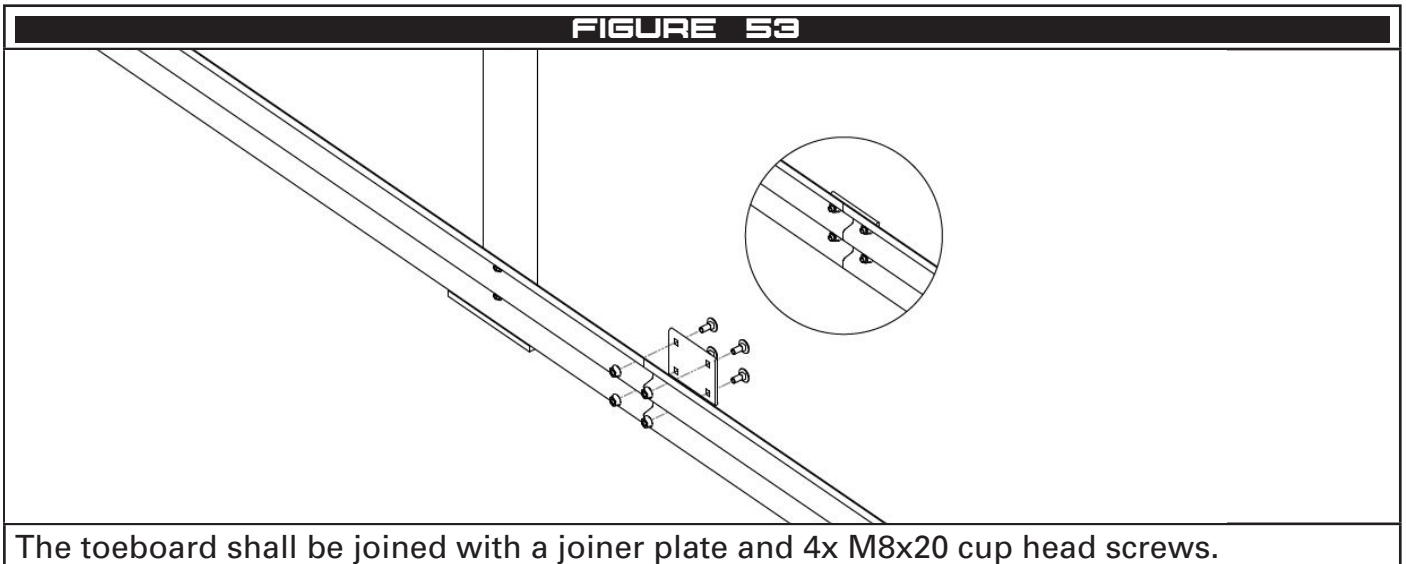

## 5.12 Toeboard Corner

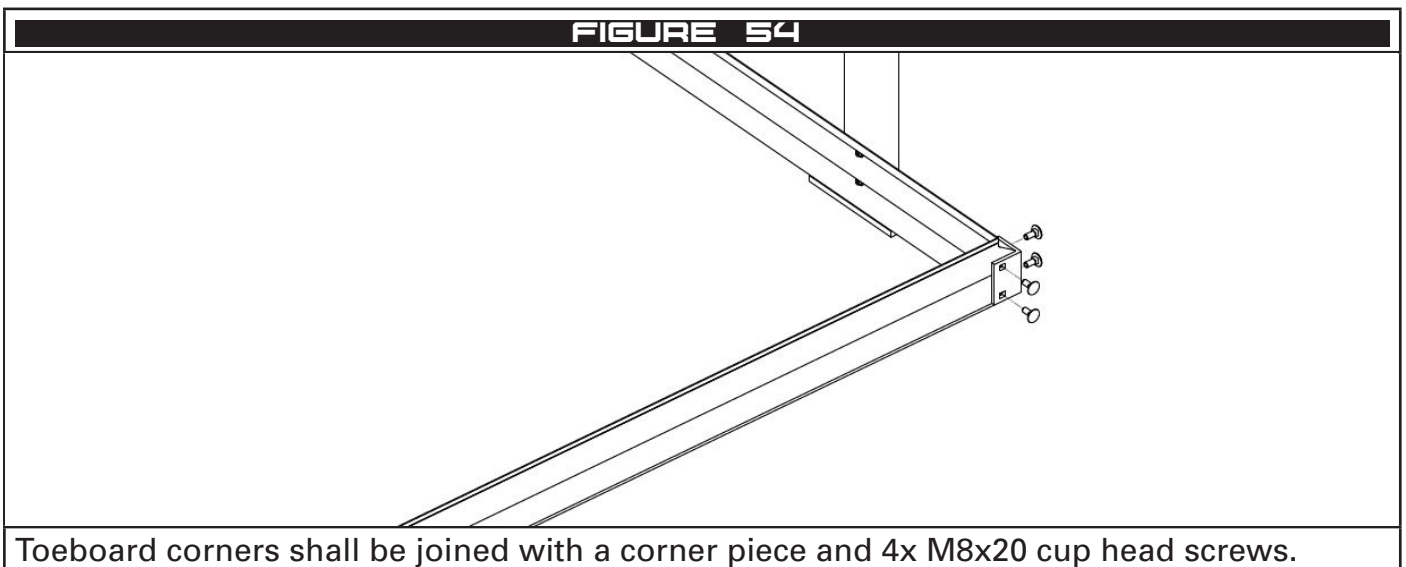

## 6 Corner Kits

### 6.1 Kit 1

#### 6.1.1 Single Guardrail Corner (Flat Roof)

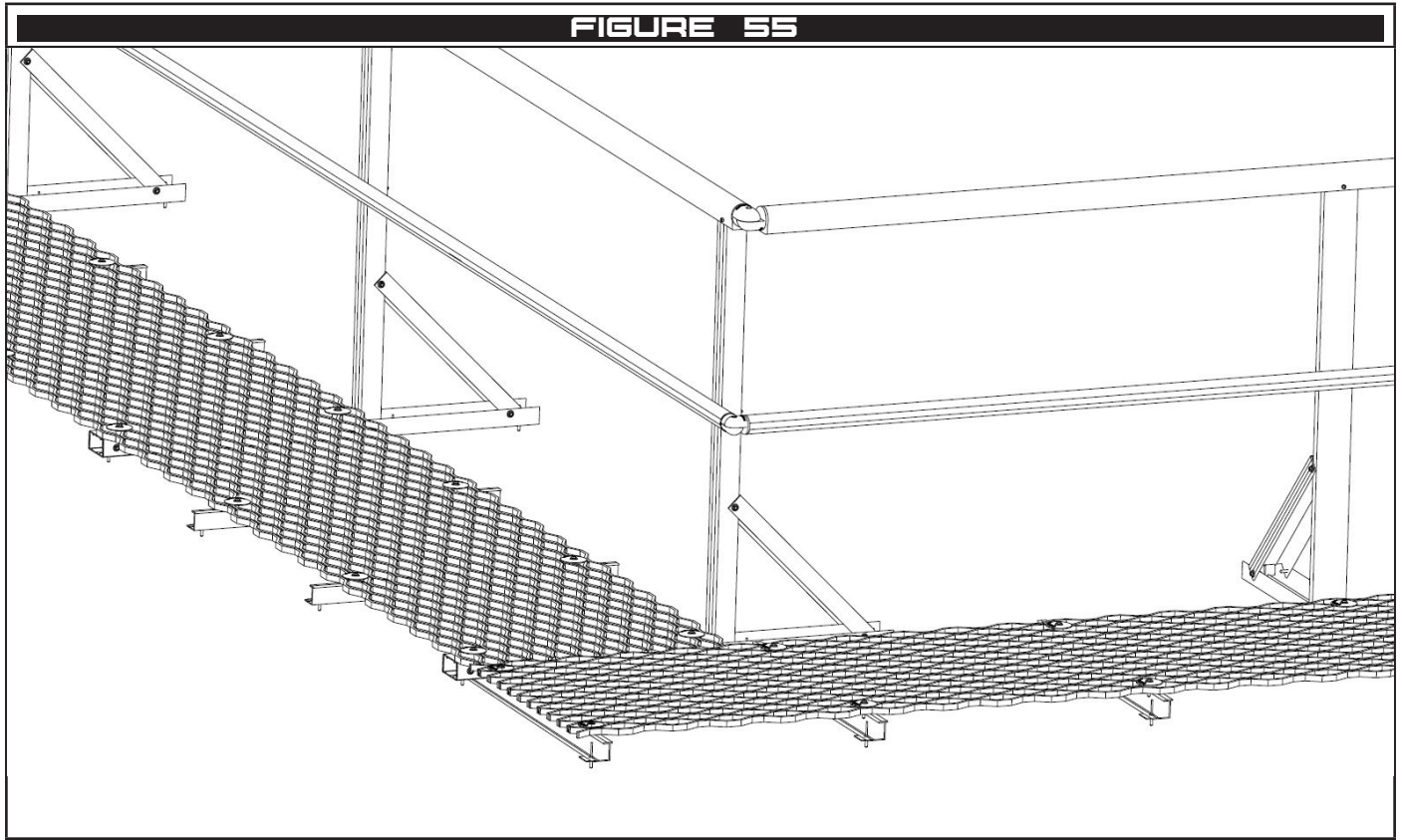

#### 6.1.2 Double Guardrail to Single Guardrail Corner (Flat Roof)

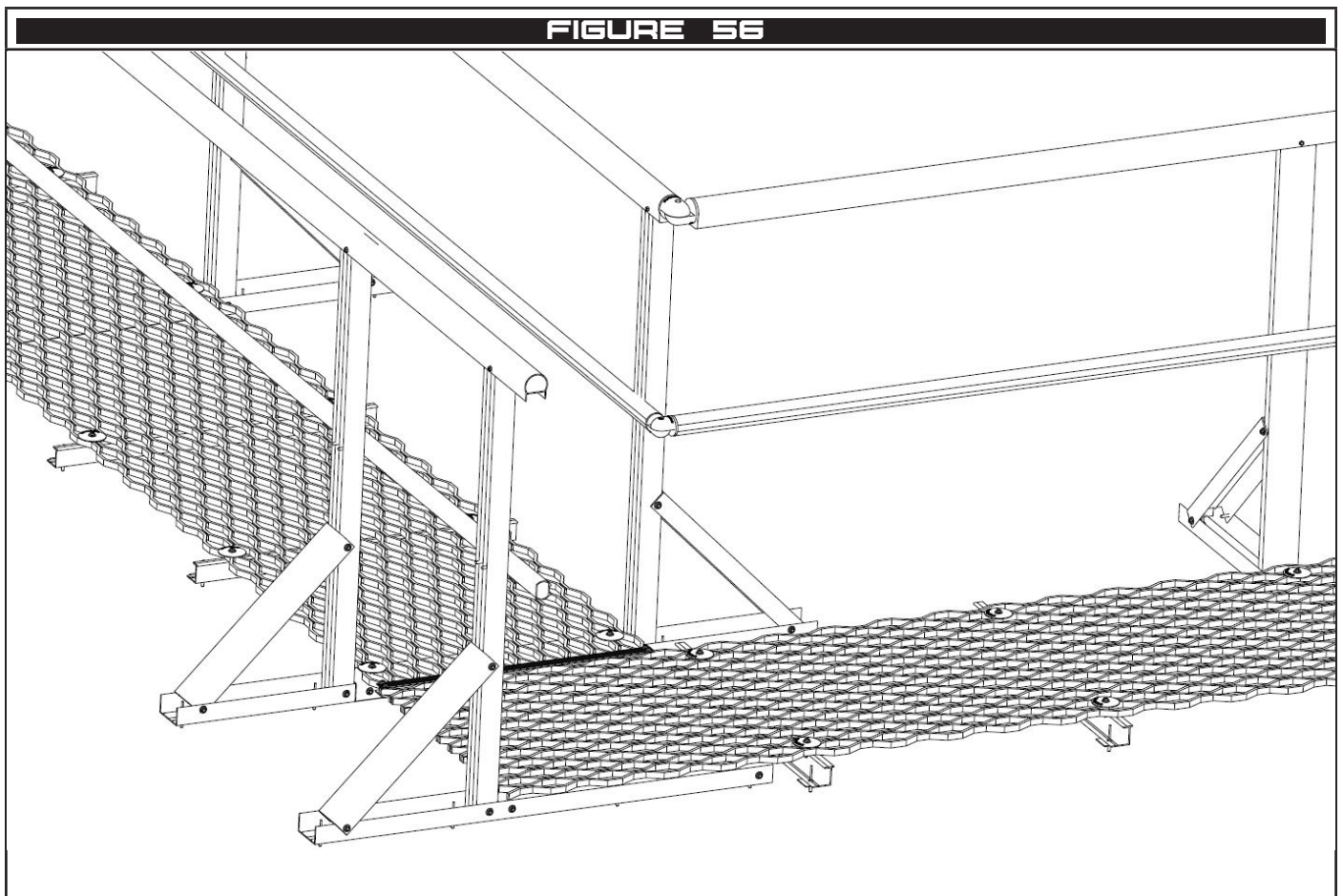

## 6.2 Kit 2

### 6.2.1 Single Guardrail Corner (Angled Roof)

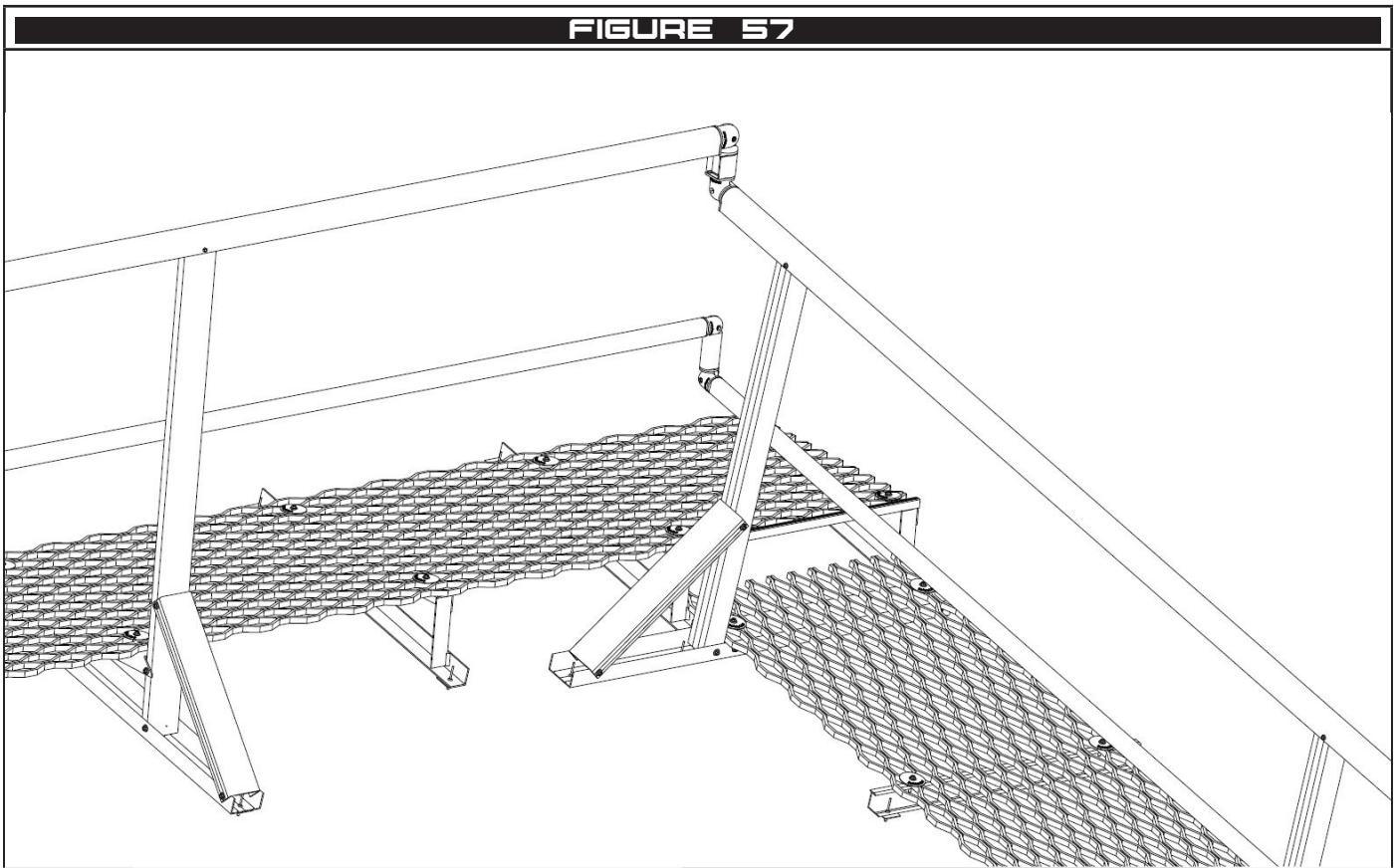

### 6.2.2 Double Guardrail Corner (Flat Roof)

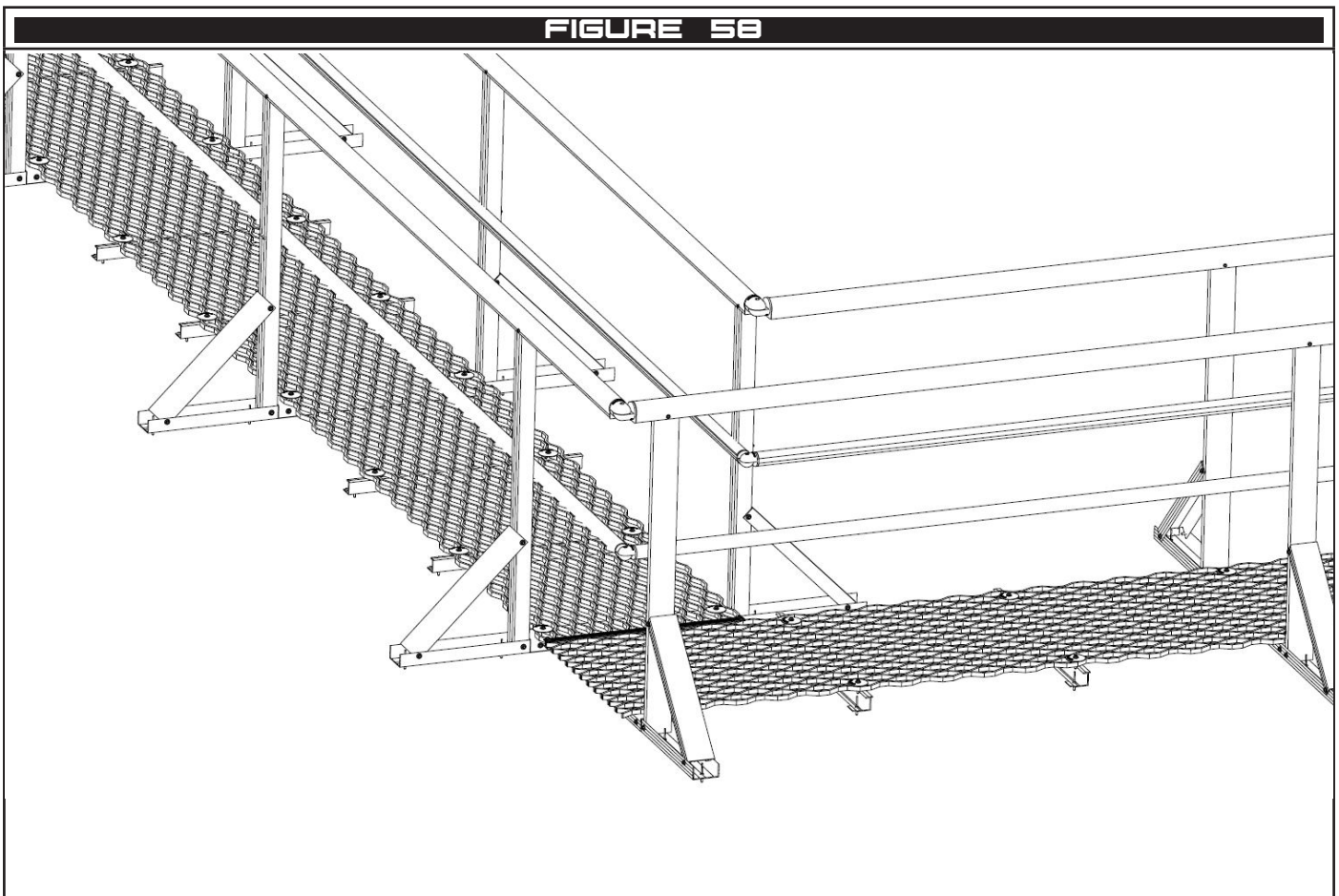

6.2.3 Double Guardrail T-Intersection (Flat Roof)

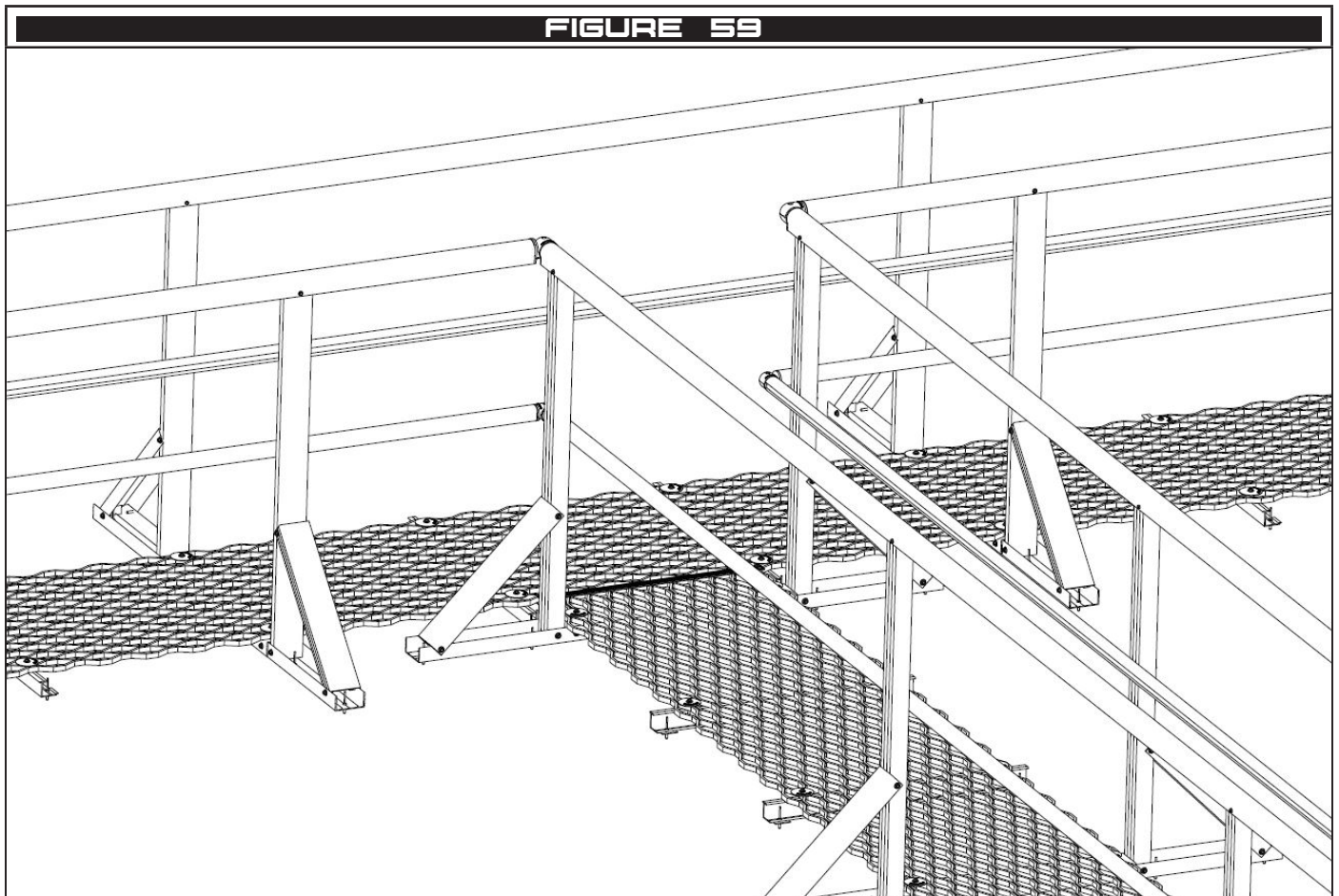

6.2.4 Double Guardrail to Single Guardrail T-Intersection (Flat Roof)

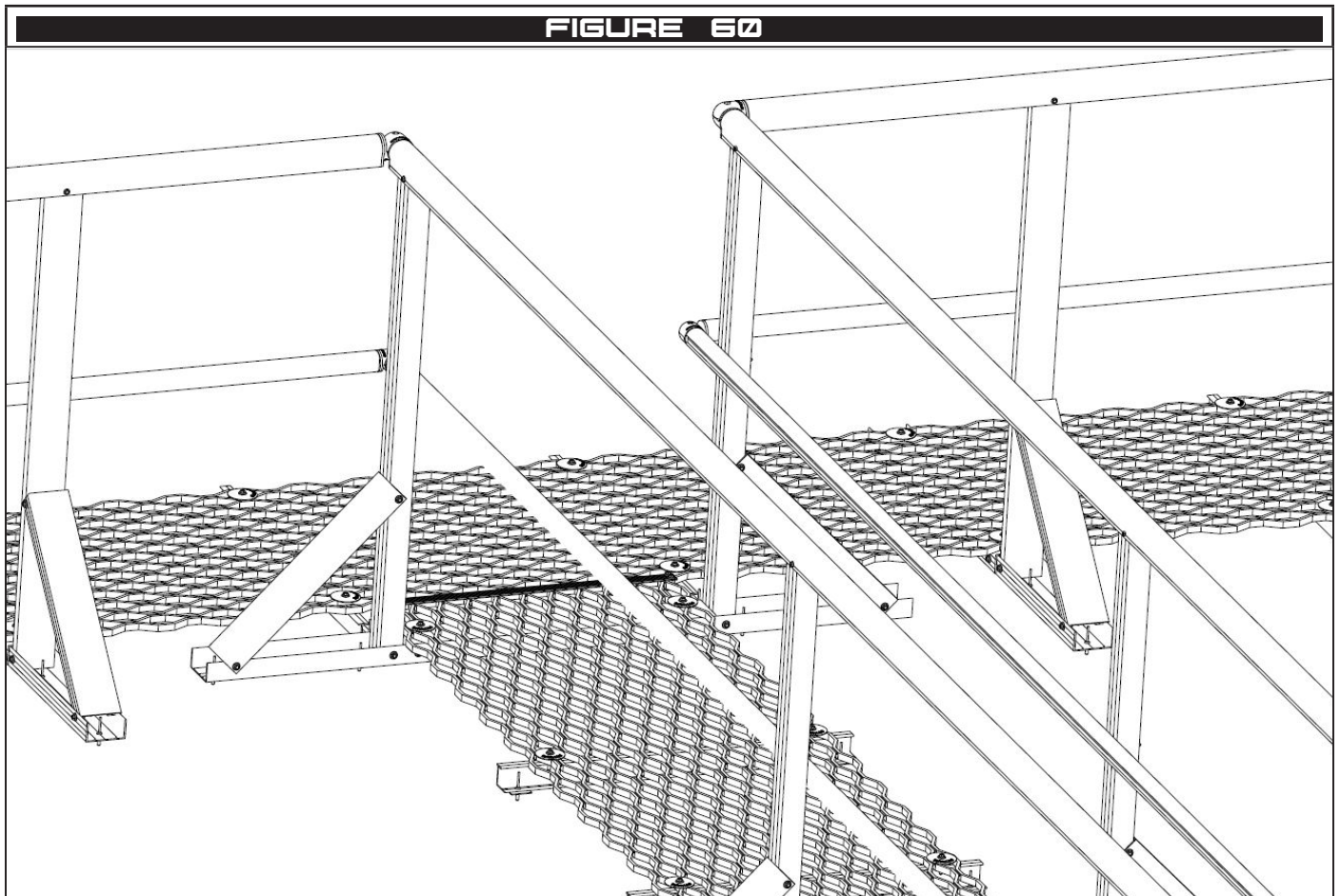

### 6.3 Kit 3

#### 6.3.1 Double Guardrail Corner (Angled Roof)

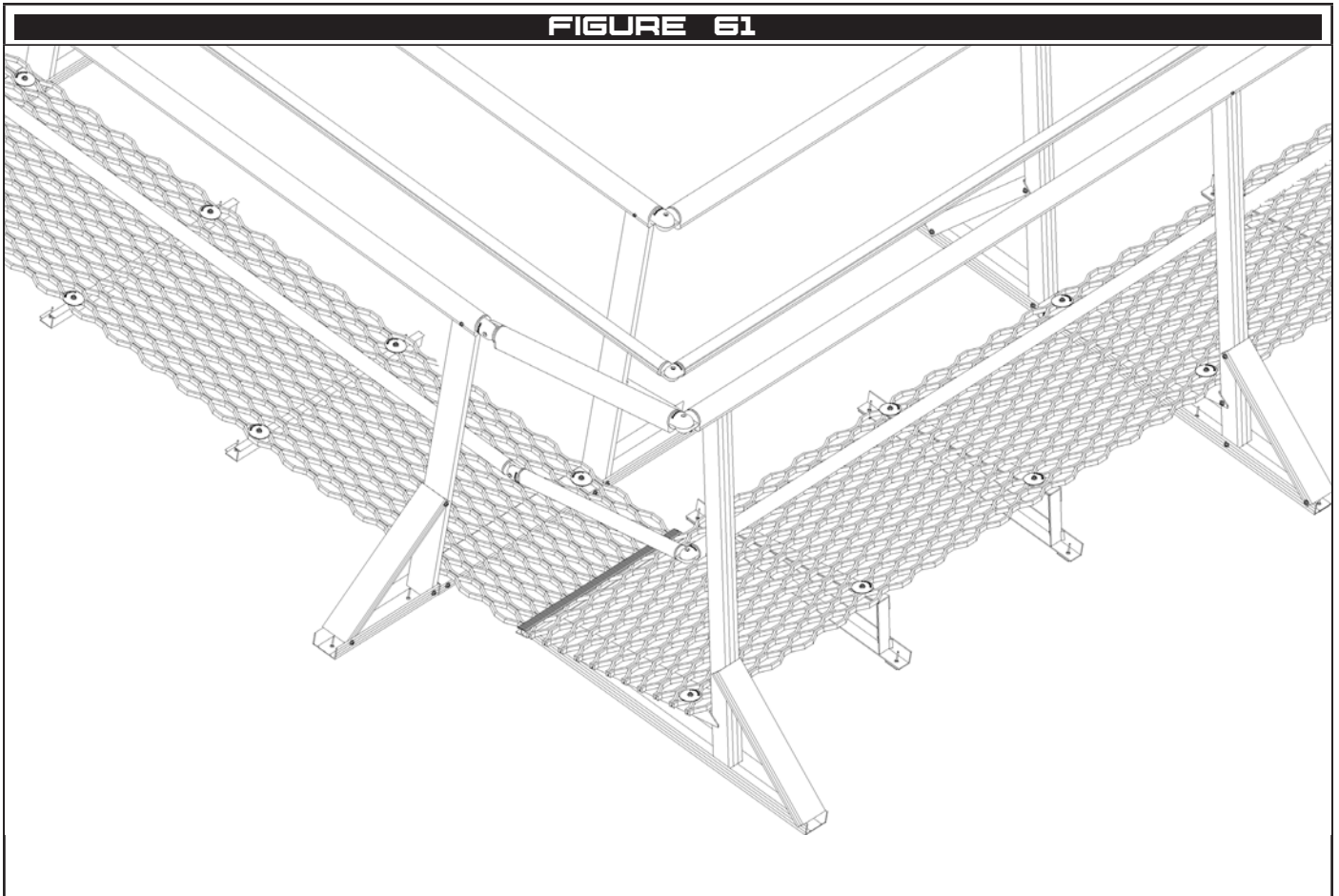

## 6.4 Kit 4

### 6.4.1 Double Guardrail T-Intersection (Angled Roof)

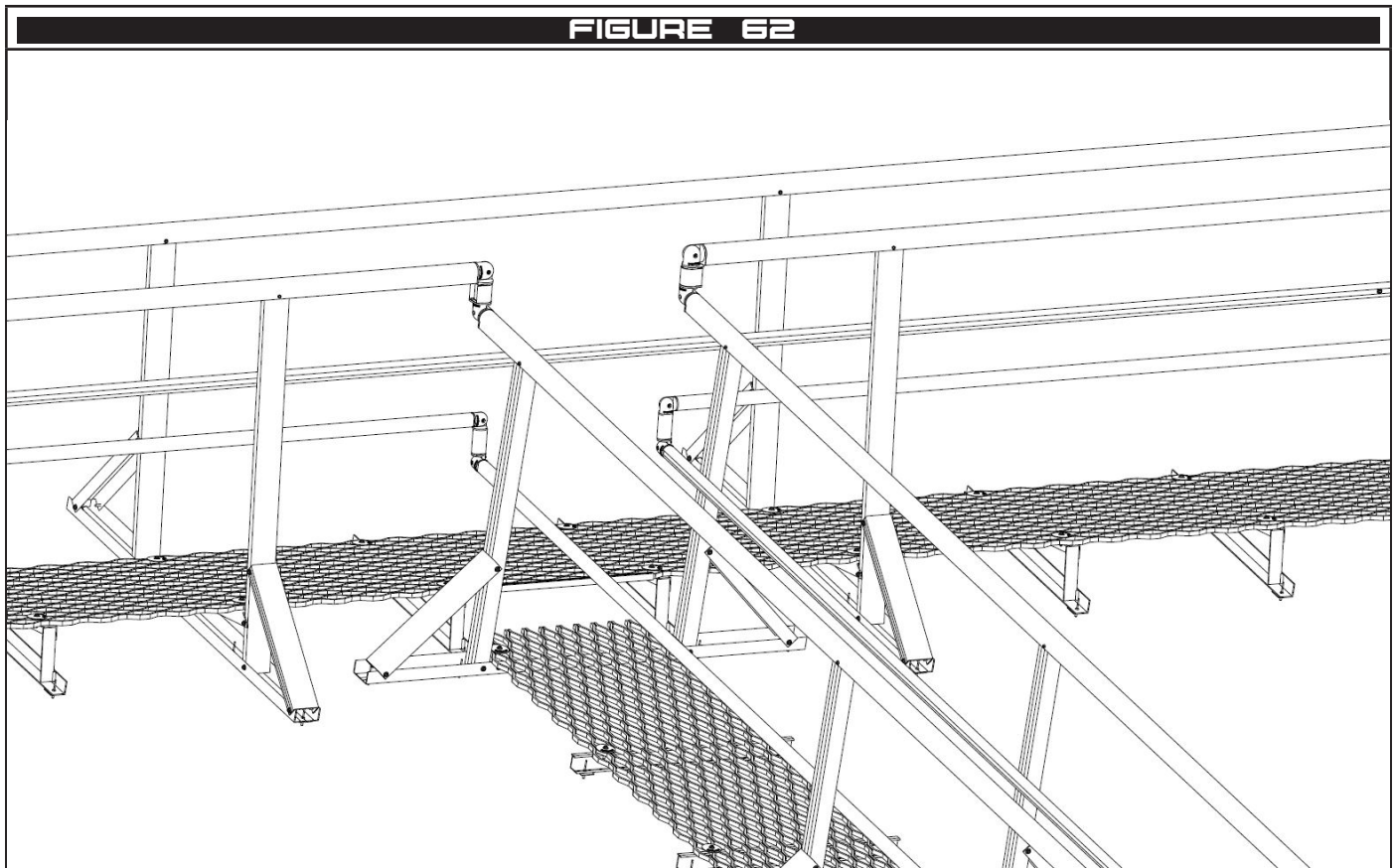

### 6.4.2 Double Guardrail to Single Guardrail T-Intersection (Angled Roof)

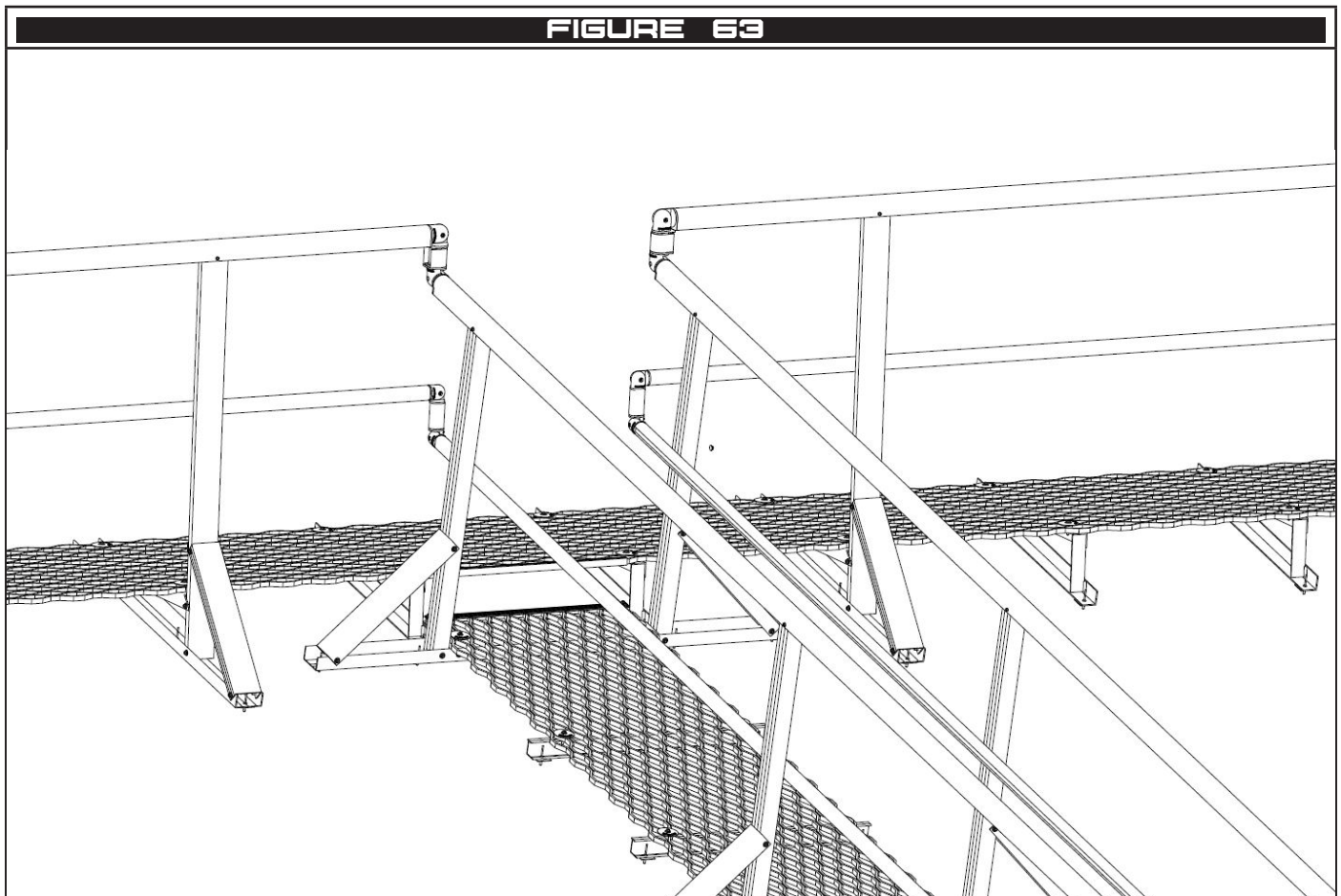

## 6.5 Kit 5

### 6.5.1 Double Guardrail to Single Guardrail Corner (Angled Roof)

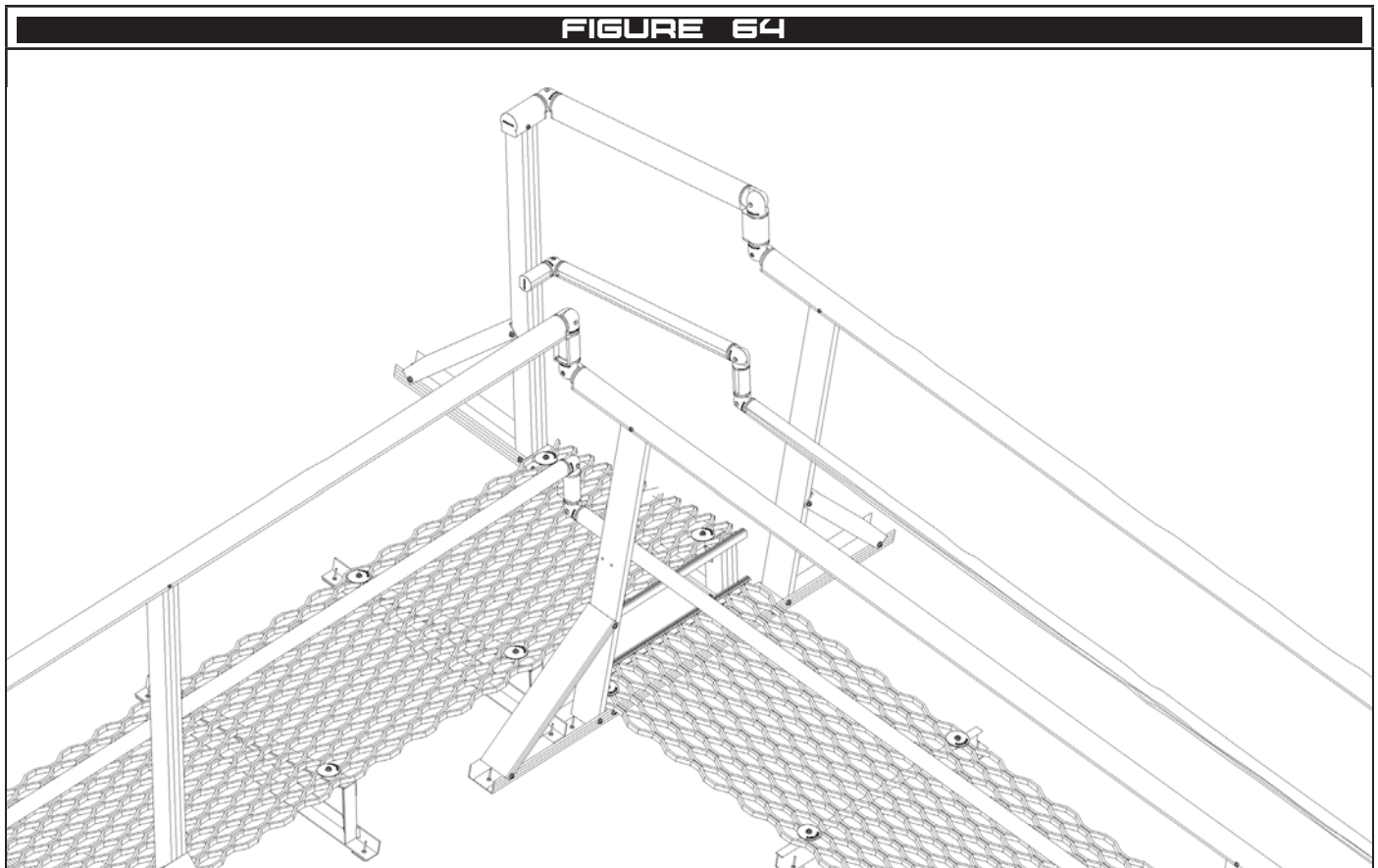

### 6.5.2 Double Guardrail Corner (Angled Roof)

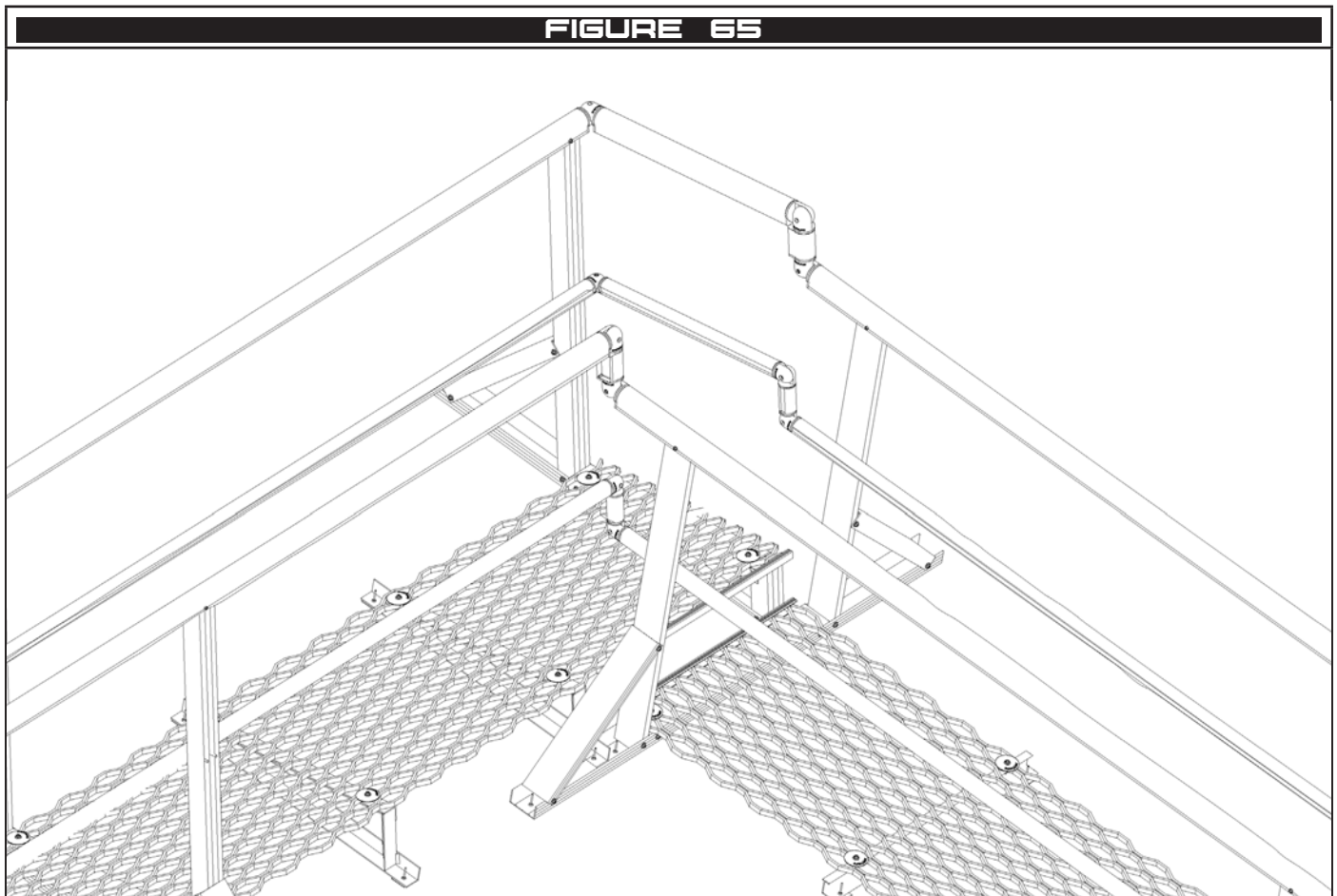

## 7 Skylight Bridging

### 7.1 Walkway Across Skylight with Angle

FIGURE 66

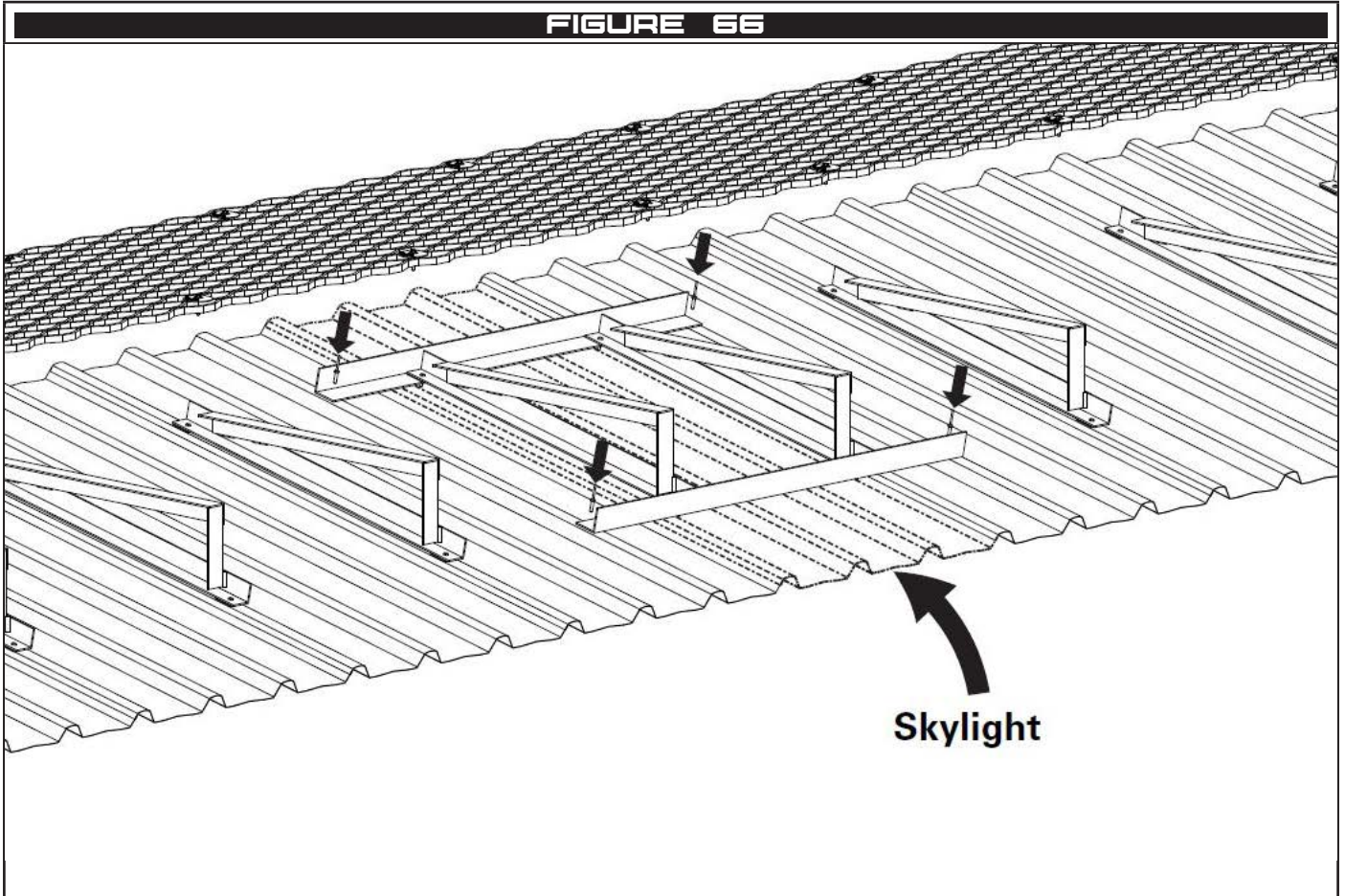

Skylight

Each angle support shall be fixed with 2x 5mm trifold rivets. The rivets shall be installed in to the first crest beyond the skylight. Ensure that the foam tape is used to prevent compromising the structures waterproofing.

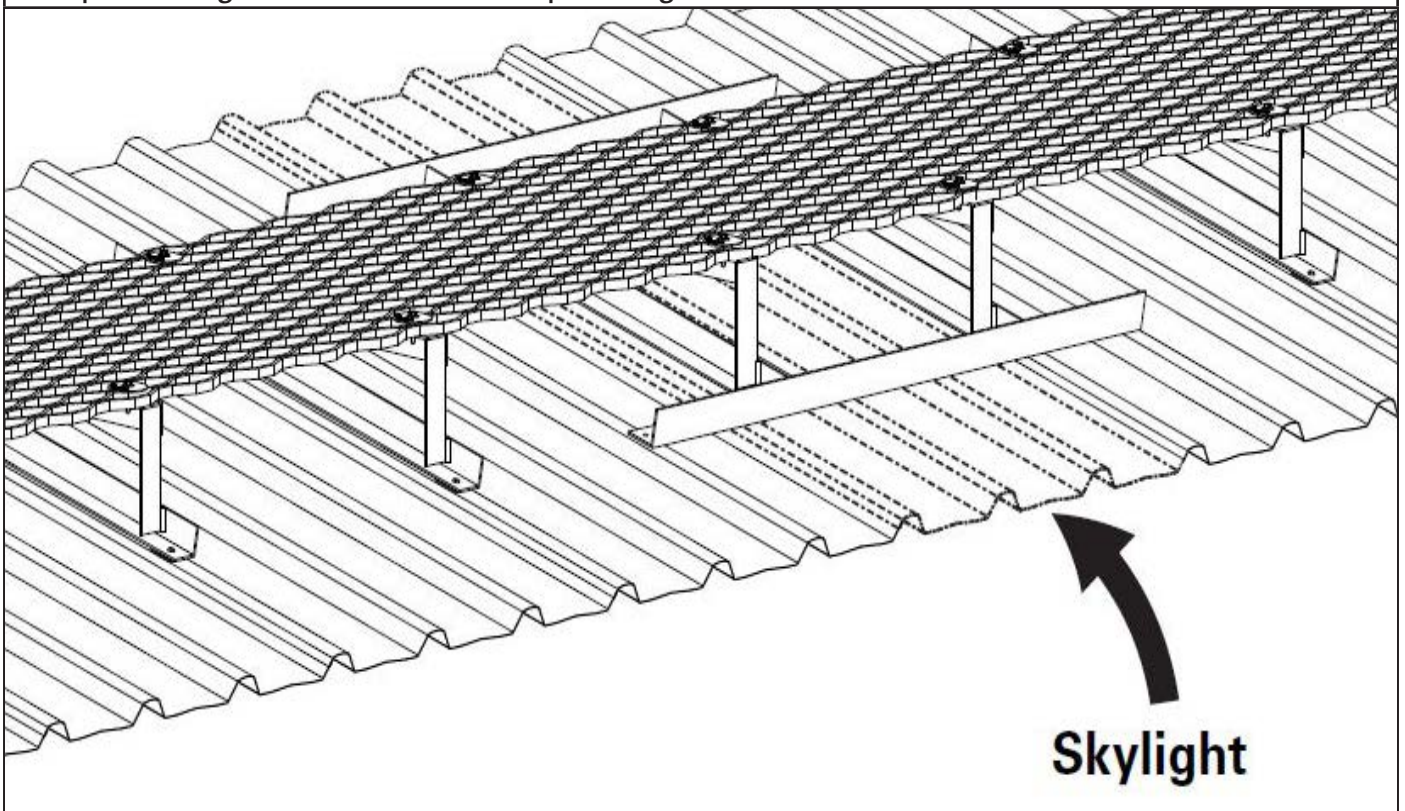

Skylight

Stanchion shall not be installed on support angles.

## 7.2 Walkway Across Skylight with Walkway Battens

FIGURE 67

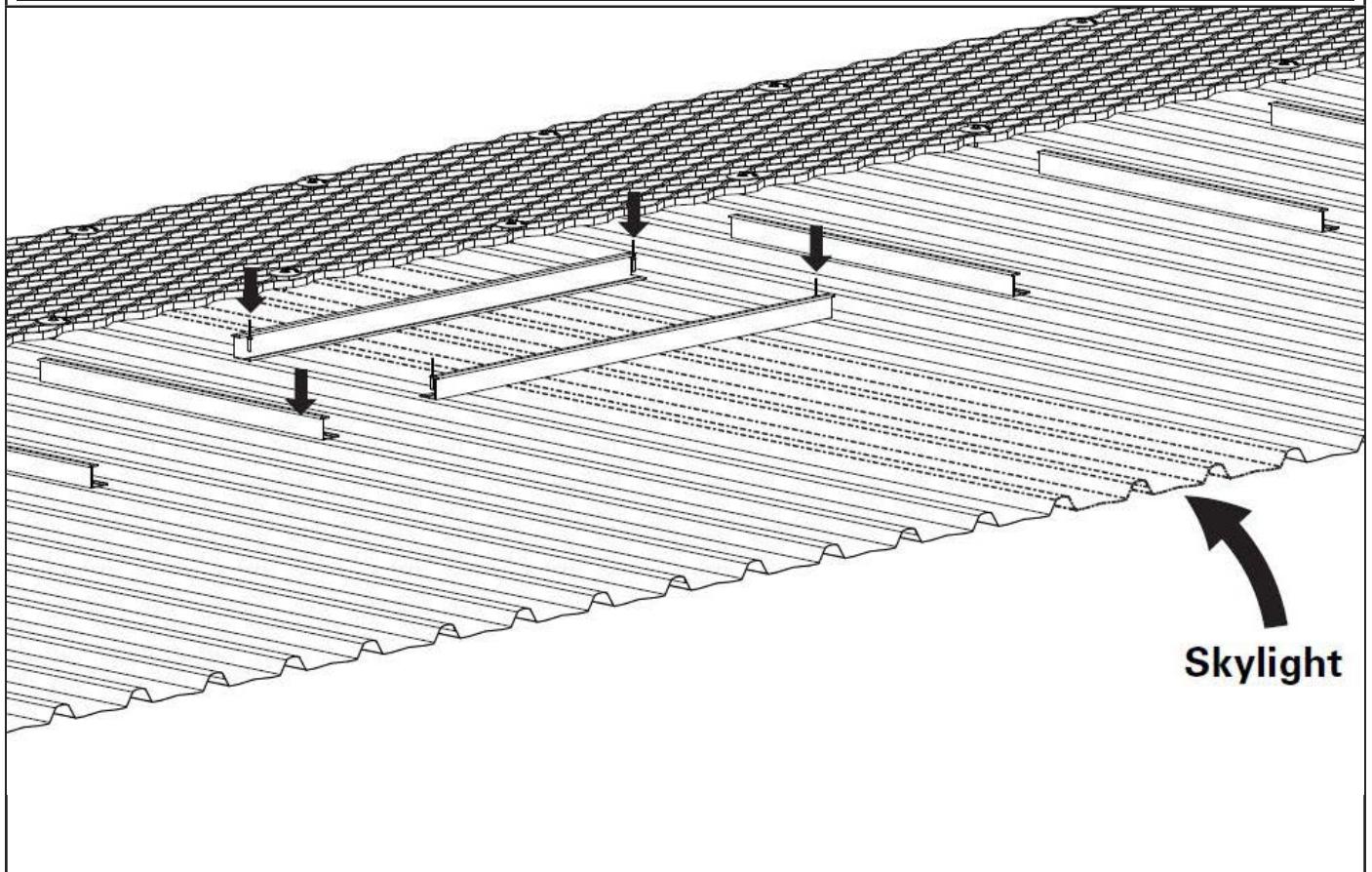

Each batten support shall be fixed with 2x 5mm trifold rivets. The rivets shall be installed in to the first crest beyond the skylight. Ensure that the foam tape is used to prevent compromising the structures waterproofing.

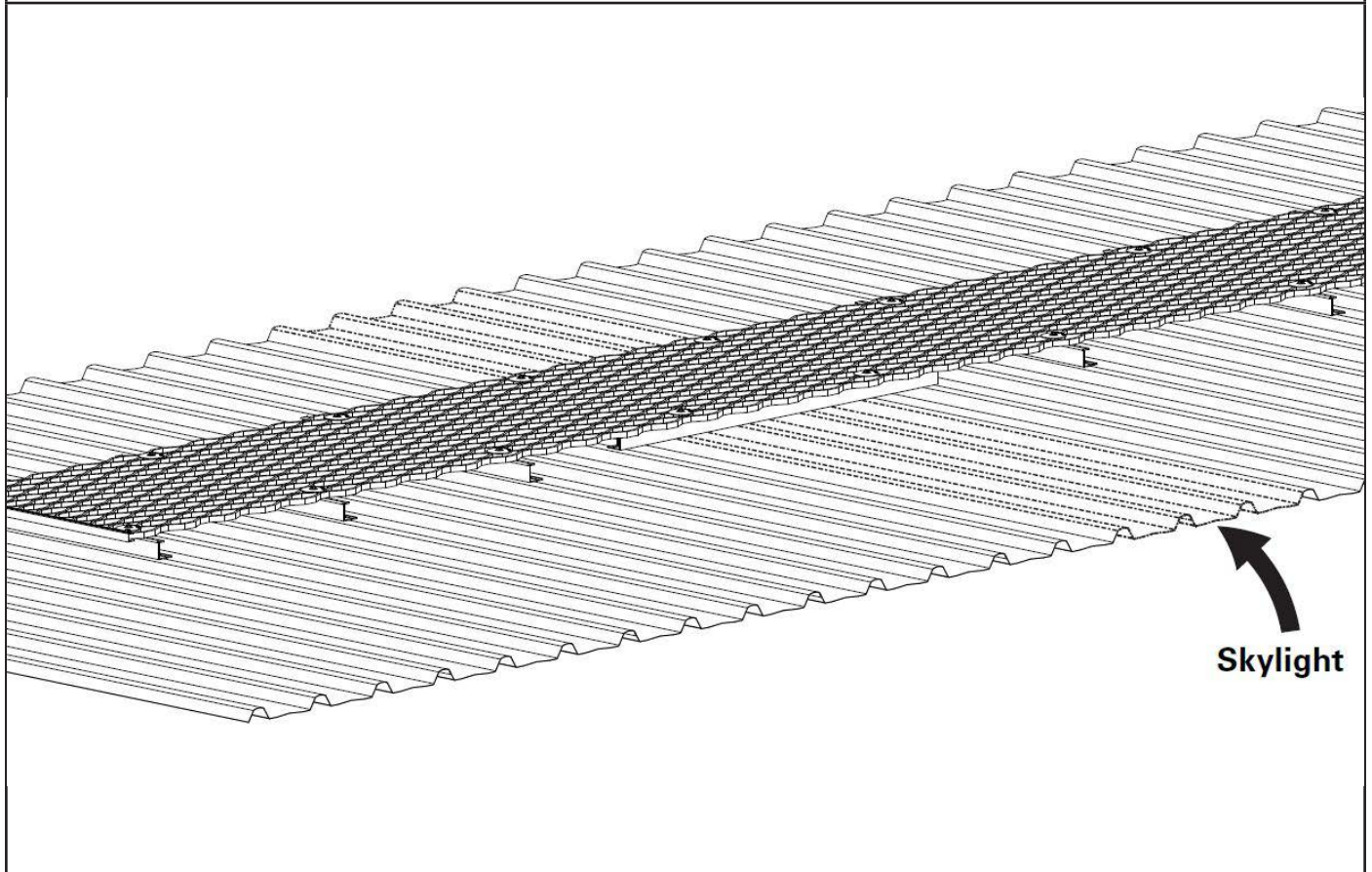

Stanchion shall not be installed on support battens.

### 7.3 Walkway Along Skylight with Channel Supports

FIGURE 68

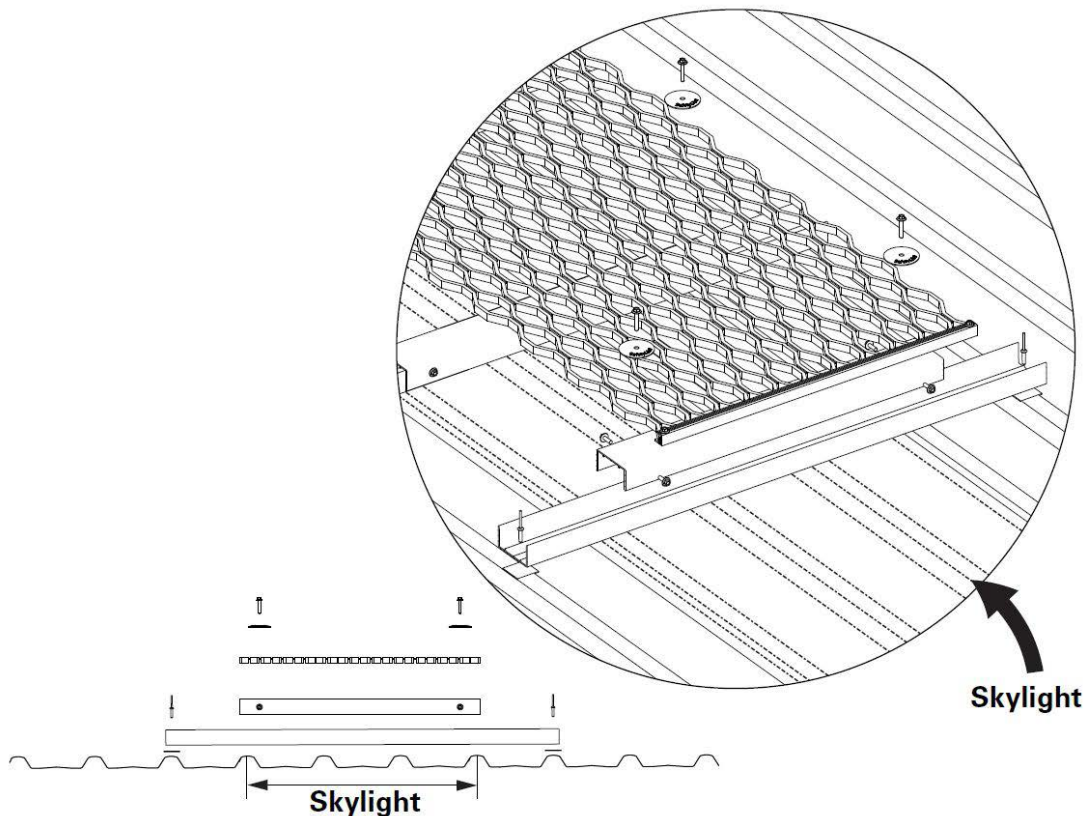

Each channel support shall be fixed with 2x 5mm trifold rivets. The rivets shall be installed in to the first crest beyond the skylight. Ensure that the foam tape is used to prevent compromising the structures waterproofing. Each support channel shall be capped with a mesh support channel fixed with 4x 20mm tek screws (GUARD\_WALK.HDU.S).

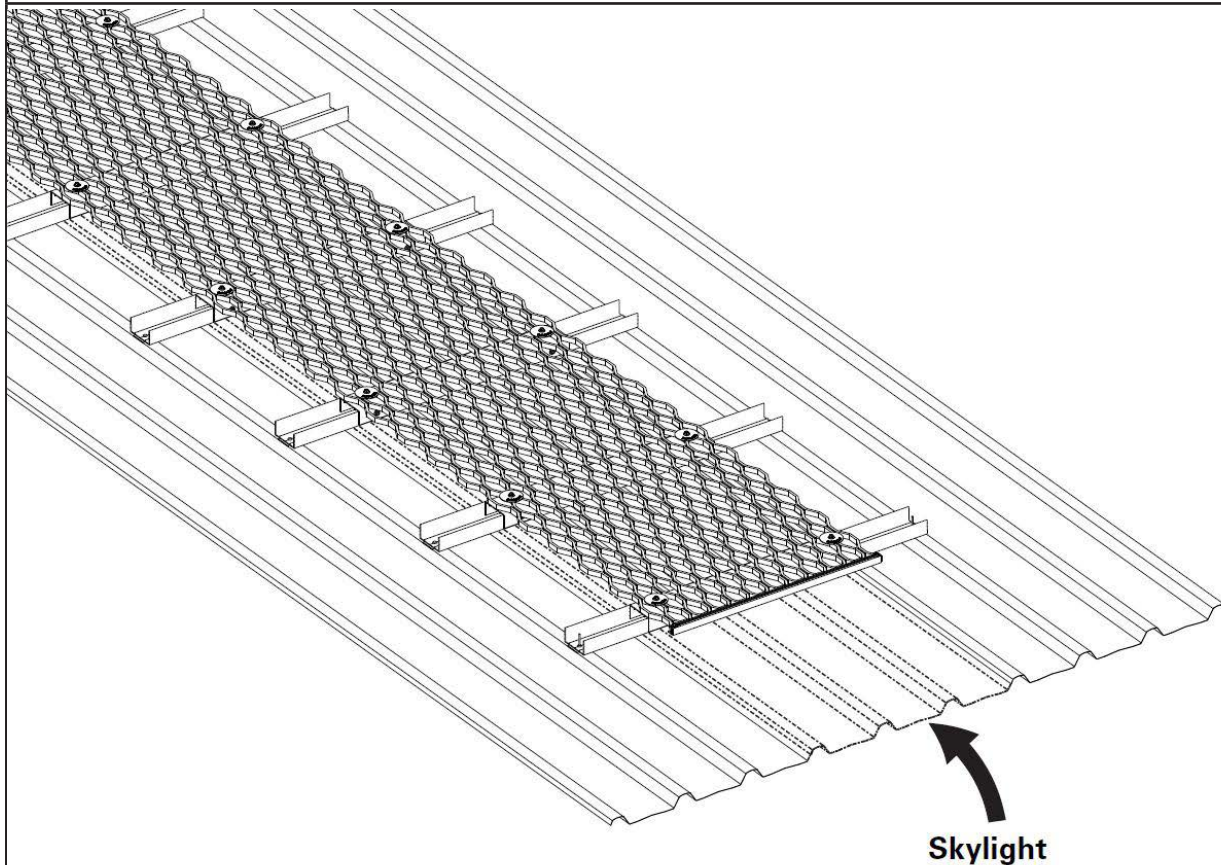

## 7.4 Walkway Along Skylight with RHS Supports

FIGURE 69

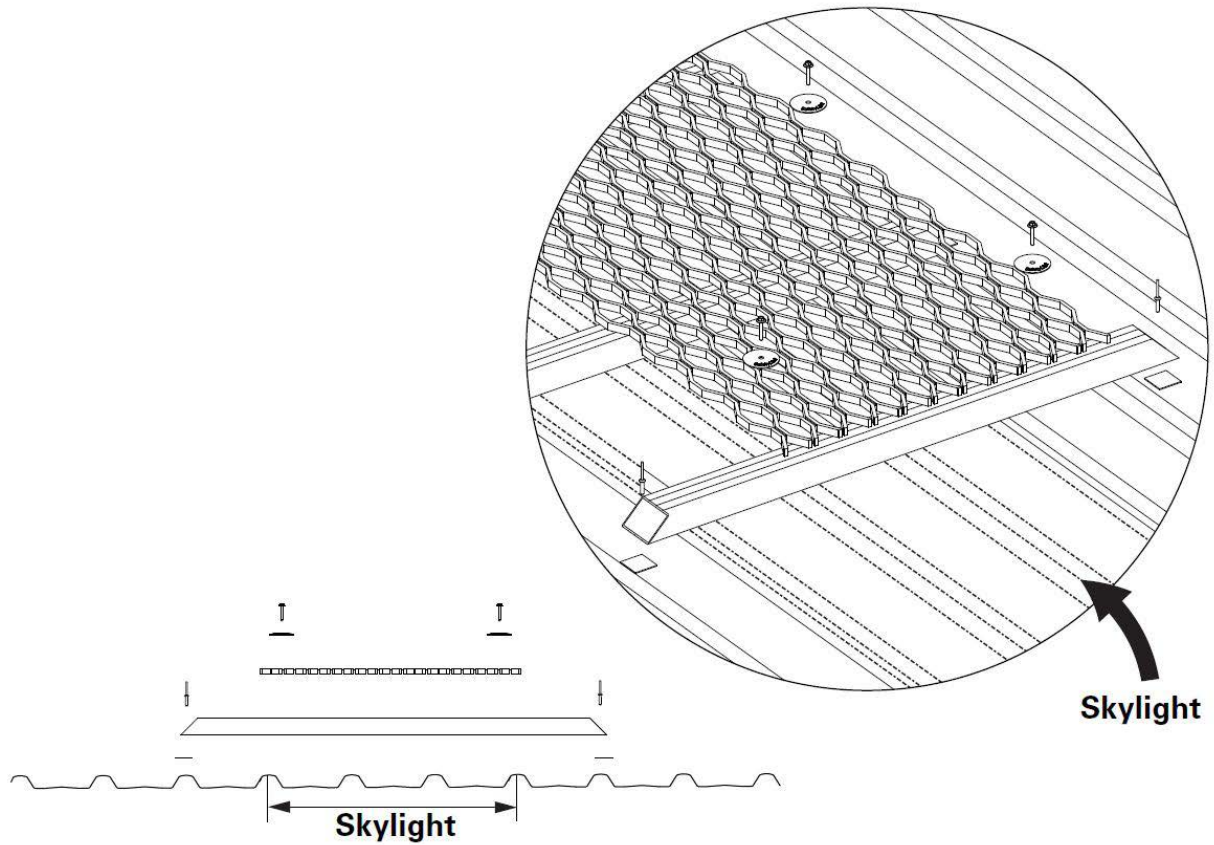

Each RHS support shall be fixed with 2x 5mm trifold rivets. The rivets shall be installed in to the first crest beyond the skylight. Ensure that the foam tape is used to prevent compromising the structures waterproofing (GUARD\_WALK.HD.S).

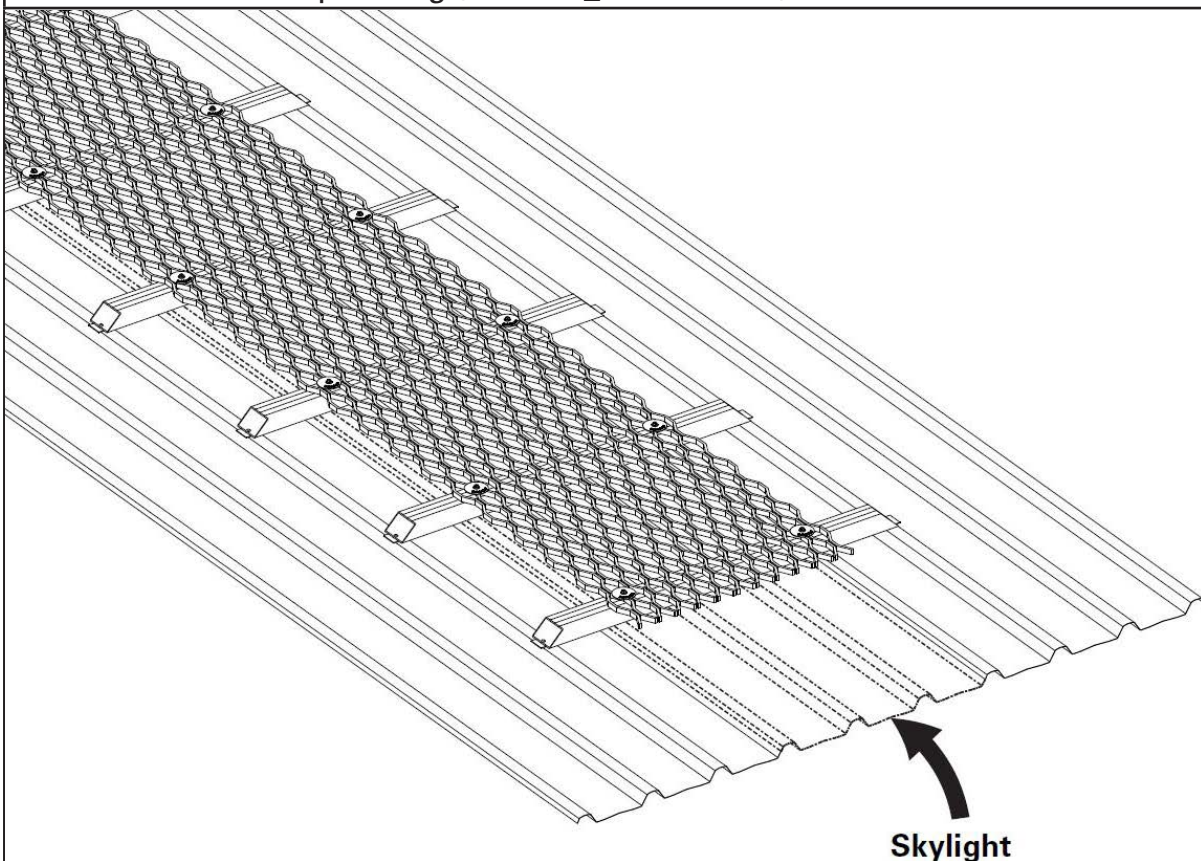

## 8 Skylight Protection

### 8.1 Flat

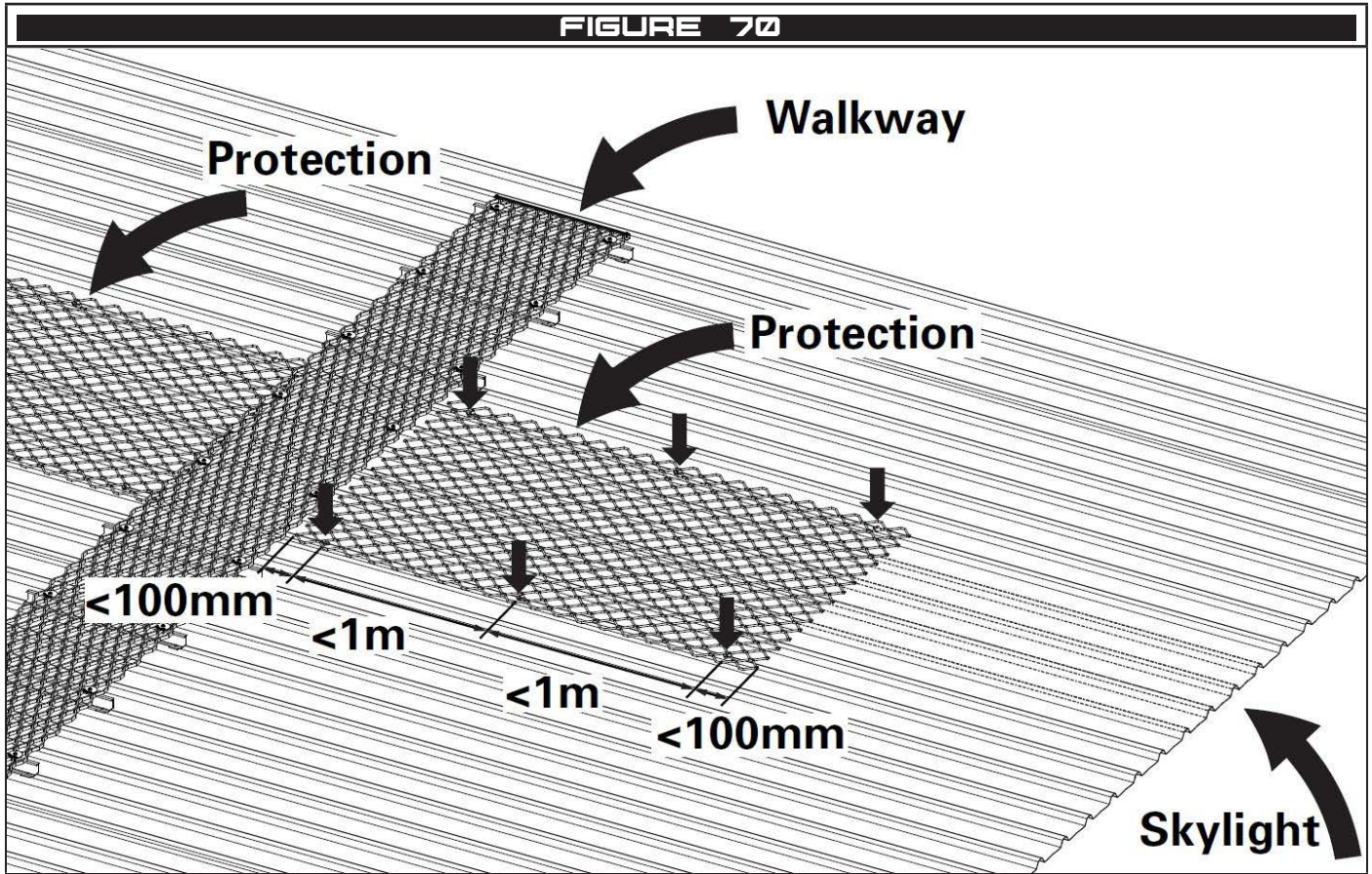

The spacing between fixings to the roof sheet shall not exceed 1m down each edge of the mesh. There shall also be a fixing on either edge not more than 100mm from the end of mesh.

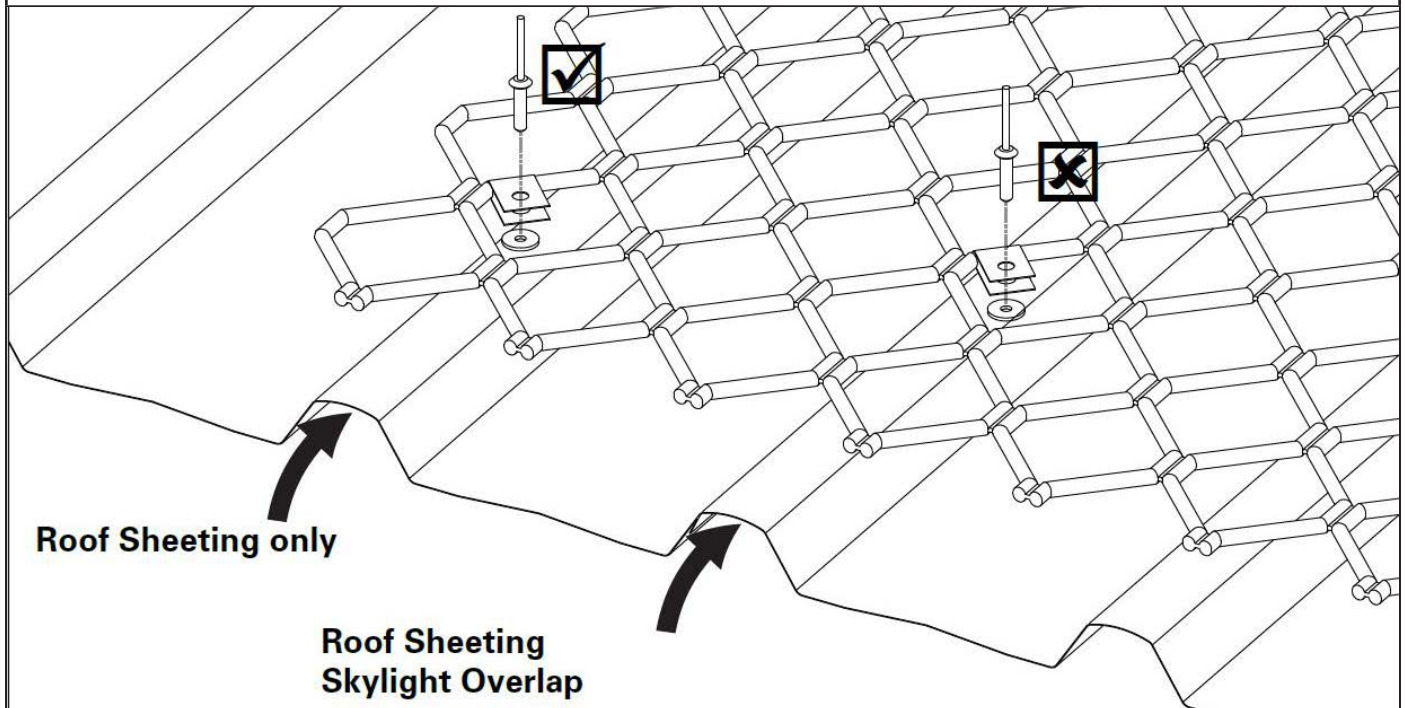

The protection shall be fixed to the roof sheeting with a 5mm trifold rivet and U-clip. Ensure the rubber washer is placed below the U-clip to prevent compromising the structures waterproofing. The rivets shall be installed in to the first crest beyond the skylight, not in to the roof sheeting skylight overlap crest.

## 8.2 Raised

FIGURE 71

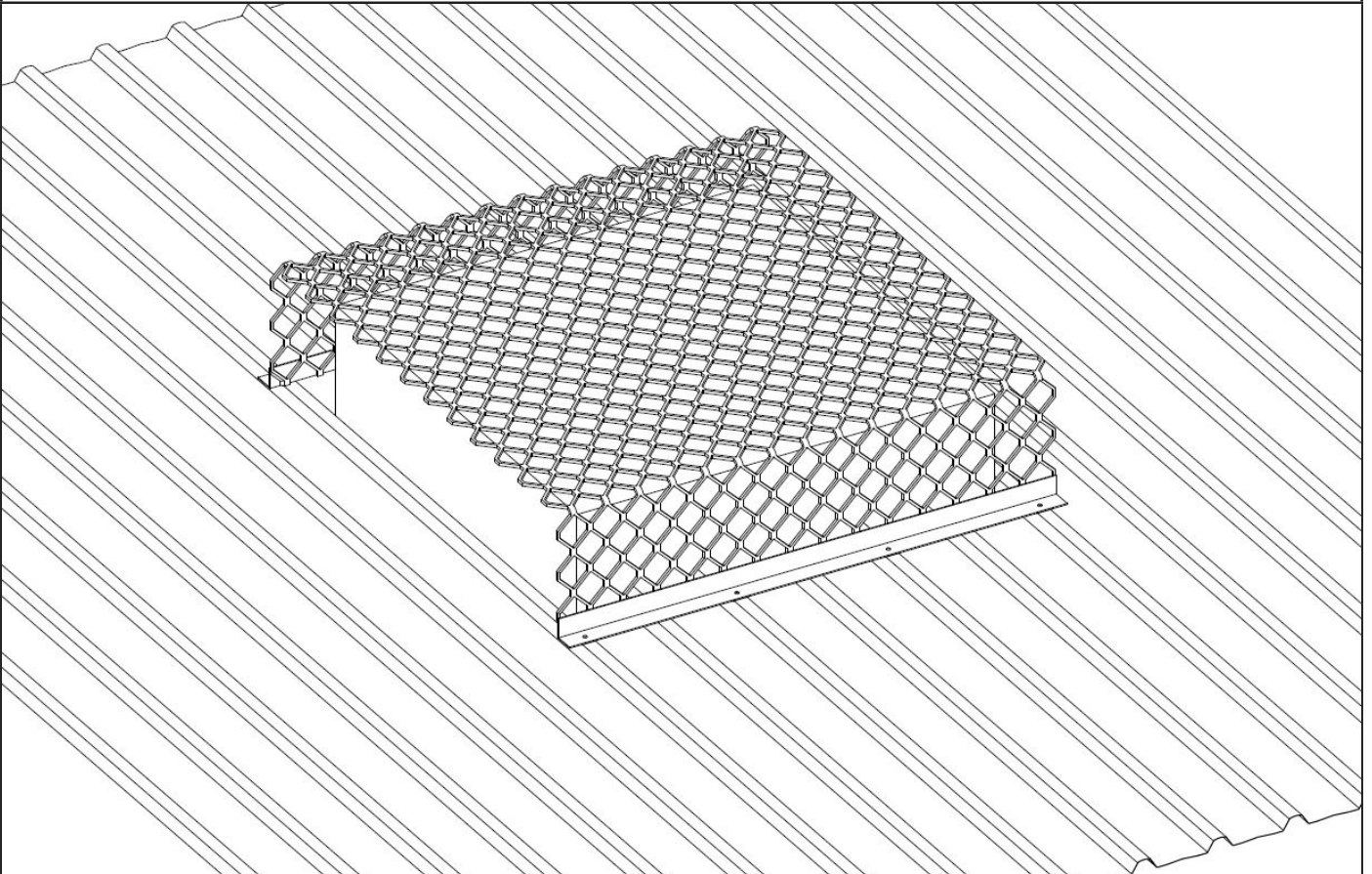

Position the protector over the skylight.

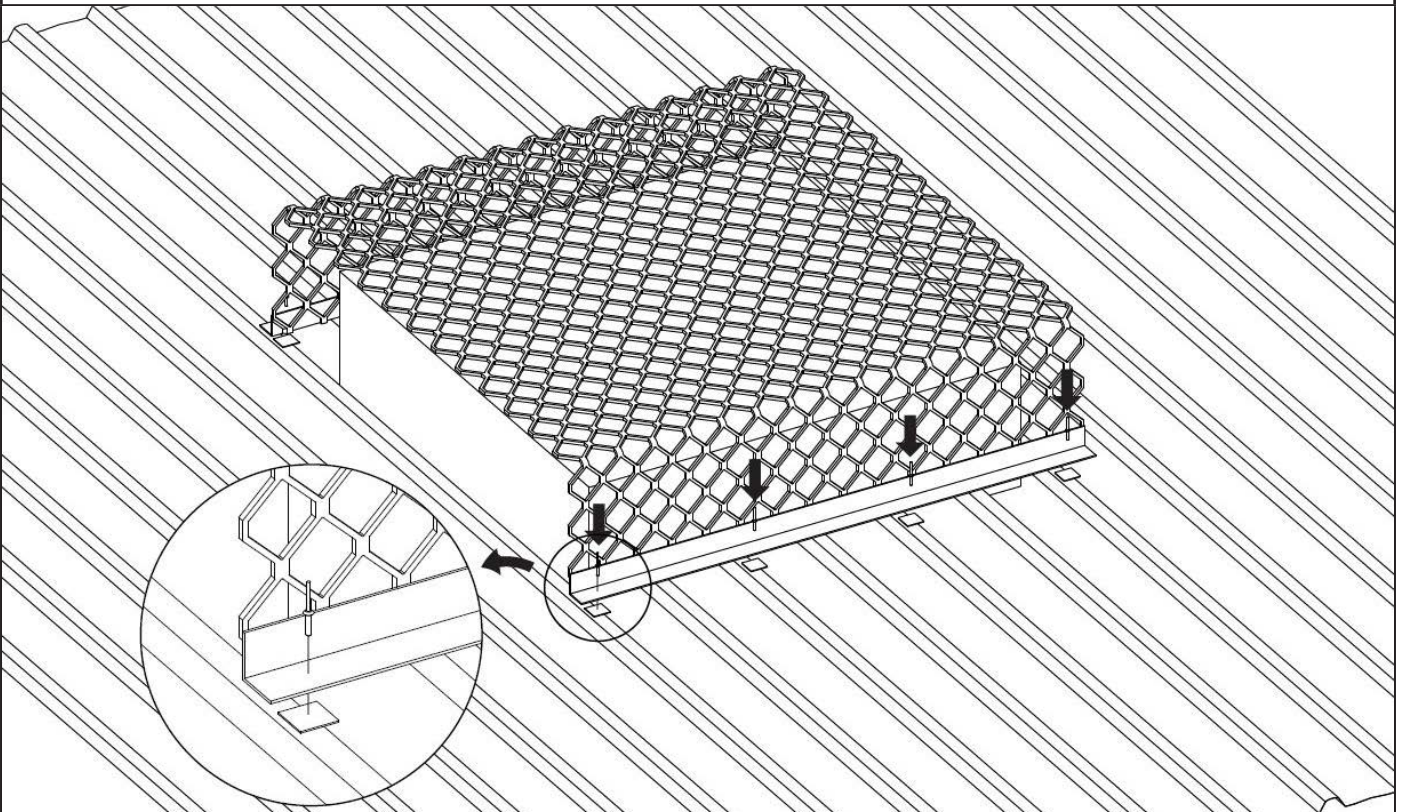

Each side of the protector shall be fixed with 4x 5mm trifold rivets. Ensure that the foam tape is used to prevent compromising the structures waterproofing.

### 8.3 Frame

FIGURE 72

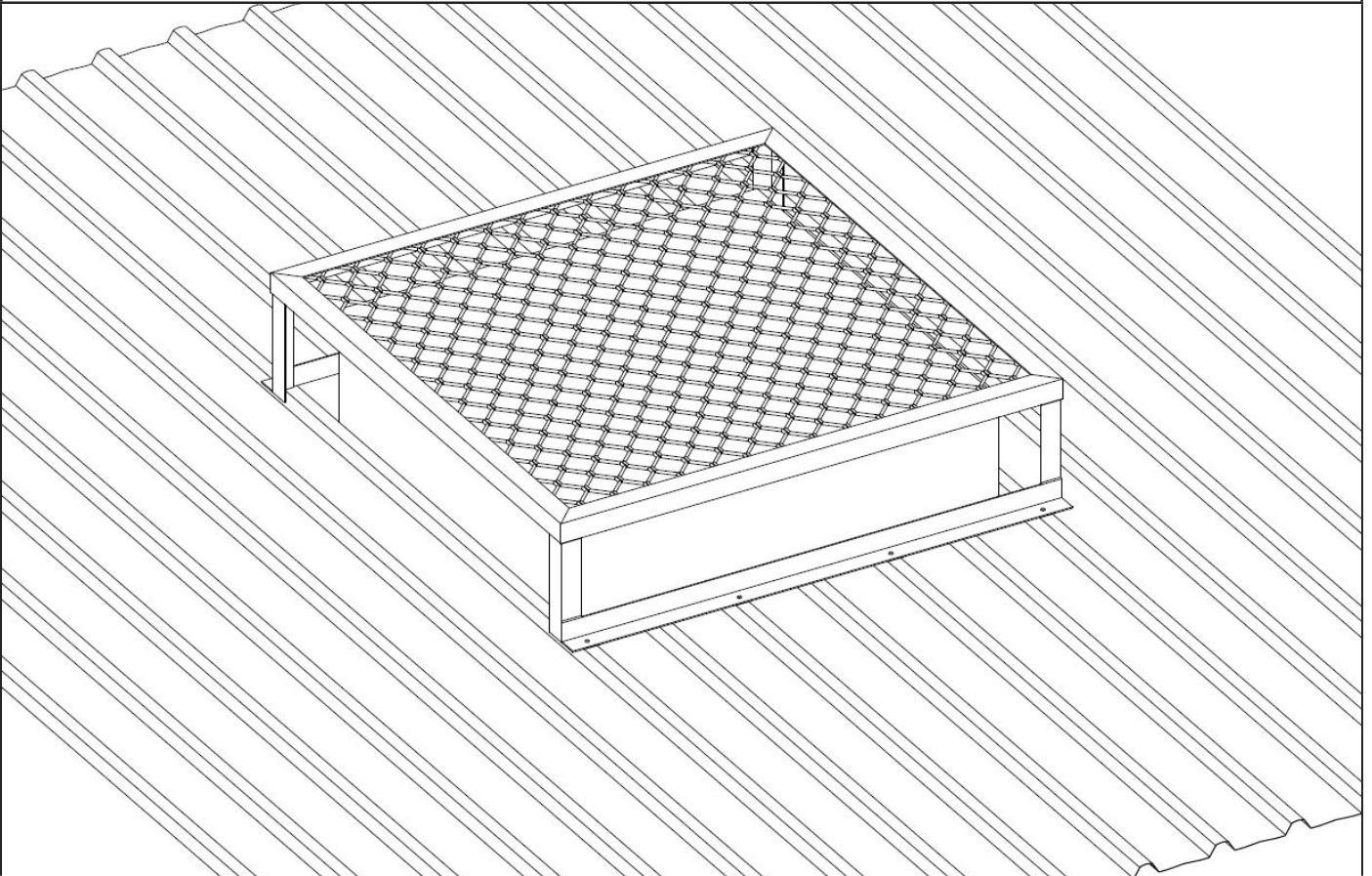

Position the protector over the skylight.

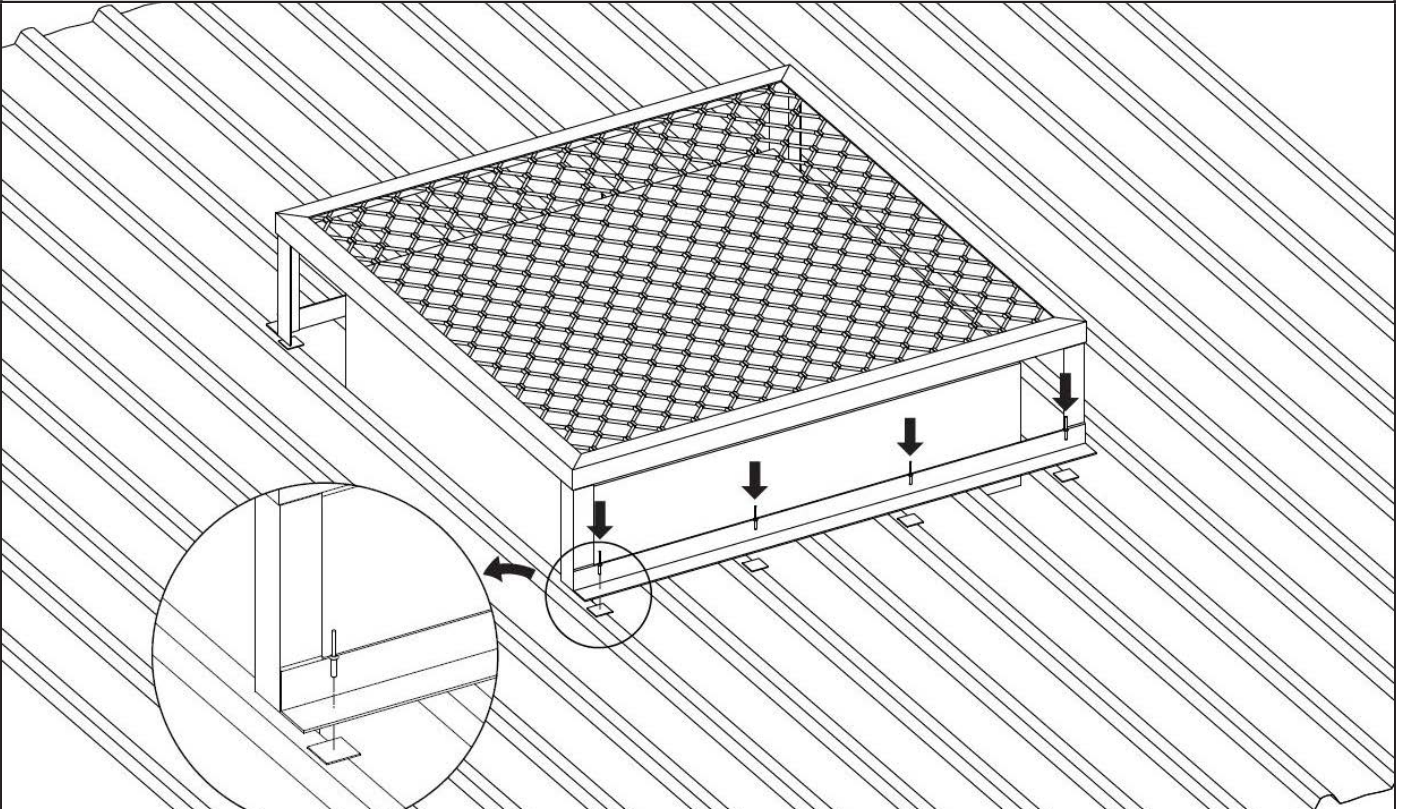

Each side of the protector shall be fixed with 4x 5mm trifold rivets. Ensure that the foam tape is used to prevent compromising the structures waterproofing.

## 9 Hatch Kits

### 9.1 Concrete

**FIGURE 73**

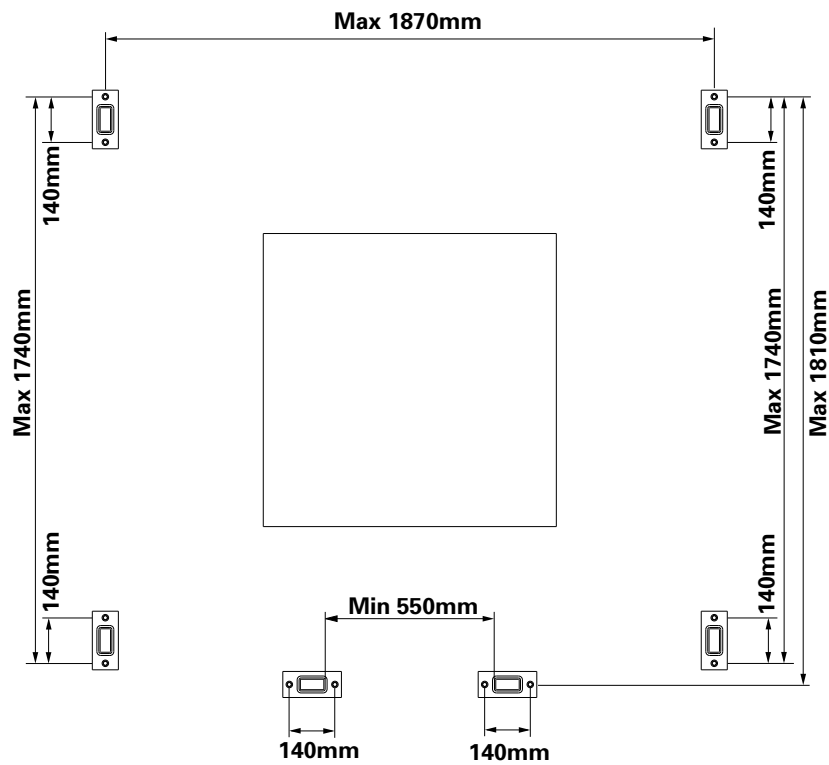

The above dimensions represent the maximum dimension of the supplied item. The hatch can be cut in either direction to suit different installations.

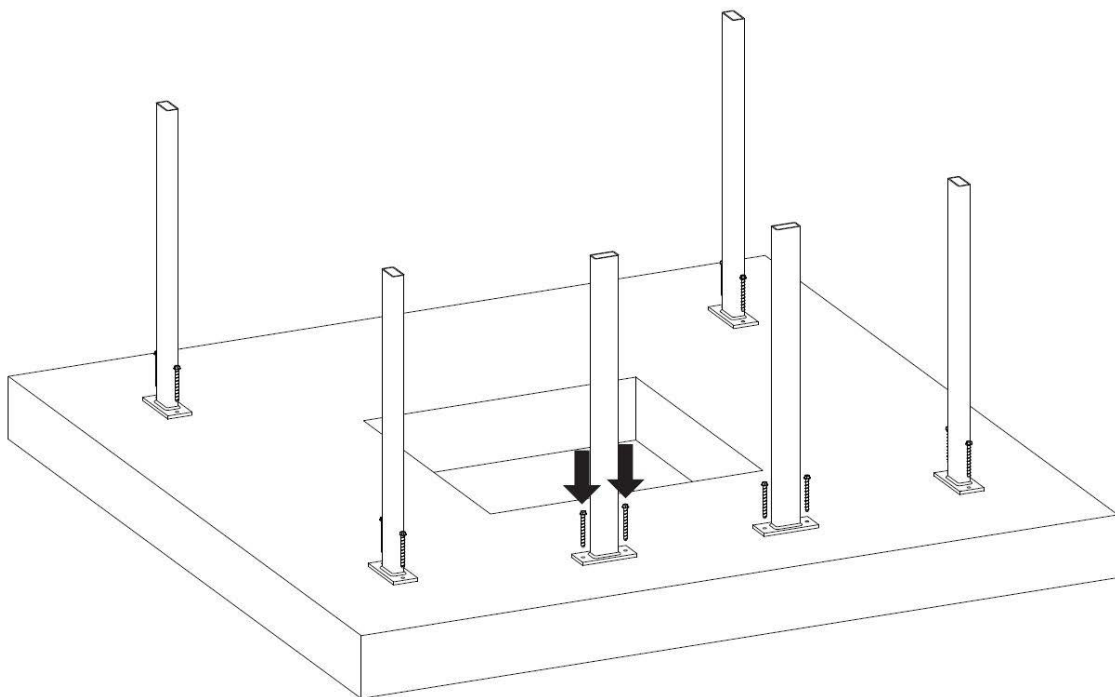

Each stanchion shall be fixed with 2x fasteners from sections 3.3.6 or 3.3.7.

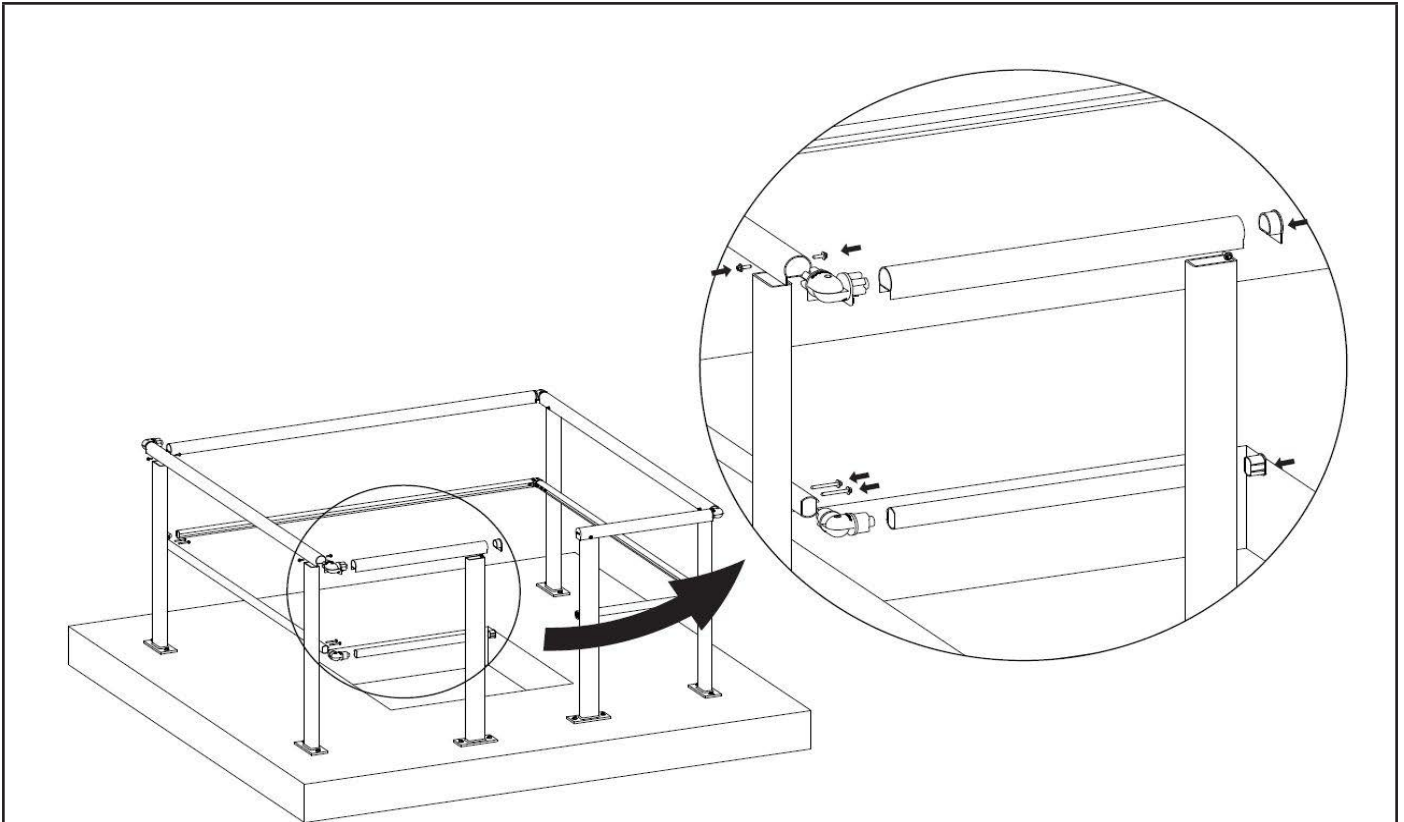

Fix the handrail, middle rail and corners. Install the rail end caps.

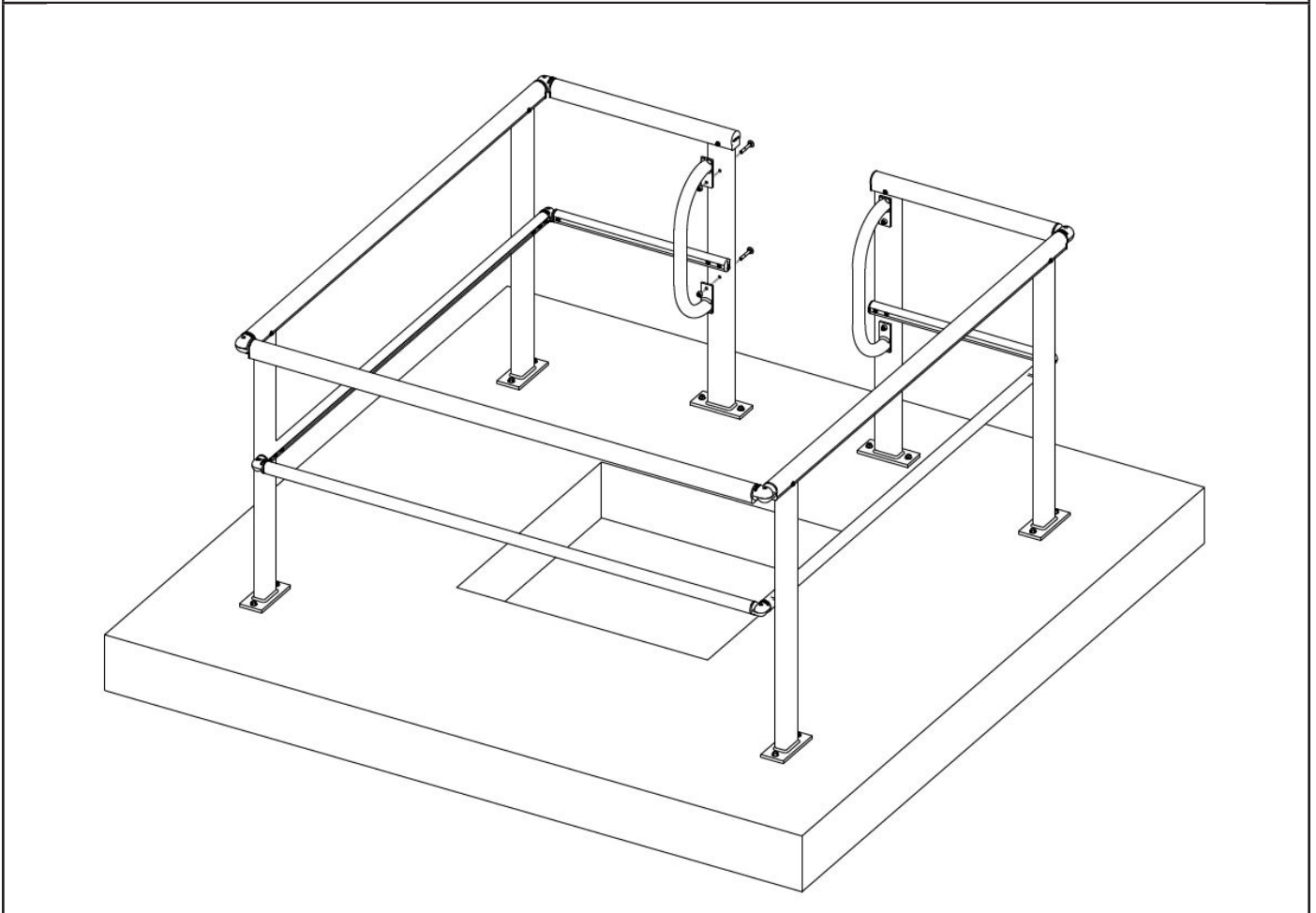

Fix each grab rail with 2x M8x60mm cup head bolt.

## 9.2 Roof Sheeting

**FIGURE 74**

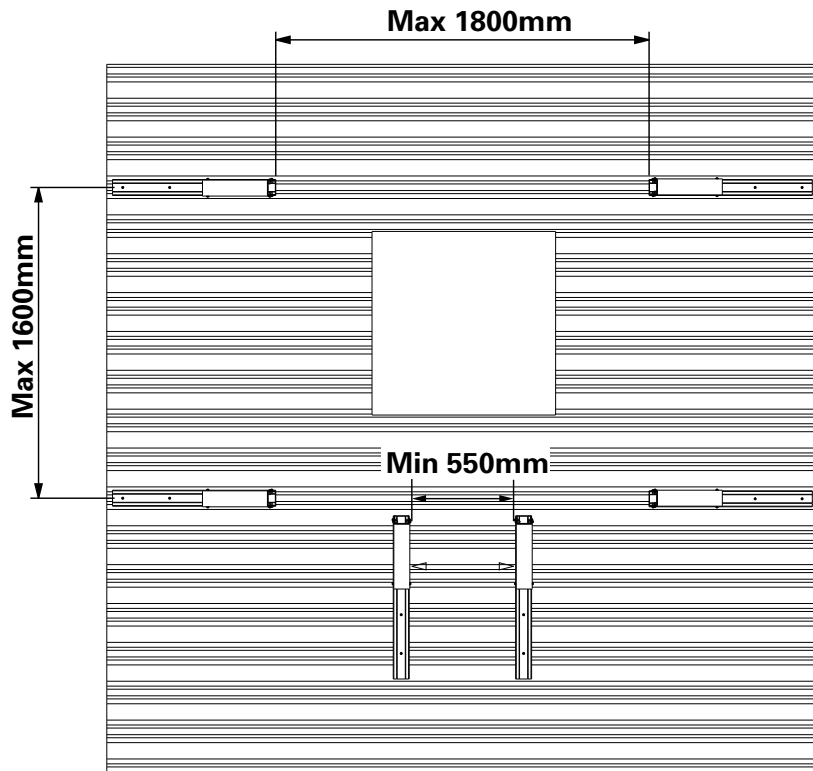

The above dimensions represent the maximum dimension of the supplied item. The hatch can be cut in either direction to suit different installations.

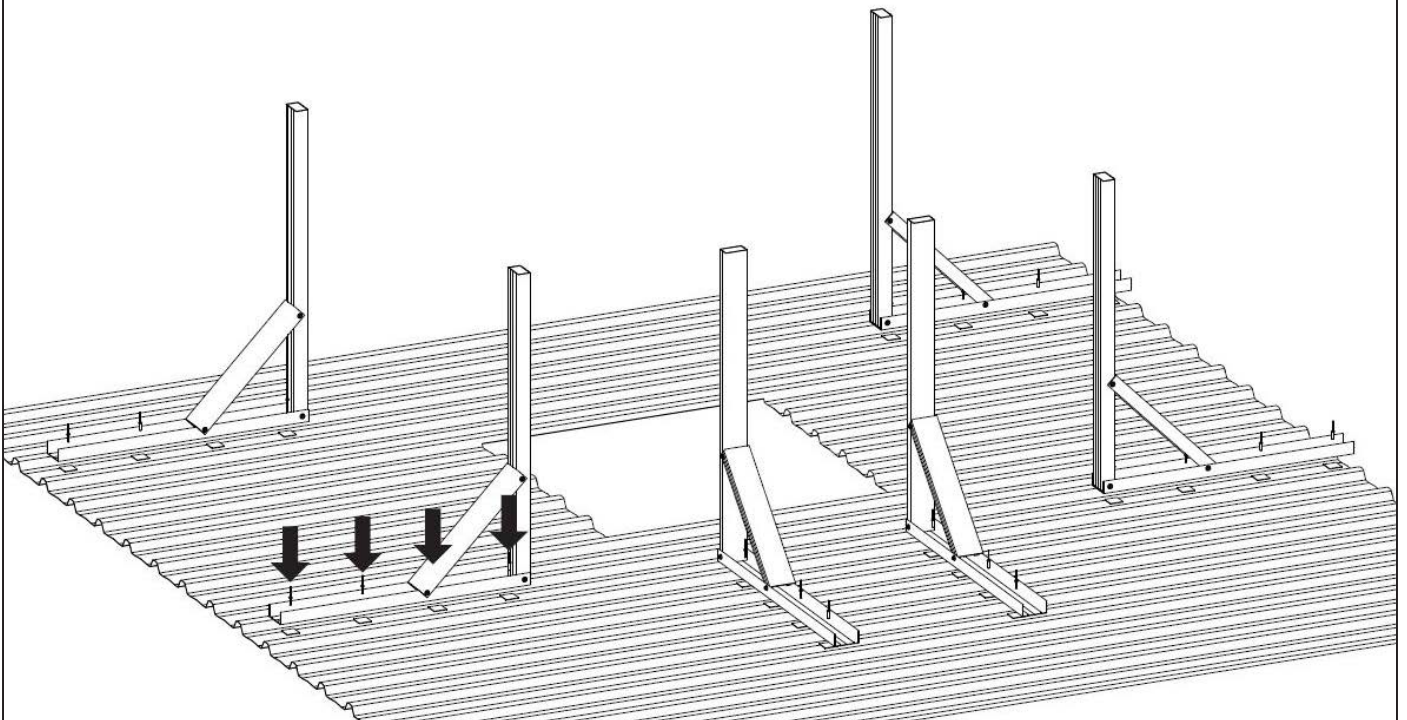

Each stanchion shall be fixed with 4x 5mm trifold rivet. Ensure that the foam tape is used to prevent compromising the structures waterproofing.

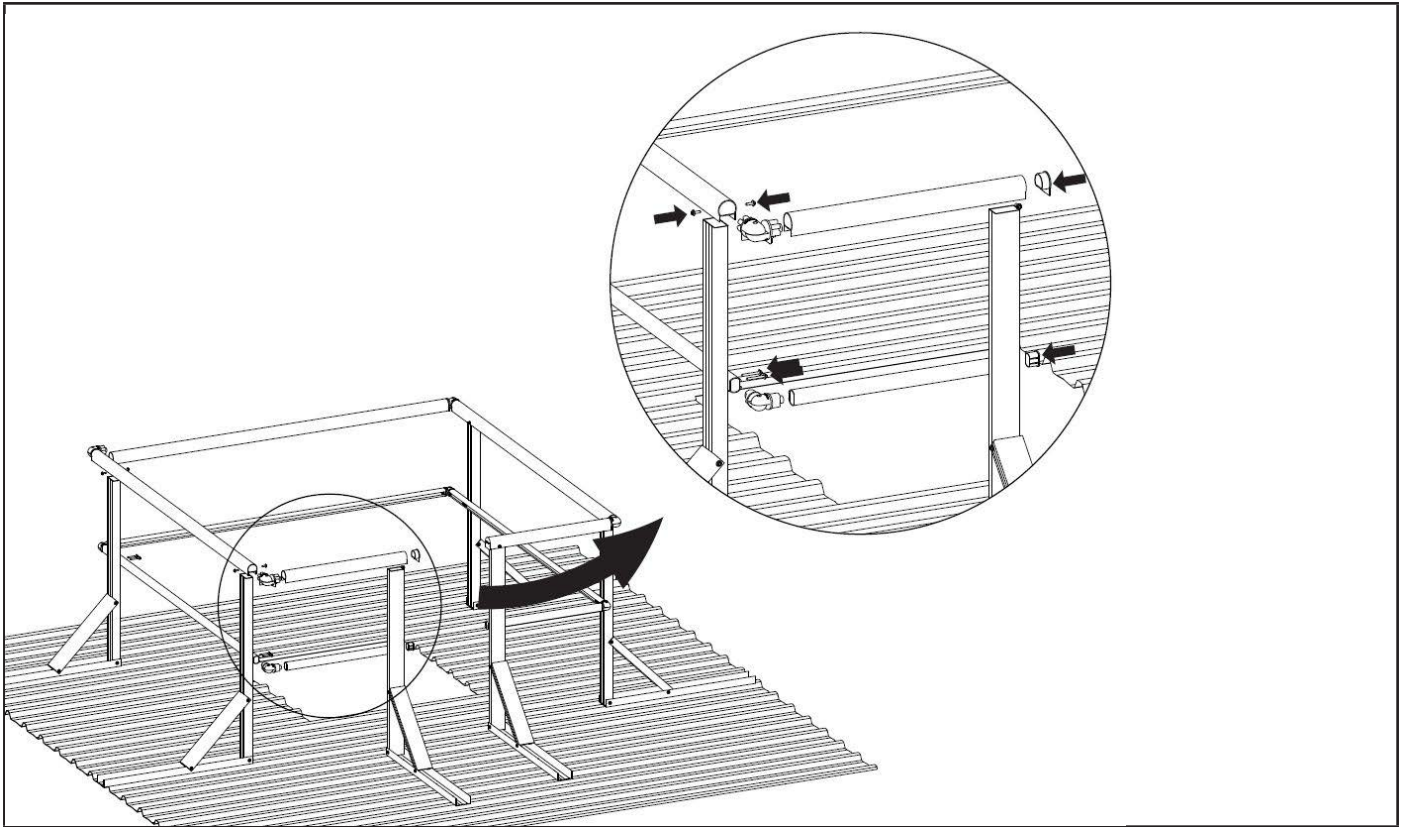

Fix the handrail, middle rail and corners. Install the rail end caps.

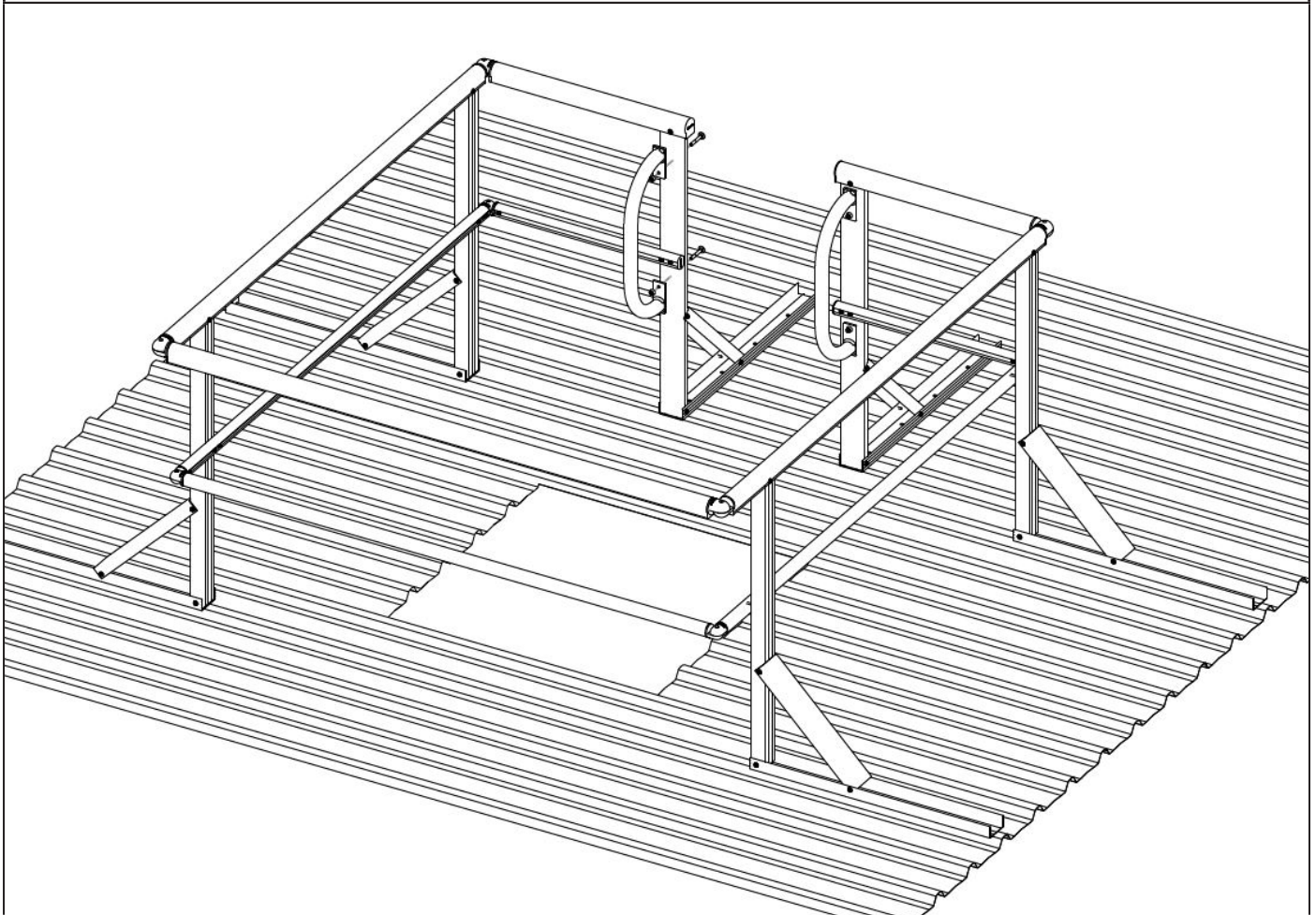

Fix each grab rail with 2x M8x60mm cup head bolt.

# 10 Roof Stairs

## 10.1 Installation

FIGURE 75

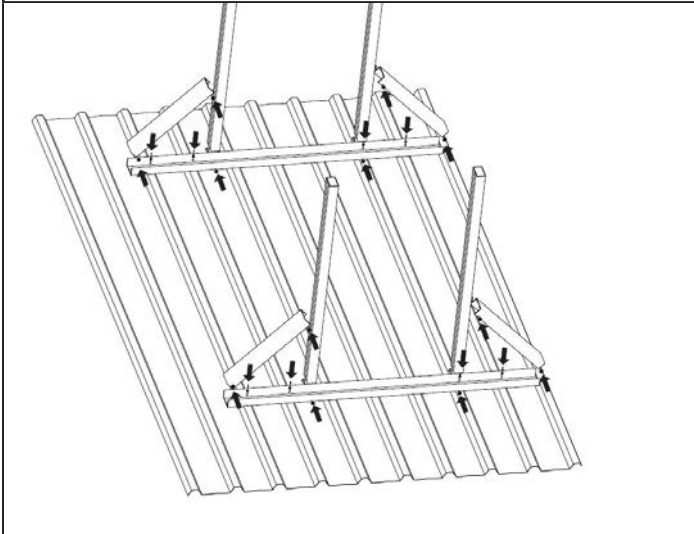

1. Assemble the guardrail post kits as per Section 4.11 and fix to the roof using 5mm rivets. Ensure the distance between the post kits is as specified in Section 3.1.4.

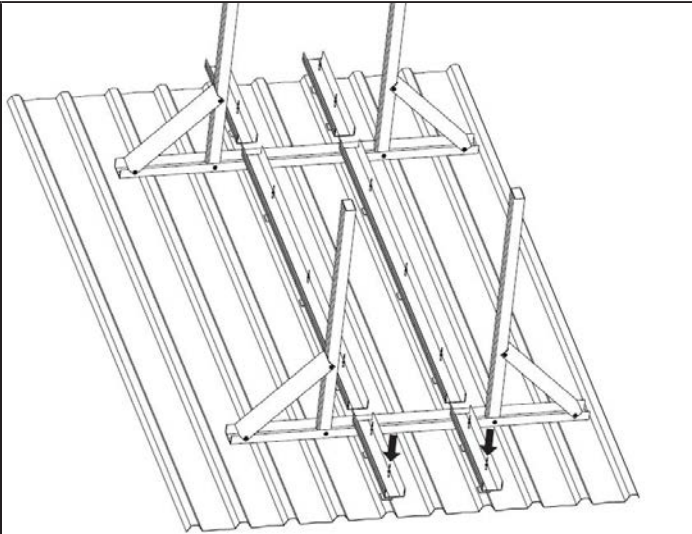

2. Measure the distance between the post kits and cut the supplied channel to length. Small sections of channel may need to be cut for the ends of the stairway, depending on the install location. Fix the channels to the roof using 5mm tri-fold rivets and foam tape. Fixings shall be no greater than 600mm apart.

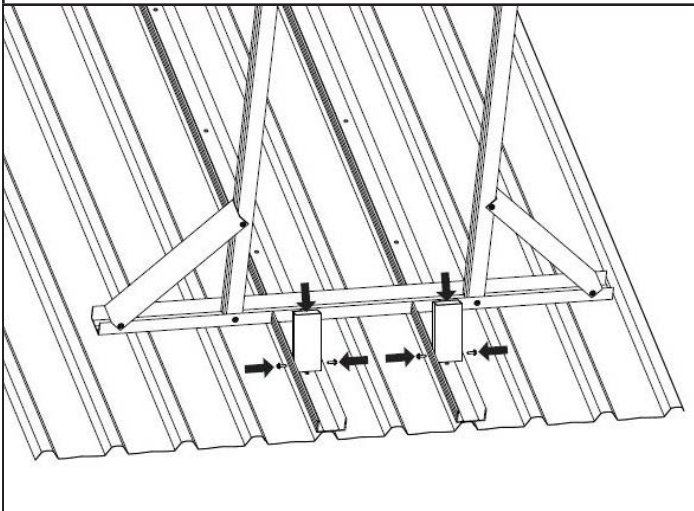

3. Starting at the base of the stairway, fix the RHS into the base channel using 4x 20mm tek screws. Ensure that the RHS is vertical.

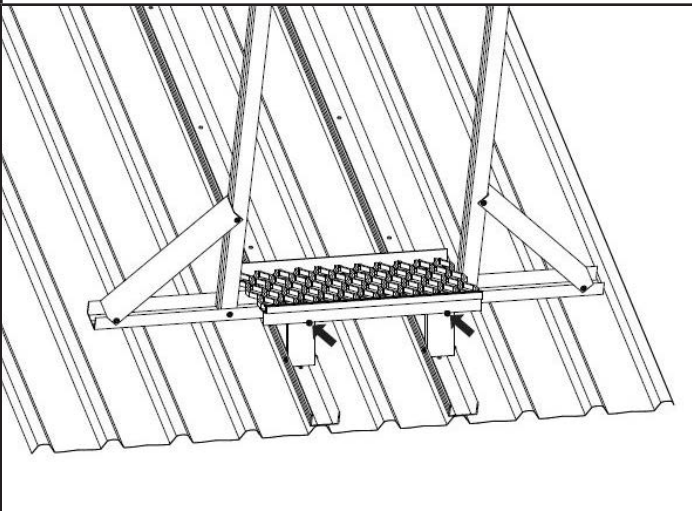

4. Rest the front of the step (with yellow bar) on the RHS and fix with 2x 20mm tek screws.

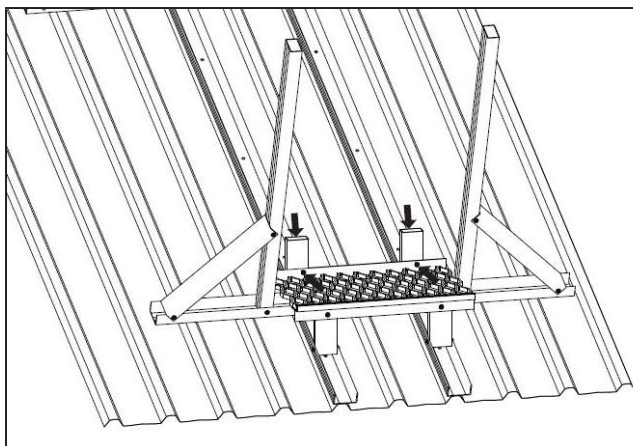

5. Fix the next 2 RHS sections to the back side of the step and to the base channel.

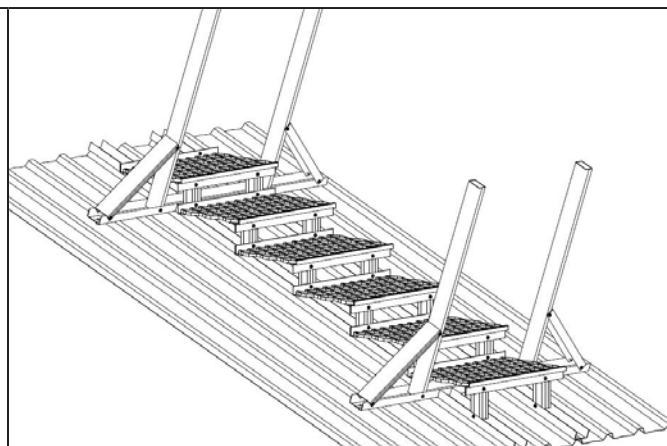

6. Repeat steps 4 and 5 until stairway is complete.

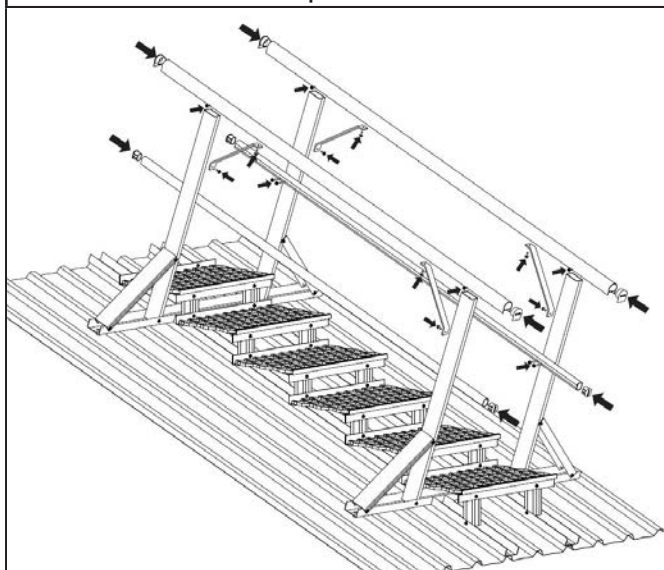

7. Assemble handrail and kneerail to the posts. Ensure that handrail braces are used on either end of the guardrail.

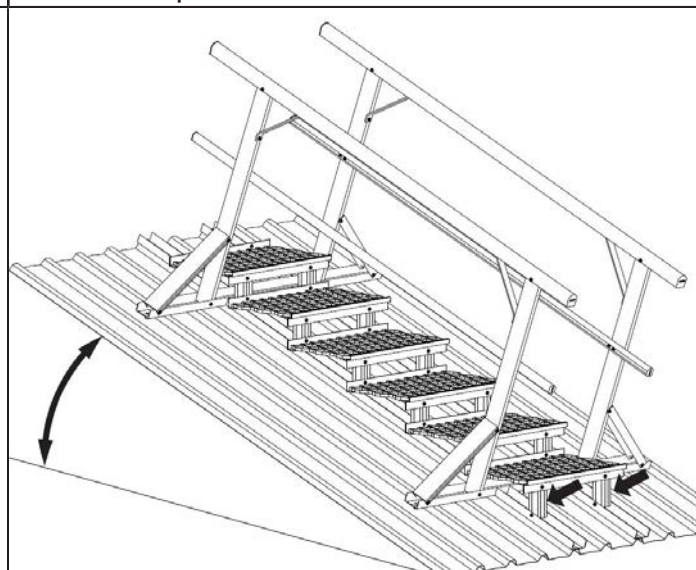

8. In some cases where the pitch of the roof cannot be determined prior to ordering, the RHS uprights will need to be cut on site. Figure 76 should be used as a guide.

**FIGURE 76**

Angle	Cut Length (mm)	Angle	Cut Length (mm)
21	156	34	208
22	163	35	215
23	170	36	175
24	176	37	181
25	183	38	186
26	190	39	192
27	164	40	198
28	170	41	205
29	176	42	211
30	182	43	218
31	189	44	225
32	195	45	232
33	202		

## 10.2 Joining Walkway

When joining walkway to the lower end of walkway stairs, the walkway shall be placed below the final step. Ensure the first rise (walkway to stair) is equal to the other stair rises.

When joining walkway to the upper end of walkway stairs, the walkway shall be placed to either side level with the top step. This will ensure the final rise in the set is accurate.

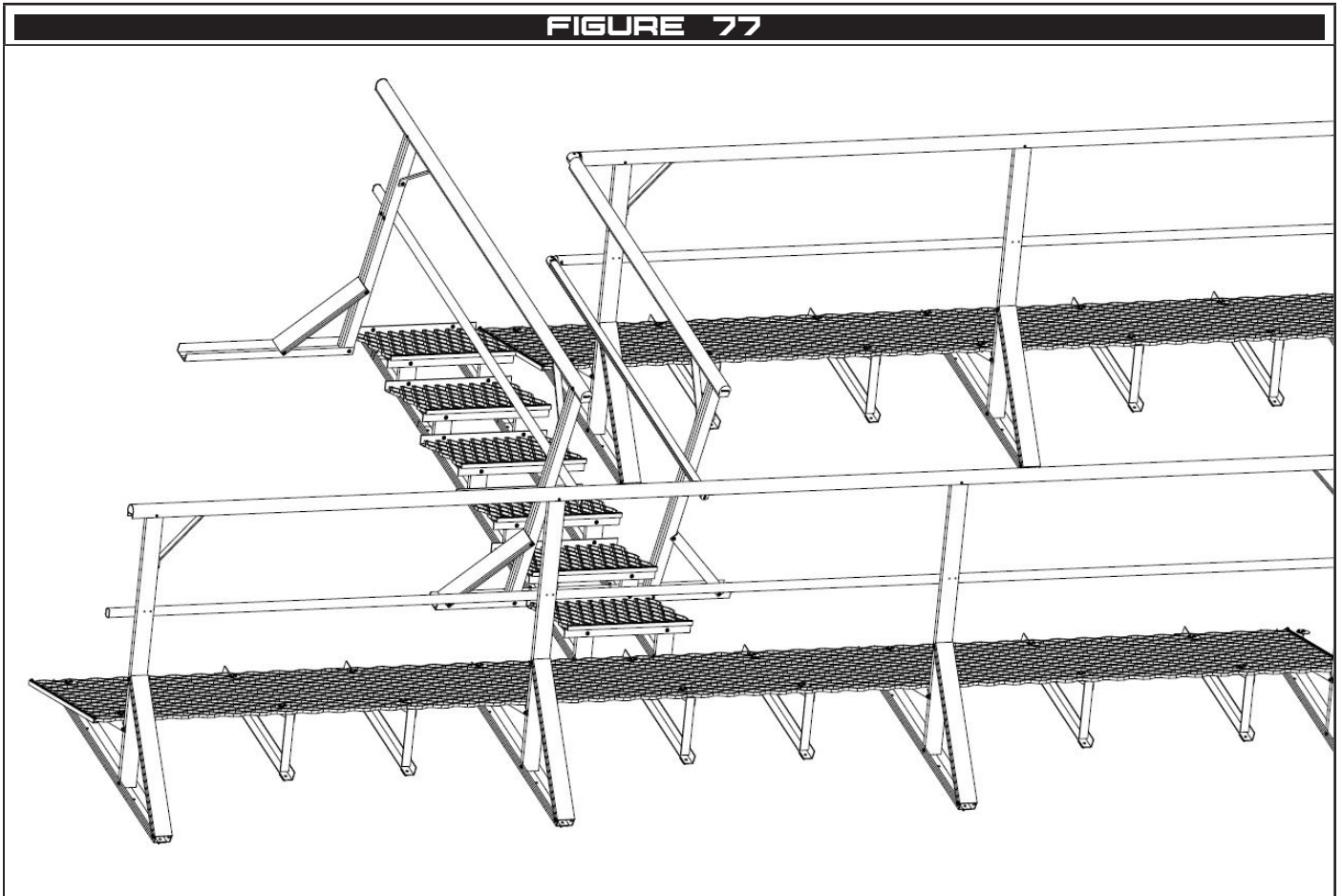

# 11 Steps

FIGURE 78

	
<p>1. If required cut the legs to the desired length</p> <p>⚠ <b>The step height shall not be greater than 300mm.</b></p> <p>⚠ <b>Step shall be level as per Section 3.2.8 and 3.2.9.</b></p>	<p>2. Place the four legs in the internal corners of the step platform, ensure that the long edge of the legs are facing the front edge of the platform. Install two 20mm tek screws on the front edge and one into the side of the platform into the legs.</p>
	
<p>3. Install two lengths of angle on the bottom of the legs. Ensuring that each length of angle crosses the front two and back two legs respectively. Place two 20mm tek screws through the lengths of angle into each leg.</p>	<p>4. Place three rivets and three foam squares along both lengths of angle.</p>

FIGURE 79



1. If required cut the legs to the desired length

⚠ **The step height shall not be greater than 300mm.**

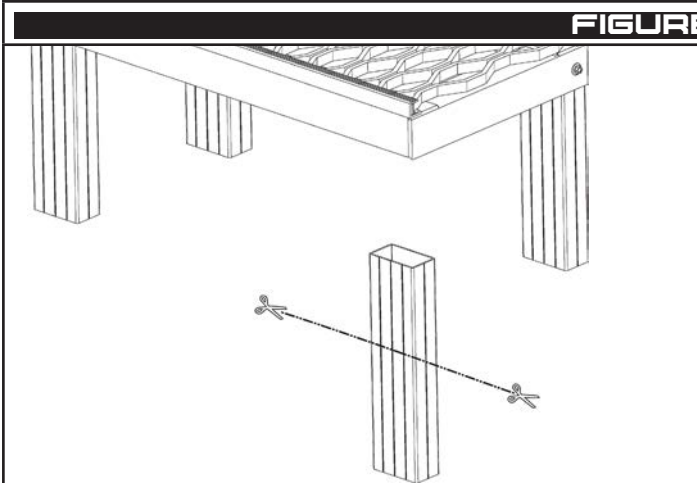
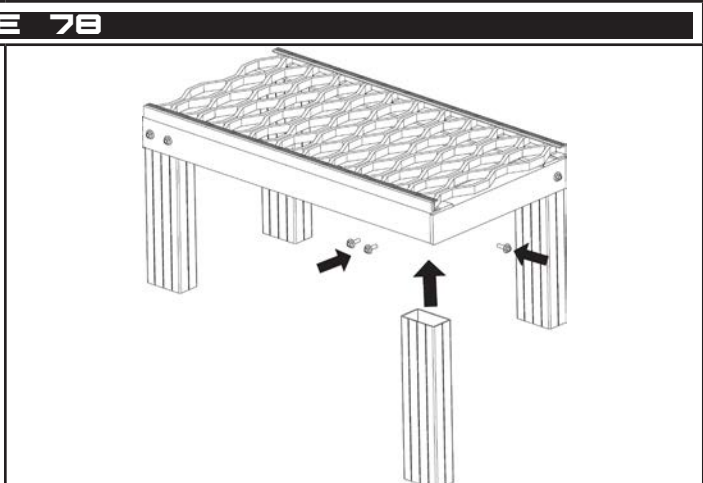
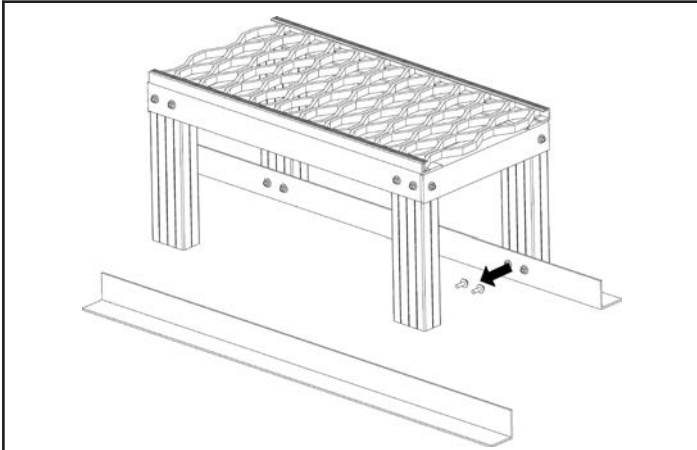
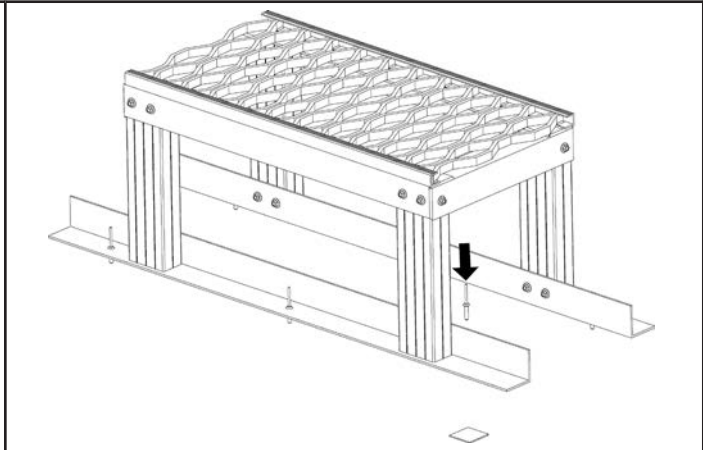
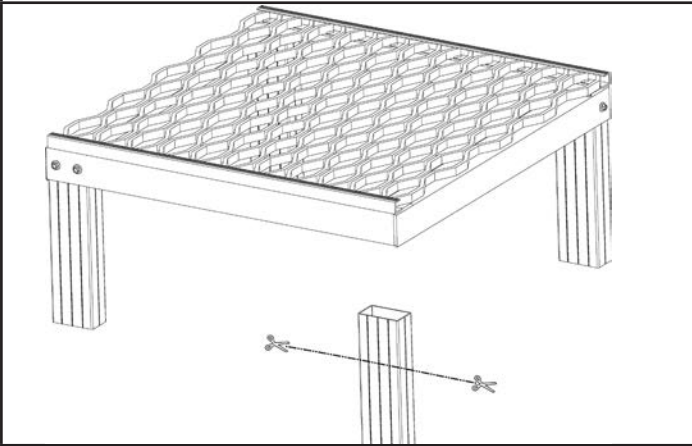
⚠ **Step shall be level as per Section 3.2.8 and 3.2.9.**

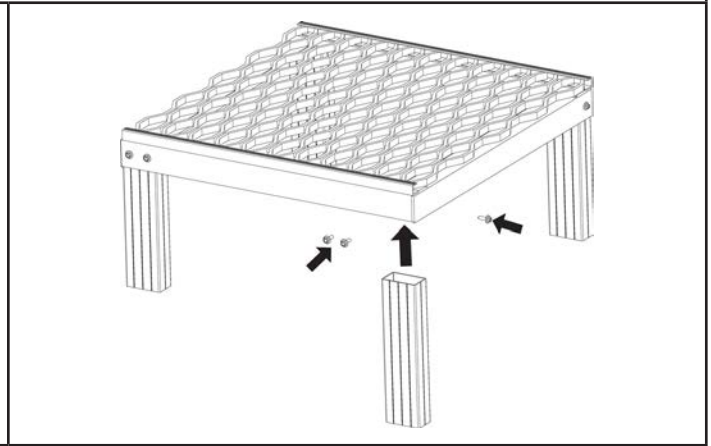

2. Place the four legs in the internal corners of the step platform, ensure that the long edge of the legs are facing the front edge of the platform. Install two 20mm tek screws on the front edge and one into the side of the platform into the legs.

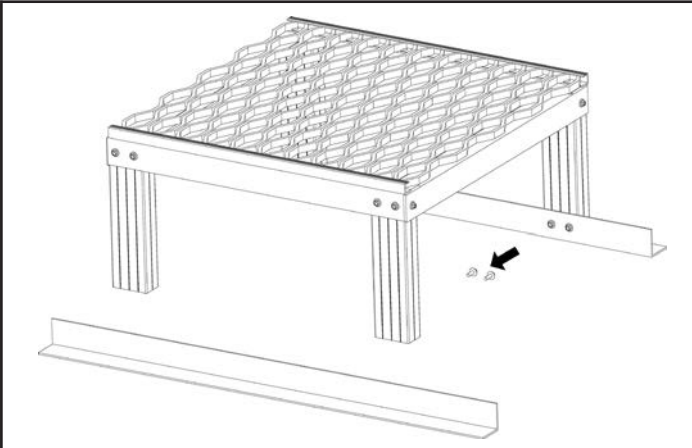

3. Install two lengths of angle on the bottom of the legs. Ensuring that each length of angle crosses the front two and back two legs respectively. Place two 20mm tek screws through the lengths of angle into each leg.

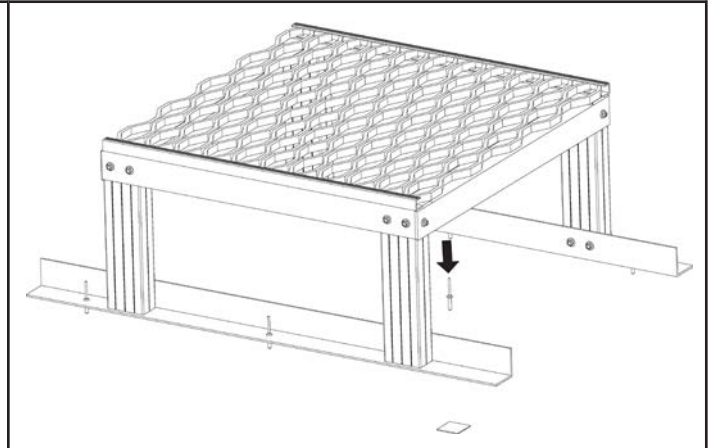

4. Place three rivets and three foam squares along both lengths of angle.

**FIGURE 80**

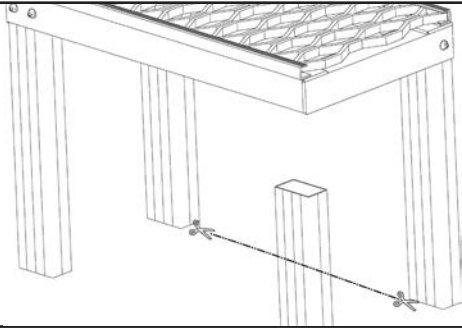

1. If required cut the legs to the desired length

⚠ **The height of the top step shall not be greater than 450mm**

⚠ **Each rise shall be equal to within 5mm.**

⚠ **Step shall be level as per Section 3.2.8 and 3.2.9.**

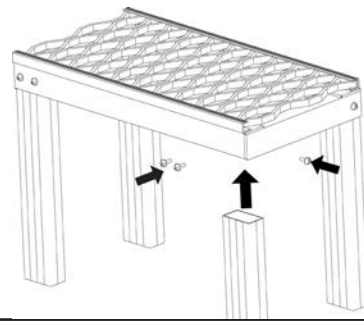

2. Place the four longer legs in the internal corners of the step platform, ensure that the long edge of the legs are facing the front edge of the platform. Install two 20mm tek screws on the front edge and one into the side of the platform into the legs.

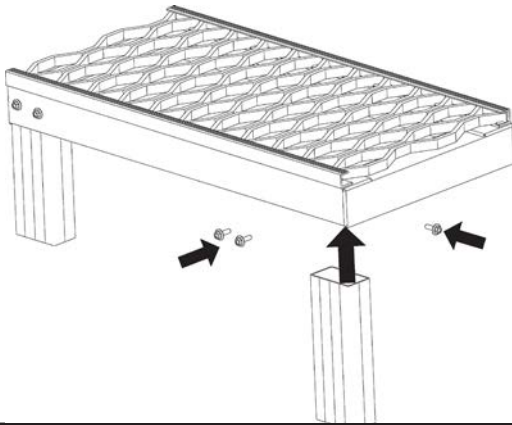

3. Place the two shorter legs in the internal corners of the step platform, ensure that the long edge of the legs are facing the front edge of the platform. Install two 20mm tek screws on the front edge and one into the side of the platform into the legs.

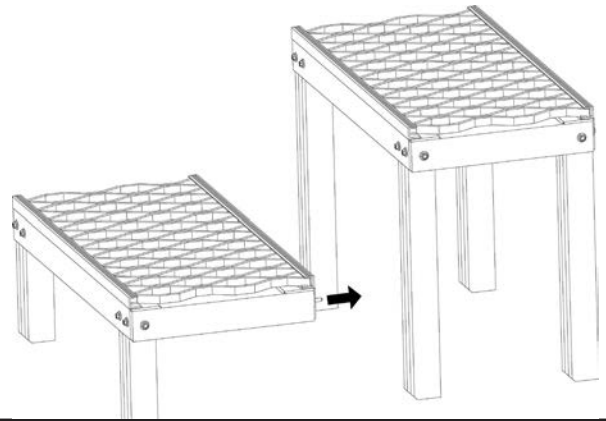

4. Screw the step platform assemblies together with a 20mm tek screw through the lower step platform in to the front two legs of the top step platform.

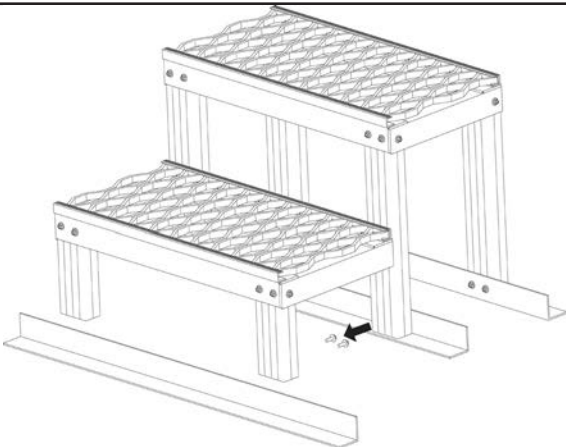

5. Install three lengths of angle on the bottom of the legs. Ensuring that each length of angle crosses the pairs of legs. Place two 20mm tek screws through the lengths of angle into each leg.

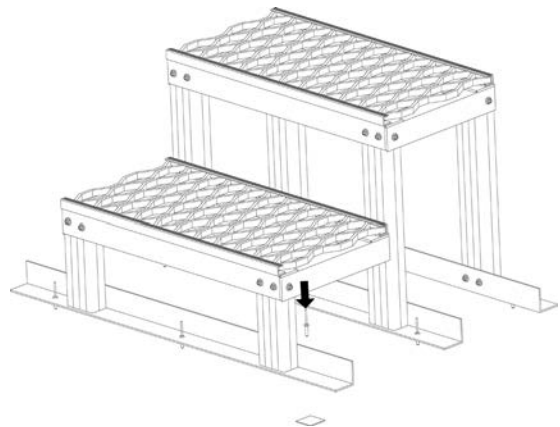

6. Place three rivets and three foam squares along each length of angle.

**FIGURE 81**

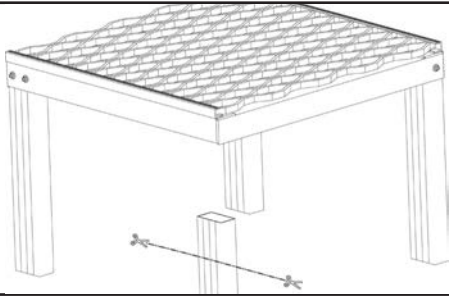

1. If required cut the legs to the desired length

⚠ **The height of the top step shall not be greater than 450mm**

⚠ **Each rise shall be equal to within 5mm.**

⚠ **Step shall be level as per Section 3.2.8 and 3.2.9.**

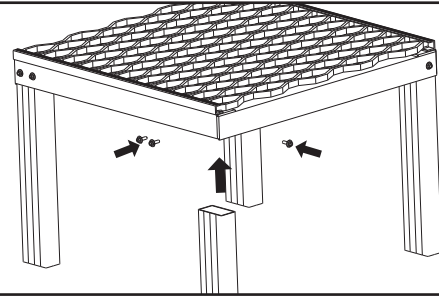

2. Place the four longer legs in the internal corners of the step platform, ensure that the long edge of the legs are facing the front edge of the platform. Install two 20mm tek screws on the front edge and one into the side of the platform into the legs.

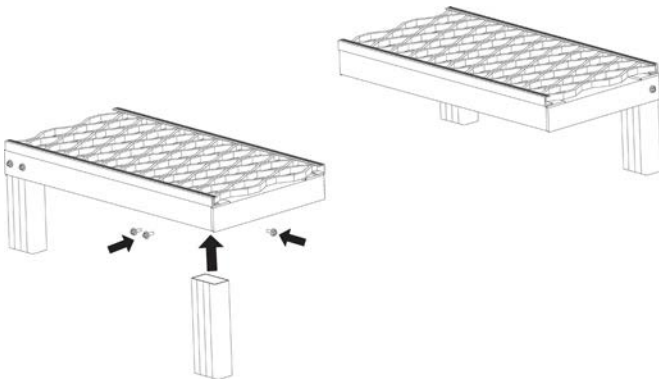

3. Place the two shorter legs in the internal corners of the step platform, ensure that the long edge of the legs are facing the front edge of the platform. Install two 20mm tek screws on the front edge and one into the side of the platform into the legs. Repeat for second step platform.

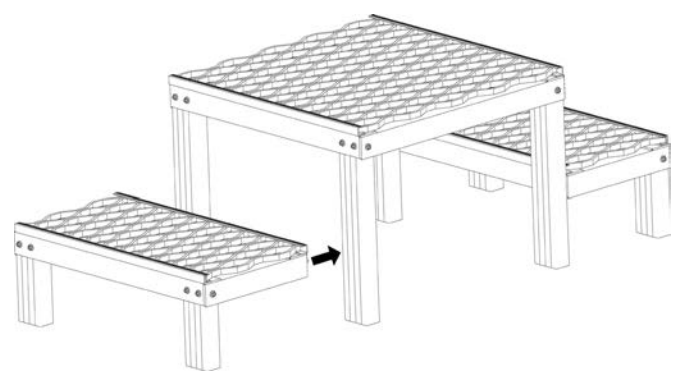

4. Screw the step platform assemblies together with a 20mm tek screw through the lower step platform in to the front two legs of the top step platform. Repeat for the second step platform.

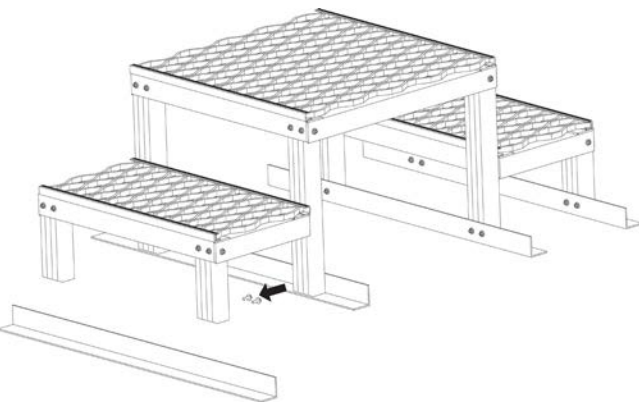

5. Install four lengths of angle on the bottom of the legs. Ensuring that each length of angle crosses the pairs of legs. Place two 20mm tek screws through the lengths of angle into each leg.

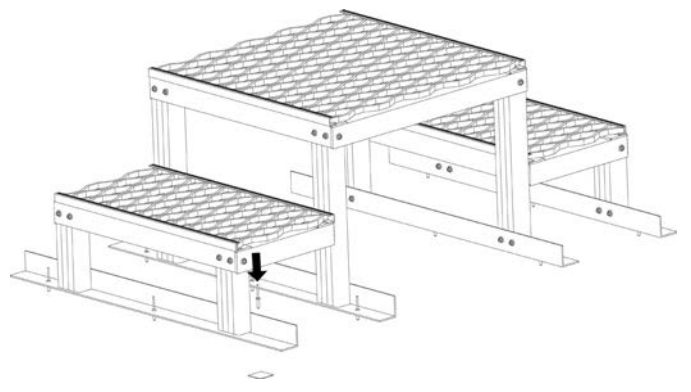

6. Place three rivets and three foam squares along each length of angle.

## 12 Clamp Fixings

### 12.1 General

12.1.1 All Clamp fasteners shall be tightened to 15Nm with a 6mm hex key

### 12.2 Clamps

#### 12.2.1 Kliplok 700

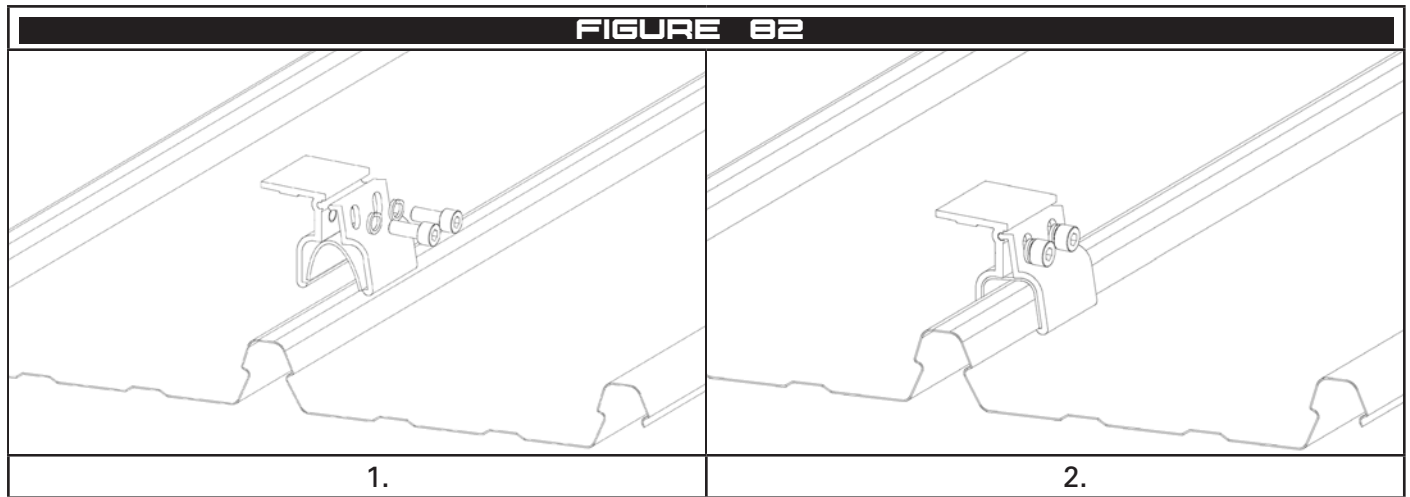

#### 12.2.2 Kliplok 406

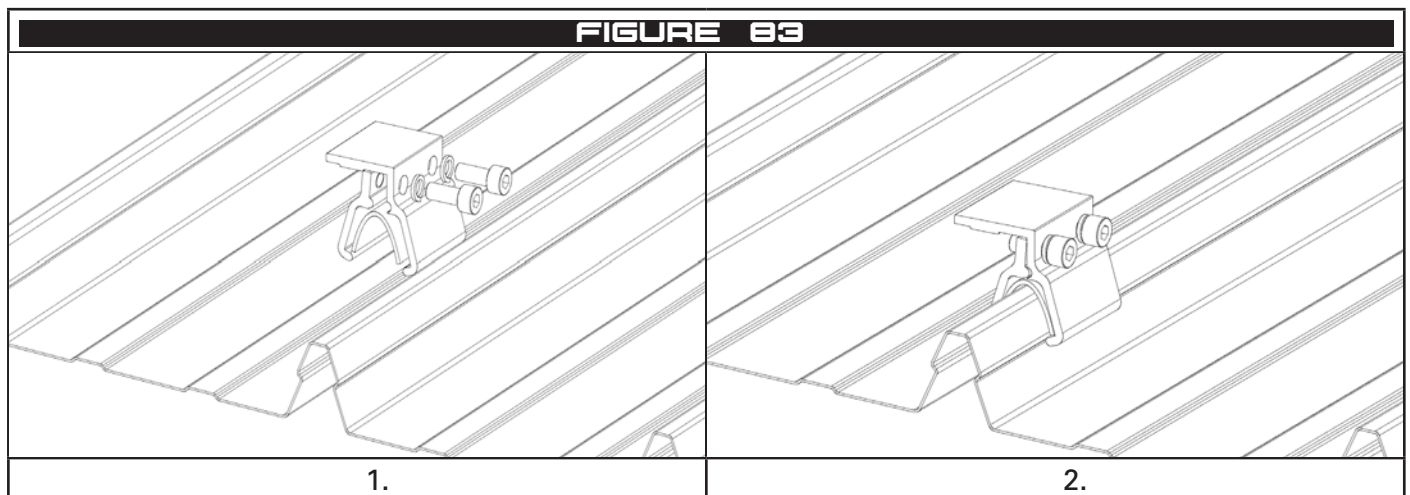

#### 12.2.3 KingZip and KalZip

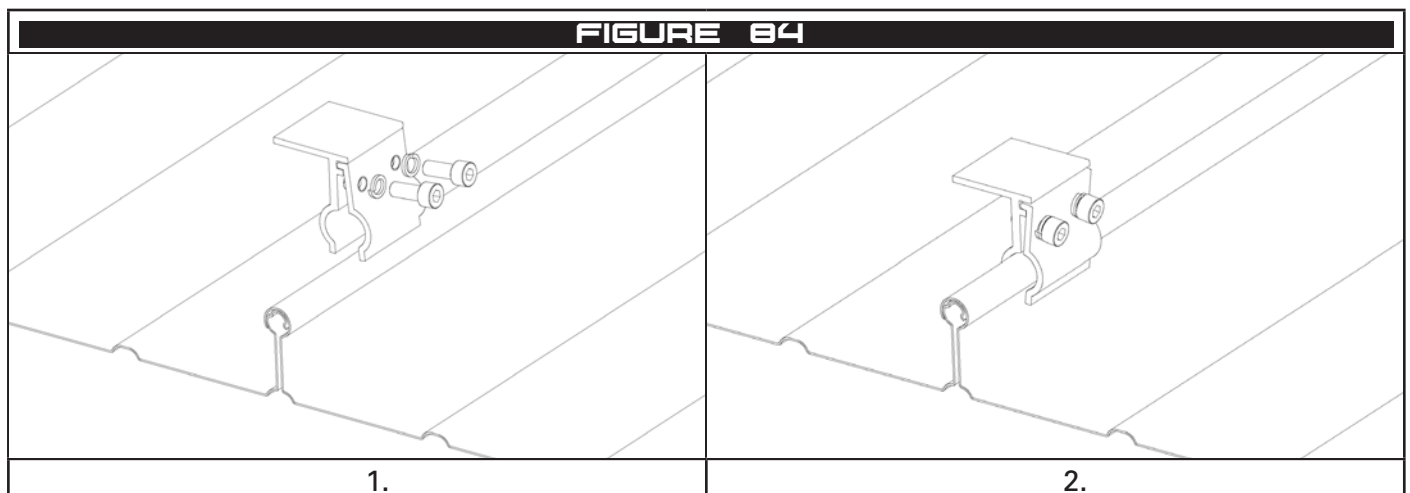

## 12.2.4 Standing Seam

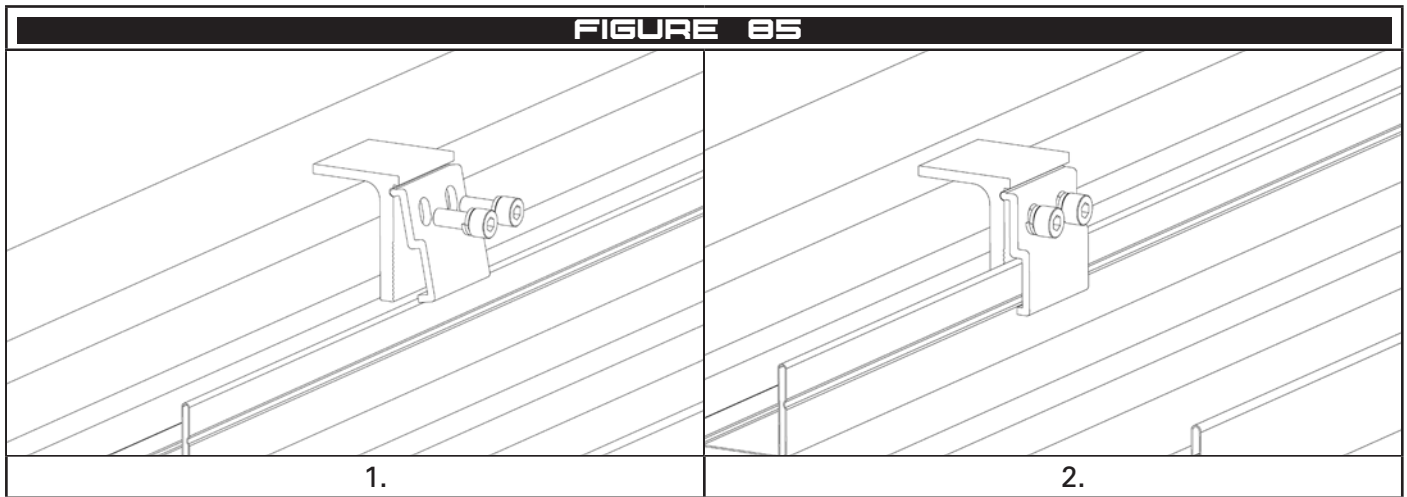

## 12.3 Installations

### 12.3.1 Walkway Across Seams

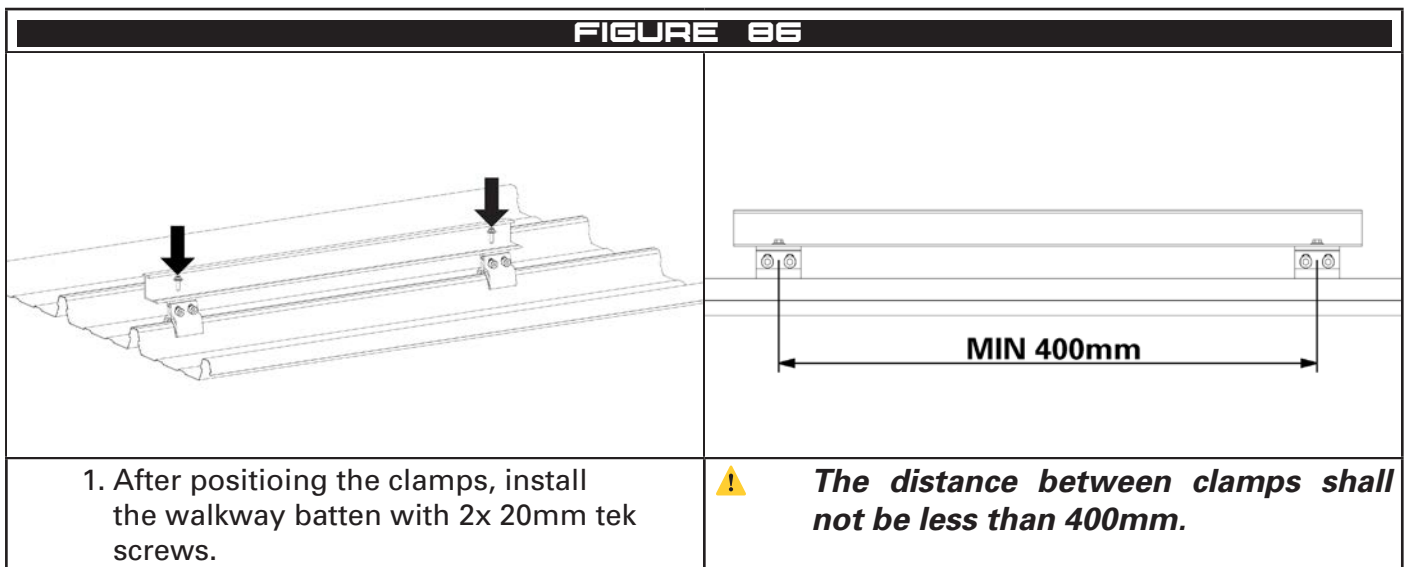

### 12.3.2 Walkway Along Seams

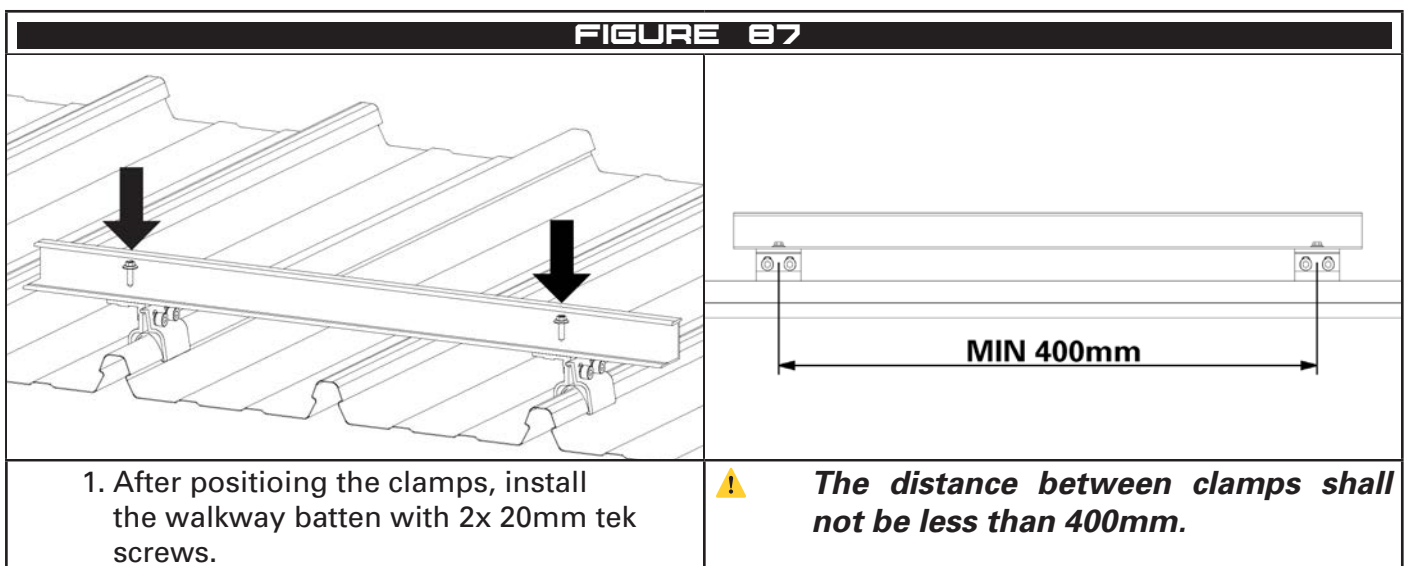

### 12.3.3 Walkway Long Span

**FIGURE 88**

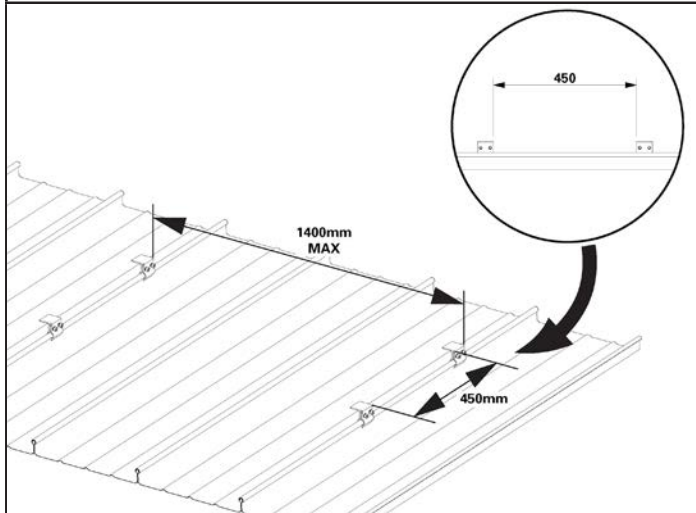

1. Install 2 clamps on one seam spaced at 450mm apart. In the direction of travel, clamps shall be installed on seams at spacings of no greater than 1400mm.

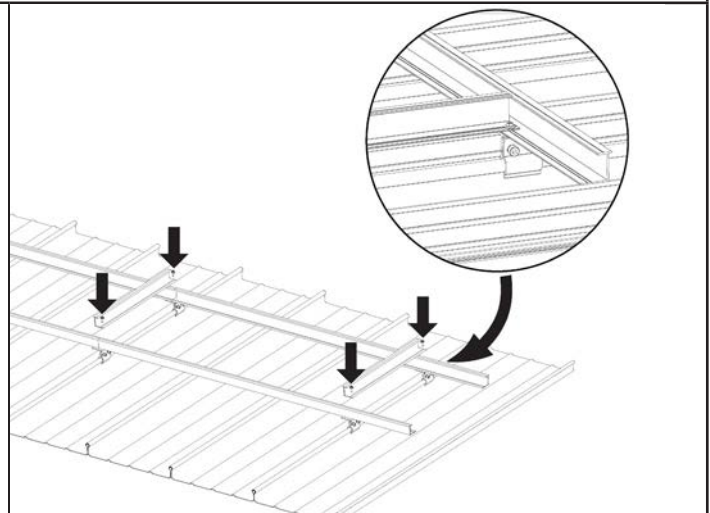

2. Rest the long lengths of the walkway batten on top of the clamps in the direction of the walkway. It is preferred that the end of the battens terminate on top of a clamp. A 500mm cross batten should be fixed at each clamp location through the side batten and clamp

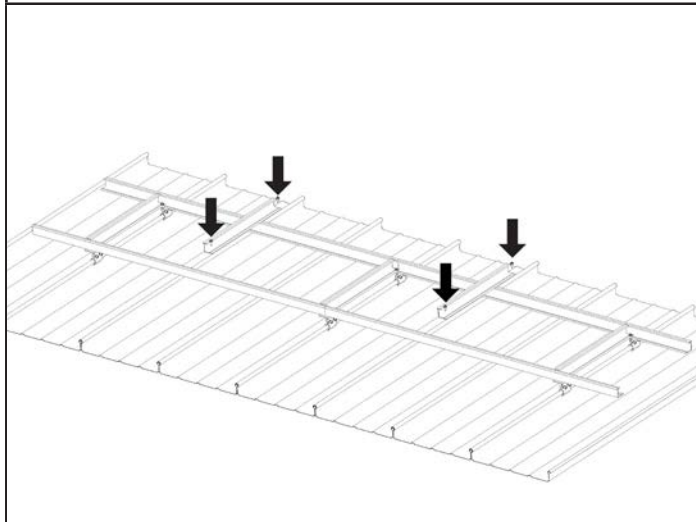

3. 500mm cross battens should be installed with 20mm tek screws at the midspan between clamp locations (approximately 600mm).

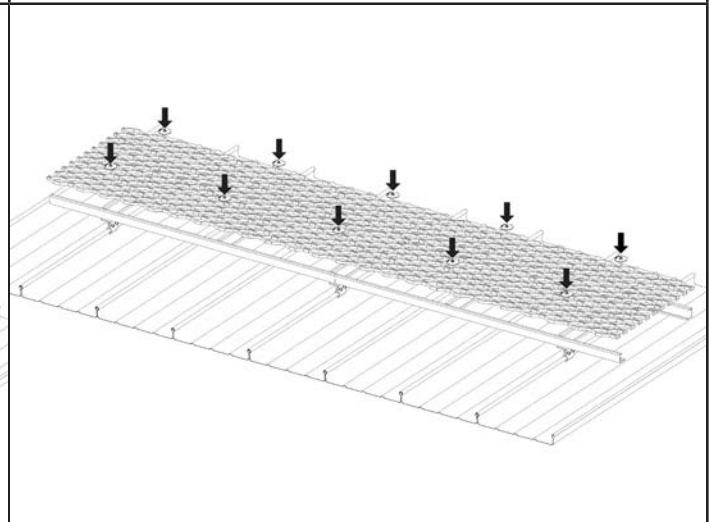

4. Install the walkway onto the battens.

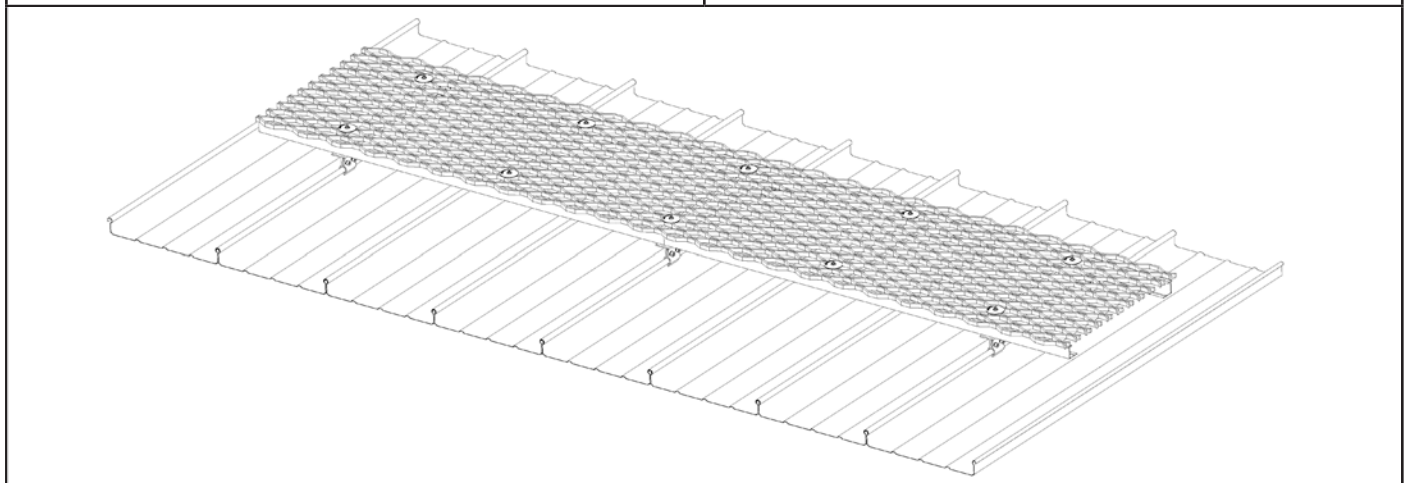

### 12.3.4 Single Guardrail

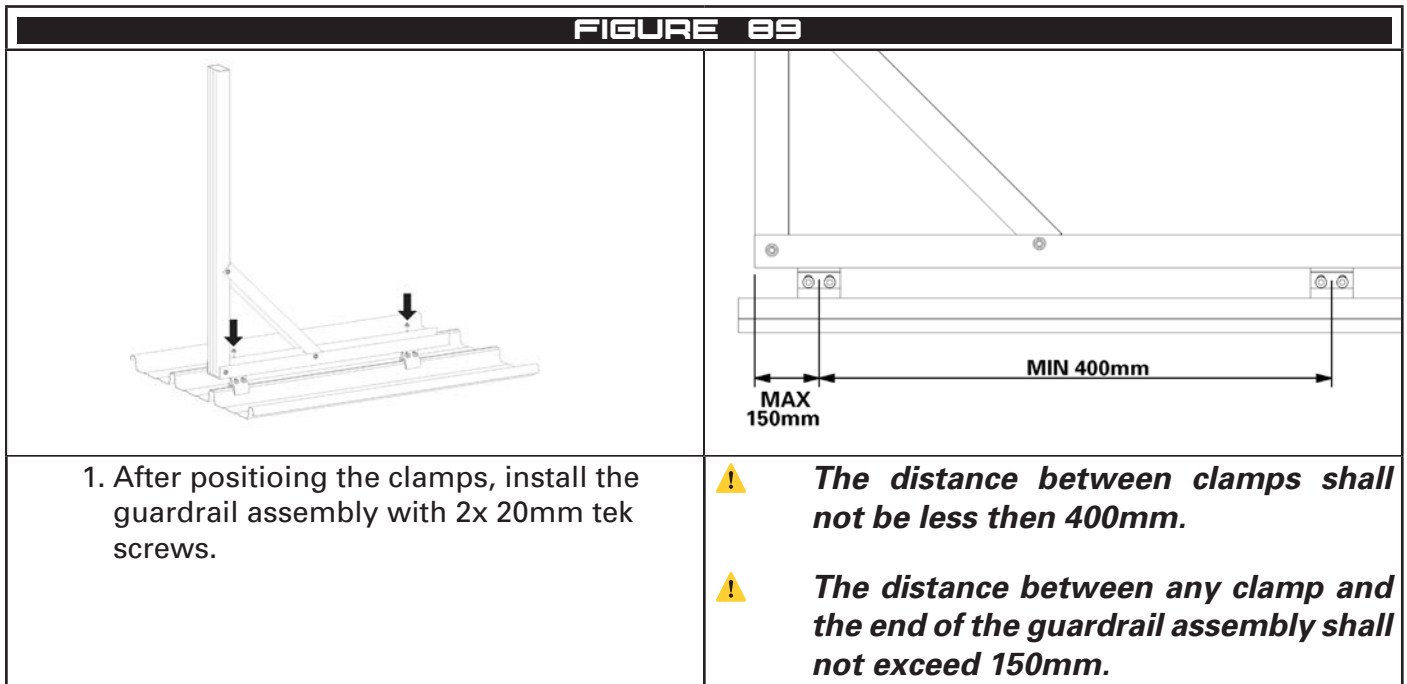

### 12.3.5 Double Guardrail

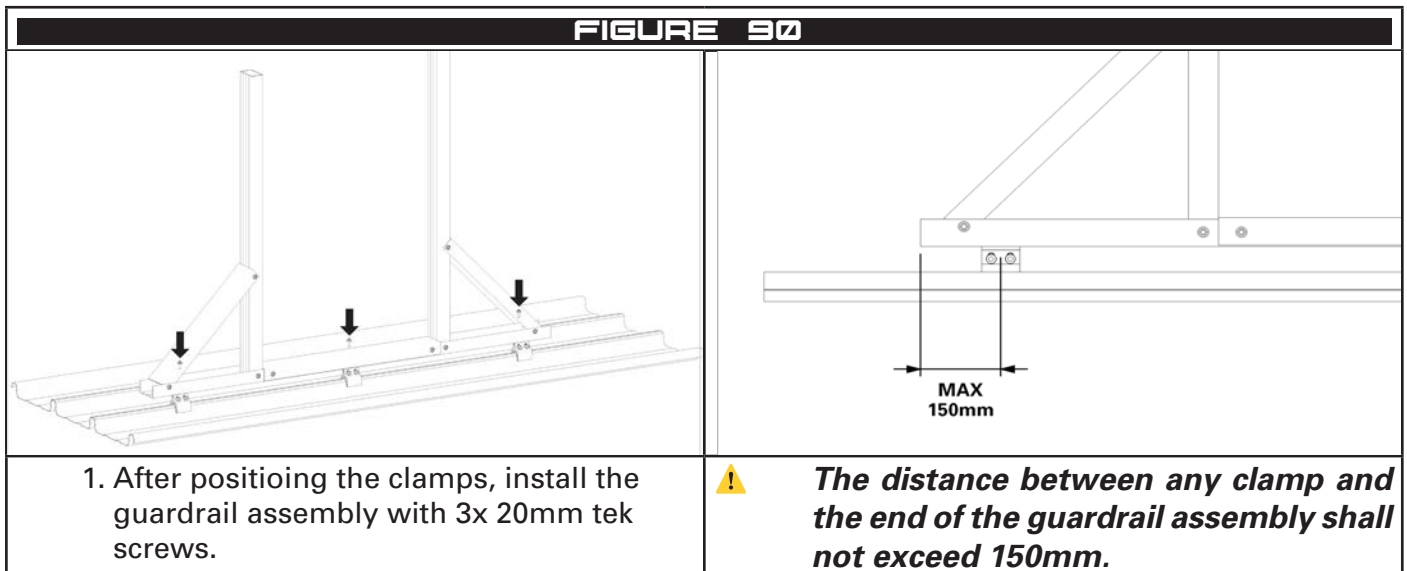

## 13 Tools

### 13.1 Middle Rail Spacer

The Middle Rail Spacer tool can be used to hang the middle rail from the handrail whilst it is being fixed to ensure the requirements of Section 3.2.5 are met.

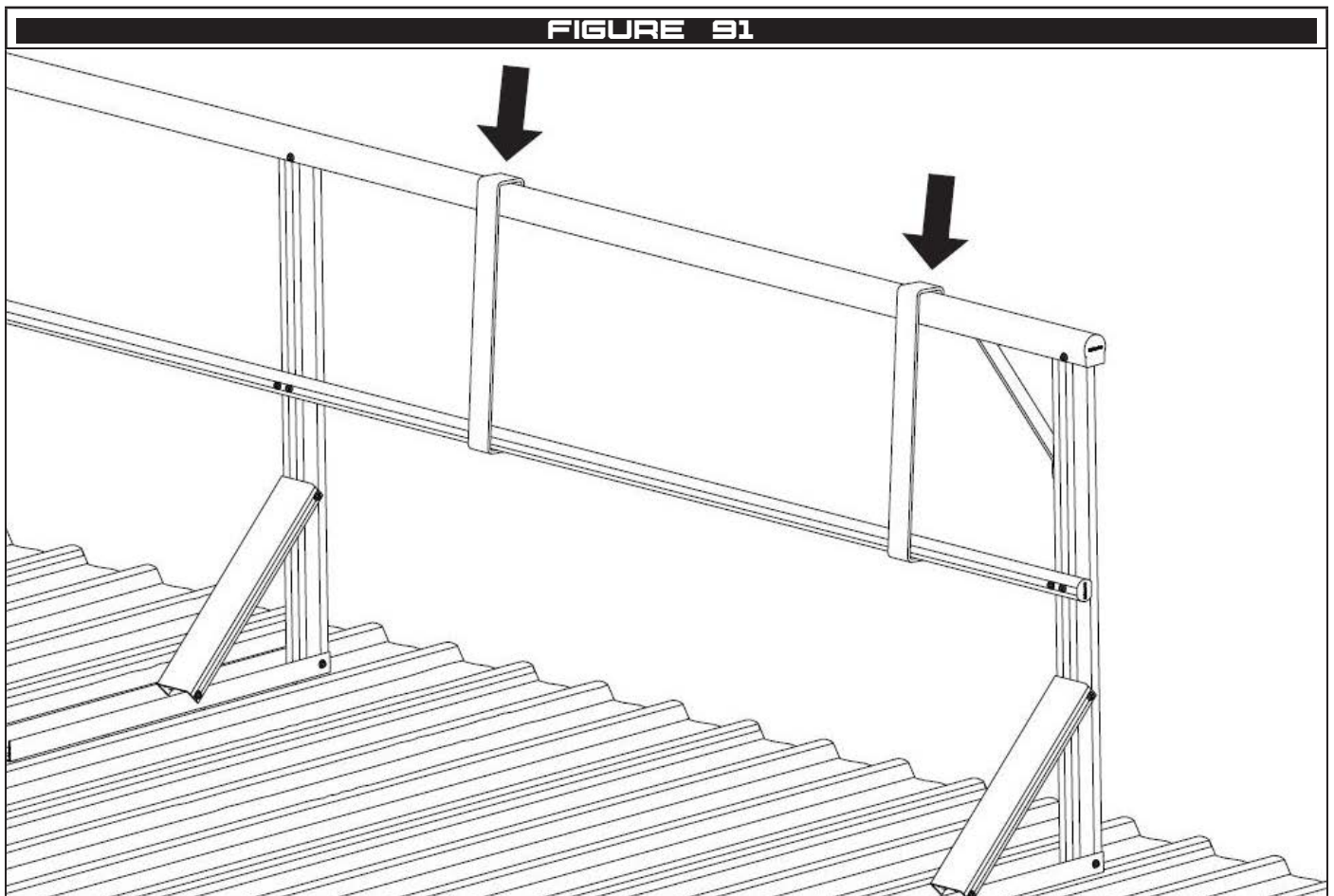

## 14 Inspection

### 14.1 Inspection Period

All FastFit access systems shall be inspected every 12 months by a competent height safety installer.

INSPECTION RECORD			
Product Code		Date of Manufacture	
Serial or Batch No.		Date of Install	
Inspector		Date of Inspection	
PROCEDURE	INSPECTION	USER	COMPETENT PERSON
<b>SEE SECTION 3.1 ON PAGE 12</b>	Check the requirement of the applicable section have been met.	<input type="checkbox"/>	<input type="checkbox"/>
	Comments:		
<b>SEE SECTION 3.2 ON PAGE 15</b>	Check the requirement of the applicable section have been met.	<input type="checkbox"/>	<input type="checkbox"/>
	Comments:		
<b>SEE SECTION 3.3 ON PAGE 20</b>	Check the requirement of the applicable section have been met.	<input type="checkbox"/>	<input type="checkbox"/>
	Comments:		
<b>SEE SECTIONS 4 - 9</b>	Inspect the applicable installation procedure has been followed for each components of the system.	<input type="checkbox"/>	<input type="checkbox"/>
	Comments:		
<b>SEE SECTION 3.3.5 ON PAGE 20</b>	Inspect the system has been labelled and the label is legible.	<input type="checkbox"/>	<input type="checkbox"/>
	Comments:		

# Warranties

## EXTRACT: SAFETYLINK PTY LTD STANDARD TERMS AND CONDITIONS

- 1.1 To the extent permitted by law all implied conditions, warranties and undertakings are expressly excluded.
- 1.2 Except as provided in this clause the Company shall not be liable for any loss or damage, whether direct or indirect (including consequential losses or damage) arising out of any breach of contract by the Company or any negligence of the Company, its employees or agents.
- 1.3 Should the Company be liable for a breach of a guarantee, condition or warranty implied by the Australian Consumer Law (not being a guarantee, condition or warranty implied by sections 51, 52 and 53 of that Law) then its liability for a breach of any such condition or warranty express or implied shall be limited, at its option, to any one or more of the following.
- A in case of Goods
- I the replacement of the Goods or the supply of equivalent Goods.
  - II the repair of the goods,
  - III the payment of the cost of replacing the Goods or acquiring equivalent Goods.
  - IV the payment of the cost of having the Goods repaired. Provided that any such Goods are returned to the Company by the Purchaser at the Purchaser's expense.
- B in the case of services
- I the supply of the services again,
  - II the payment of the cost of having the services supplied again.
- 1.4 The Company is not liable for the costs of recovery of the Goods from the field, loss of use of the Goods, loss of time, inconvenience, incidental or consequential loss or damage, nor for any other loss or damage other than as stated above, whether ordinary or exemplary, caused either directly or indirectly by use of the Goods.
- 1.5 The Company warrants that at the time of shipment, Products manufactured by it will be free from defects in material and workmanship. In the absence of a modified written warranty, the Company agrees to making good any such defects by repairing the same or at the Company's option by replacement, for a period of (1) one year from the date of shipment. This limited warranty applies provided that:
- a defects have arising solely from faulty materials or workmanship;
  - b the Products have not received maltreatment, inattention or interference;
  - c the Products have been installed in accordance with the Company's Installation Handbooks using only products supplied by the Company;
  - d accessories used with the Products are manufactured by or approved by the Company
  - e the Products are maintained in accordance with Australian Standard 1891.4 (section 9).
  - f you notify any claim under this warranty to SafetyLink in writing to the address below no later than 14 days after the event or occurrence concerning the produce giving rise to the claim and you pay all costs related to your claim.
- This warranty does not apply to any defects or other malfunctions caused to the Goods by accident, neglect, vandalism, misuse, alteration, modification or unusual physical, environment or electrical stress.
- Please note that the benefits to the purchaser (as a consumer) given by this warranty are in addition to your other rights and remedies under the Australian Consumer Law. Our goods come with guarantees that cannot be excluded under the Australian Consumer Law. You are entitled to a replacement or refund for a major failure and compensation for any other reasonably foreseeable loss or damage. You are also entitled to have the goods repaired or replaced if the goods fail to be of acceptable quality and the failure does not amount to a major failure.
- 1.6 If any goods are not manufactured by the Company, the guarantee of the manufacturer thereof shall be accepted by the Purchaser as the only express warranty given in respect of the goods.
- 1.7 Except as provided in this clause 11, all express and implied warranties, guarantees and conditions under statute or general law as the merchantability, description, quality, suitability or fitness of the Products for any purpose or as to design, assembly, installation, materials or workmanship or otherwise are hereby expressly excluded (to the extent to which they may be excluded by law).

PLEASE SEE SAFETYLINK PTY LTD FULL STANDARD TERMS OF CONDITIONS OF SALE FOR FURTHER REFERENCE.



SafetyLink Pty Ltd | ABN 83 081 777 371 | [www.safetylink.com](http://www.safetylink.com)

Head Office: 54 Bonville Ave, Thornton, 2322, NSW, Australia

+64 2 4964 1068 | 1300 789 545

Asia-Pacific/The Americas | [info@safetylink.com](mailto:info@safetylink.com)

Europe/Africa/Middle East | [europe.sales@safetylink.com](mailto:europe.sales@safetylink.com)

Northern Europe | [uk.sales@safetylink.com](mailto:uk.sales@safetylink.com)