

USER MANUAL

SAFETYLINK EQUIPMENT SELECTION, USE AND MAINTENANCE

TO BE READ IN CONJUNCTION WITH **SITE SPECIFIC** INFORMATION

SafetyLink is an innovative anchor company achieving success and keeping you safe whilst working at heights.

- 🔗 ROOF ANCHORS
- 🔗 HORIZONTAL LIFELINES
- 🔗 PERMANENT LADDERS
- 🔗 LADDER STABILISERS
- 🔗 TEMPORARY ANCHOR



Read entire handbook before installing SafetyLink products. All products must be installed in accordance with SafetyLink's installation handbook, using only products supplied by SafetyLink Pty Ltd. Failure to follow all warnings and instructions may result in a serious injury or death.



SafetyLink Pty Ltd
AU: 1300 789 545
INT: +61 2 4964 1068
FAX: +61 2 4964 1069
info@safetylink.com

www.safetylink.com

TABLE OF CONTENTS

SCOPE	3
LEGISLATION.....	4
RISK ASSESSMENT AND FALL PREVENTION.....	5
USE OF SAFETYLINK SYSTEM	6
USAGE INFORMATION	6
LATERAL SWING (THE PENDULUM EFFECT).....	6
FALL-ARREST AND FALL RESTRAINT	8
OBJECTS FALLING FROM HEIGHTS	9
ELECTRICAL HAZARDS	9
USER COMPETENCY.....	9
NUMBER OF USERS	9
SYSTEM INFORMATION PLATES LABELS AND SIGNS.....	9
SAFETYLINK LADDER STABILISERS	10
INSTALLATION FOR METAL ROOFS – UNDER ROOF SHEETING	10
INSTALLATION FOR METAL ROOFS – ON TOP OF ROOF SHEETING	10
INSTALLATION FOR TILED ROOFS.....	11
WALL MOUNTED LADDERLINK.....	11
FIXING TO TIMBER WALL/PARAPET	11
FIXING TO CONCRETE WALL/PARAPET	11
SAFETYLINK ANCHORAGES – PROGRESSING ALONG SYSTEM – FIGURE 3	12
PROGRESSING ALONG THE ANCHOR SYSTEM	13
DISCONNECTING FROM THE ANCHOR SYSTEM	13
LIFELINE SYSTEM – HORIZONTAL SHUTTLES	14
CONNECTING TO THE LIFELINE (USING SAFELINK™ SHUTTLE)	14
CONNECTING TO THE LIFELINE (USING FROGLINE SHUTTLE).....	14
LIFELINE SYSTEMS IN USE.....	15
PROGRESSING ALONG THE LIFELINE	15
DISCONNECTING FROM THE CLASSIC SAFETYLINK LIFELINE.....	15
DISCONNECTING FROM THE FROGLINE LIFELINE	15
PERSONAL PROTECTIVE EQUIPMENT	15
LIFELINE SYSTEM – OVERHEAD SHUTTLE	16
CONNECTING TO THE LIFE LINE SYSTEM	16
PROGRESSING ALONG THE LIFE LINE SYSTEM	16
DISCONNECTING FROM THE LIFE LINE SYSTEM.....	16
SAFETYLINK PERMANENT LADDER SYSTEM	17
CONNECTING TO THE LINE.....	17
PROGRESSING ALONG THE LINE	17
DISCONNECTING FROM THE LINE	17
MAINTENANCE	18
SAFETYLINK LADDER STABILISERS.....	18
SAFETYLINK PERMANENT LADDER SYSTEMS	18
SAFETYLINK ANCHORAGES.....	19
SAFETYLINK LIFELINE SYSTEMS	20
ANCHORS AND LADDER STABILISERS INSTALLATION AND RECERTIFICATION CHECKLIST	21
LIFELINE AND LADDER STABILISERS INSTALLATION AND RECERTIFICATION CHECKLIST	24
PERMANENT LADDER SYSTEM INSTALLATION AND RECERTIFICATION CHECKLIST.....	29
EXPERT FALL PROTECTION PLANNING	31
IN CASE OF ACCIDENT	32



WARNINGS:

This supplement is a guide only and is not intended to substitute training courses in height safety and product installation.

Legislative requirements vary according to the region you live in please visit the appropriate workcover website for further information.

Individual situations vary considerably therefore you should seek appropriate legal advice if you need assistance on the application of law to your situation.

The **PURPOSE** of this supplement is:

- to outline the selection process of a SafetyLink System.
- to provide information about the safe use of the SafetyLink Systems.
- to make users aware of maintenance requirements of their SafetyLink System.
- to provide users with information about possible issues that may need to be addressed with a SafetyLink Height Safety System.

LEGISLATION

WARNINGS:

Legislative requirements vary according to the region you live in please visit the appropriate website for further information.

AUSTRALIA

SafeWork NSW (New South Wales)

P: 13 10 50

W: www.safework.nsw.gov.au

WorkSafe Victoria

P: 1800 136 089

W: www.worksafe.vic.gov.au

WorkCover Queensland

P: 1300 362 128

W: www.worksafe.qld.gov.au

SafeWork SA (South Australia)

P: 1300 365 255

W: www.safework.sa.gov.au

WorkSafe Tasmania

P: 1300 366 322

W: www.worksafe.tas.gov.au

Worksafe Western Australia

P: 1300 307 877

W: www.commerce.wa.gov.au/worksafe/

NT Worksafe (Northern Territory)

P: 1800 019 115

W: www.worksafe.nt.gov.au

WorkSafe (Australian Capital Territory)

P: 13 22 81

W: <http://www.worksafe.act.gov.au/>

NEW ZEALAND

WorkSafe (New Zealand)

P: 0800 030 040

W: www.worksafe.govt.nz/worksafe/

LEGISLATION:

- For legislative requirements contact the appropriate authority for your state.
- Specific height safety requirements exist under legislation, regulations and codes of practice for each state.
- The fundamental principle throughout is that employers and self employed persons must **provide a safe working environment** to maintain the health, safety and welfare of employees and other persons exposed to that working environment.
- Employees also have an obligation to take reasonable steps to protect their own health, safety and welfare and others in their working environment. If you need help to meet these obligations contact the appropriate authority for your state.

RISK ASSESSMENT AND FALL PREVENTION

RISK ASSESSMENT:

- Risk assessments should be conducted in consultation with workers for all work conducted irrespective of height, using the appropriate measures of control.
- All fall arrest systems and lifeline systems require a risk assessment prior to use.
- A fall rescue plan should also be developed prior to use.
- Workers using a fall arrest system or lifeline system should never work alone.

STEPS TO COMPLETE A RISK ASSESSMENT ON A PARTICULAR JOB:

1. Identify the hazards.
2. Assess the hazard determining how great the risk is, the likelihood and consequence of each hazard.
3. Make decisions on what can be done to control the risk, in order of the following:
 - Elimination (Eliminate the need to access the fall risk area).
 - Substitution (Provide alternative methods to access the point or item which avoids the risk of a fall for example a walkway).
 - Isolation (enclose fall risk area so that is cannot be reached).
 - Fall protection (provide personal protective equipment which either prevents a fall or reduces the risk or severity of a fall).
4. Implement a review process to reassess control measures and consider whether they are still appropriately controlling the risk.

CONTROL MEASURES FOR FALL PREVENTION:

While undertaking a risk assessment where there is risk associated with working at heights the following controls need to be implemented in order of hierarchy:

1. Provision and maintenance of a stable and secure fenced work platform, that is scaffolding equipment or other temporary work platform. If this is not practicable then;
2. Provision and maintenance of secure perimeter screen, fencing or handrails capable of preventing a fall from heights. If this is not practicable then;
3. Provision of other forms of physical restraint that are capable of arresting a fall.

It is important to be aware that there are risks associated with working at any elevated position. Therefore, there are no minimum requirements for implementation of the above hierarchy of control.

In determining the control measures to be implemented for fall prevention an employer is only allowed to use restraints or fall arrest devices where it is not reasonably practical to use scaffold or guardrail systems. Where restraint or fall arrest devices have been implemented documentation needs to be produced showing reasons why it was not practical to use scaffolding or guardrails.

USE OF SAFETYLINK SYSTEM

⚠ WARNINGS & HAZARDS

During installation you must be safe at all times.

Persons working at heights should not work alone. A person suspended mid air following a fall can suffer serious injury or death if a rescue is not implemented as quickly as possible.

- SafetyLink™ Systems are to be used only by people with necessary competence and training.
- When the SafetyLink™ System is exposed to a corrosive or extreme environment which could significantly reduce the working load of the SafetyLink™ System, the manufacturer or a competent height safety installer shall be consulted prior to such exposure.
- The building or structure for the anchorages should be assessed by an engineer, unless it is clear to a competent height safety installer that the structure is adequate.
- All safety procedures must be complied with in accordance with the current safety code(s) of practice(s) for working at heights. Ensure safety at all times by being attached to suitable anchor points and approved safety equipment or approved scaffolding.
- Inspect all personal protection equipment and attachment points for defects and damage.
- Ensure any equipment that needs to be out of service or isolated before accessing height safety equipment is done so.
- Ensure weather conditions are suitable for usage of the height safety equipment.

USAGE INFORMATION

Users should assure themselves immediately before and after use that the systems is in good order and condition and has been inspected, serviced where required and maintained in accordance with the manufacturer's instructions (see maintenance section of this manual).

Users should ensure that all the equipment is in good condition and working order before attempting to use the system. In particular clothing becoming caught up in SafeLink™ Shuttle preventing proper use of system.

If the user is carrying tools they must be secured to ensure they do not obstruct the users' movement along the system.

EQUIPMENT COMBINATION

For Lifeline system users must connect to the system using only SafeLink™ Shuttle and originally supplied Karabiner only. Substitution of originally supplied equipment may impede the use of the equipment. Users should consult a SafetyLink™ authorised personal if they have any questions in regard to combining equipment and suitability.

SHARP EDGES

If the possibility of a fall exists near a sharp edge which could result in weakening on a lanyard or anchorage line, protective covering should be placed over the sharp edge to diminish the damage during a fall.

LATERAL SWING (THE PENDULUM EFFECT)

Anchorage: This situation occurs where there is a lateral offset between the line from the anchorage point to the operator and the line or direction of potential fall, in the event of a fall the operator may suffer hazardous lateral swing. (see below illustrations). To eliminate the pendulum attention needs to be made to the positioning of single anchors, or the use of diversion anchors.

USE OF SAFETYLINK SYSTEM

LIFELINE

This hazardous situation can arise where a user's SafeLink™ Shuttle is near an intermediate anchor and the user falls. The shuttle will attempt to slide towards the centre span of the intermediates which can perpetuate a form of the pendulum affect.

This can become hazardous if there is a chance of colliding with a fixed object or when it greatly extends the fall distance. When a SafetyLink™ system is installed these possibilities need to be taken into account and the system designed to avoid the possibility of a hazardous lateral swing. If a user has any concerns in regard to lateral swing please contact a SafetyLink™ authorised personal.

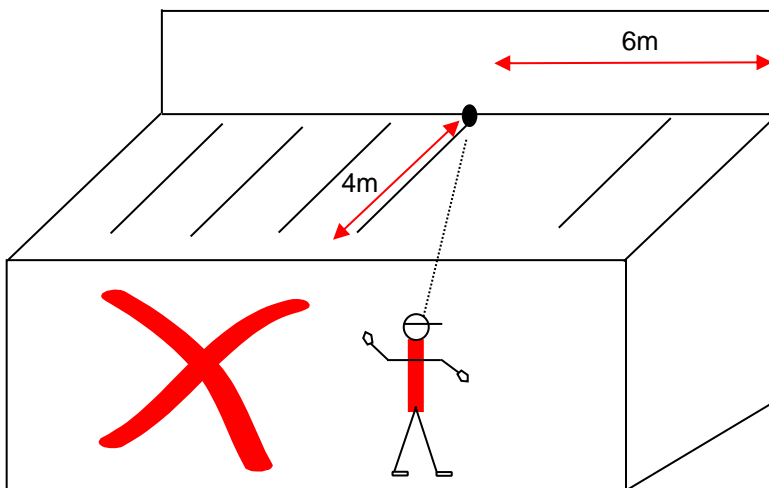
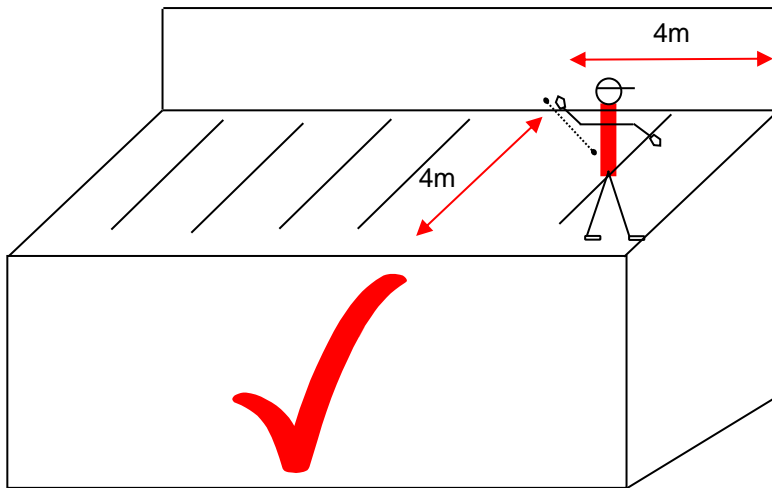

FALL-ARREST AND FALL RESTRAINT

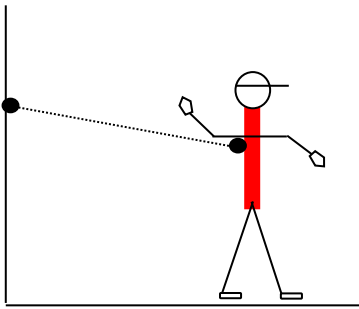

Total restraint-fall not possible

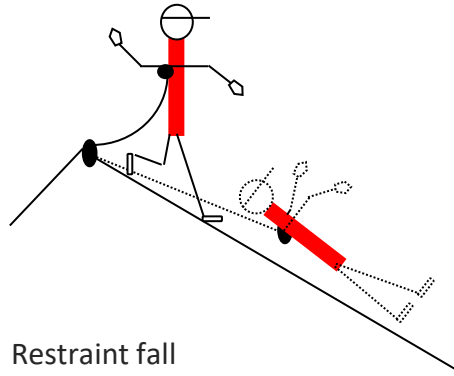

Restraint fall

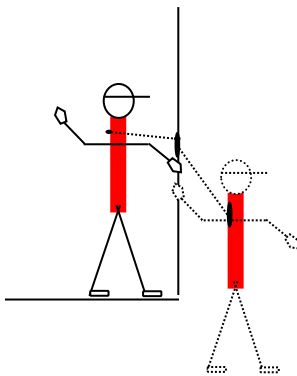

Limited free fall:
free fall distance less than 600 mm

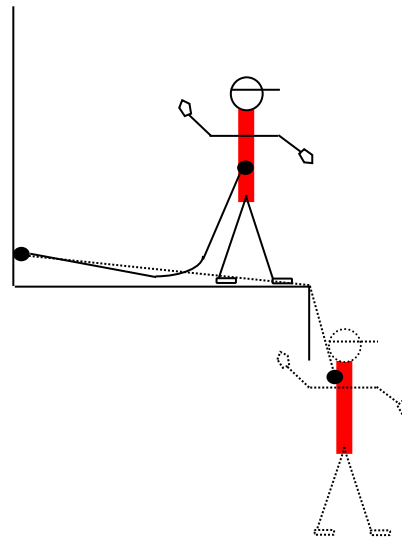

Free fall:
freefall distance greater than 600 mm

USE OF SAFETYLINK SYSTEM

OBJECTS FALLING FROM HEIGHTS

SafetyLink Systems safeguard people from falling from heights but do not prevent objects falling from heights. Additional controls need to be implemented to prevent injury from objects falling from heights.

ELECTRICAL HAZARDS

Major risks are associated with working in close proximity to overhead electrical powerlines. Specific control measures need to be followed in accordance with your states legislation, regulation and codes of practices.

USER COMPETENCY

All users of SafetyLink system must be fully trained and competent in the correct use of this product prior to being allowed to use the system.

They should have a full understanding of all Manufacturer's instructions on all equipment used on this system.

It is the responsibility of the user and purchaser of this equipment to ensure all people accessing the equipment are fully trained.

Training should be repeated periodically.

NUMBER OF USERS

See system information and labelling for Maximum users.

SYSTEM INFORMATION PLATES LABELS AND SIGNS

System information plate must be displayed on each regular entry point. The information plate will contain the following information:

- Manufacturer's and installer's name and installation date.
- System number.
- Servicing requirements and instructions, together with servicing intervals.

Example:

WARNING		ACCESS POINT		Australia 1300 789 545 International +61 249 641068 www.safetylink.com	
THIS SYSTEM MUST:					
<ul style="list-style-type: none">• BE USED ONLY BY COMPETENT PERSONS.• BE USED BY PERSONS WITH RELEVANT AUTHORISATION ONLY.• HAVE ALL SAFETY PROCEDURES COMPLIED WITH AS STATED IN THE CURRENT CODES OF PRACTICE FOR WORKING AT HEIGHTS.• BE USED WITH A FULL BODY HARNESS WITH ENERGY ABSORBER COMPLYING WITH APPROPRIATE LEGISLATION, REGULATIONS AND STANDARDS.• BE CLOSED IMMEDIATELY IN THE EVENT OF A FALL, DAMAGE OR EXPOSURE TO CHEMICALS. REOPEN UPON REPAIR & RE-CERTIFICATION.• BE INSPECTED EVERY 12 MONTHS <input type="checkbox"/> 6 MONTHS <input type="checkbox"/>					
month/	20	year	month/	20	year
month/	20	year	month/	20	year
month/	20	year	month/	20	year
month/	20	year	month/	20	year
month/	20	year	month/	20	year
ANCHOR POINTS - QTY					
FALL ARREST <input type="text"/> ABSEILING <input type="text"/>					
LOAD RATING _____ kN					
NO. OF PERSONS PER ANCHOR _____					
LIFELINE - QTY					
NO. OF PERSONS PER LINE _____ PER SPAN _____					
OTHER					
LOAD RATING _____ kN					
NO. OF PERSONS PER ANCHOR _____					
INSTALLER/CERTIFIER: _____					
SYSTEM IDENTIFICATION NO: _____					
INSTALLED/CERTIFIED DATE: _____					
DUE SERVICE DATE: _____					

SAFETYLINK LADDER STABILISERS

Made from marine grade aluminium the LadderLink is designed to support a ladder, stopping sideways movement and therefore holding the ladder in place safely. In addition the LadderLink has securing points to tie off the ladder providing a safe access point.

- ⚠ Adjusting the pitch of the LadderLink to suit steeper roof pitches maybe required. This must be completed with an appropriate sheet metal bending machine only. LadderLink's are made from high tensile aluminium, the bender must be set on a high radius to prevent cracking. Failure to do so may result in a damaged and unsafe ladder bracket.
- ⚠ Always use a leash in conjunction with securing points on the LadderLink to secure your ladder once fitted to a ladder bracket.
- ⚠ Protective coating must not be removed.

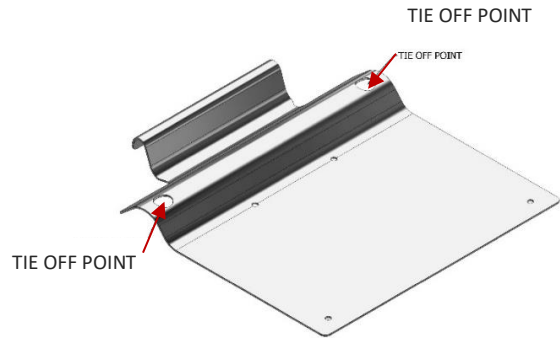

INSTALLATION FOR METAL ROOFS – UNDER ROOF SHEETING

1. To install the LadderLink simply remove existing hex head roofing screws along the bottom edge of the roof sheeting at the desired location.
2. Slide the ladder bracket under the roof sheeting between the sheeting and batten as shown in the diagram below.
3. Position the ladder bracket so the rolled section is centred over the gutters front edge.
4. Once the ladder bracket is in the desired location, re-install the hex head roofing screws through the original holes, through the ladder bracket and into the roof batten below.
5. Ensure that a minimum of three (3) x 12g 65mm roofing screws anchor the ladder bracket to the structure (recommended to pilot drill holes).

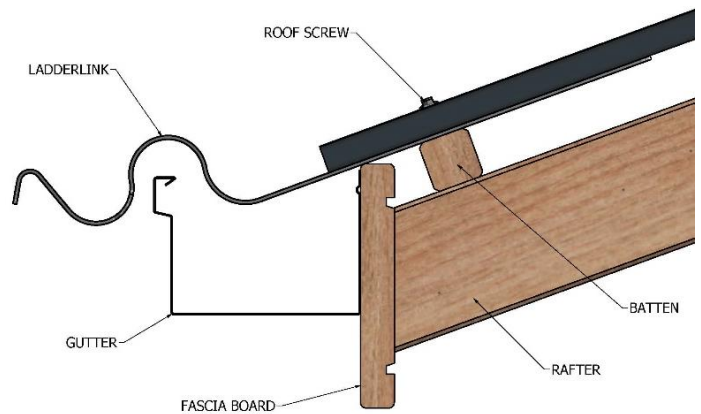

INSTALLATION FOR METAL ROOFS – ON TOP OF ROOF SHEETING

1. To install the LadderLink simply remove existing hex head roofing screws along the bottom edge of the roof sheeting at the desired location.
2. Place the ladder bracket on top of the roof sheeting as shown in the diagram below.
3. Position the ladder bracket so the rolled section is centred over the gutters front edge.
4. Once the ladder bracket is in the desired location, re-install the hex head roofing screws through the ladder bracket, ensure the screws go through the roof sheeting and into the roof batten below.
5. Ensure that a minimum of three (3) x 12g 65mm roofing screws anchor the ladder bracket to the structure (recommended to pilot drill holes).
6. Install an additional two (2) x 8mm Rivets at the top corners 50mm down from the top edge, see below diagram. This must be completed to prevent rocking of the ladder bracket.

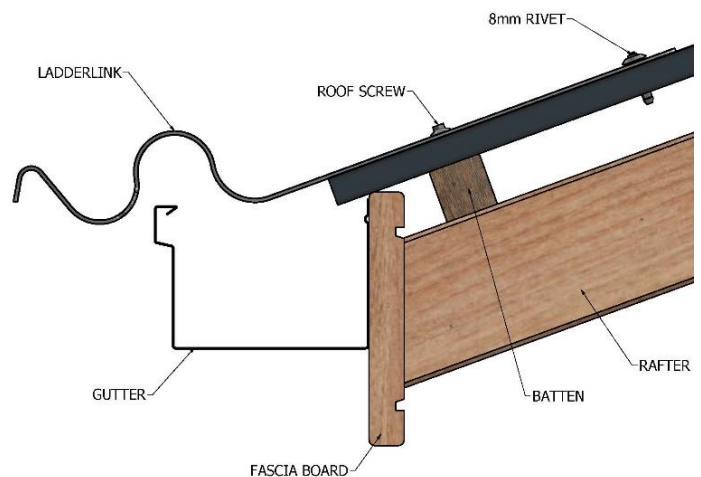

SAFETYLINK LADDER STABILISERS

INSTALLATION FOR TILED ROOFS

1. To install the LadderLink simply remove roof tiles at the desired location.
2. Place the ladder bracket onto the batten, ensure a rafter is centred below the ladder bracket.
3. Adjust the ladder bracket so the rolled section is centred over the gutters front edge, as shown in the diagram below.
4. Once the ladder bracket is in the desired location, install three (3) x 65mm 12g hex head roofing screws through the ladder bracket and into the roof batten below (recommended to pilot drill holes).
5. Cut a short tile batten to fit as a spacer under the ladder bracket between the rafter and ladderlink.
6. Using one (1) x 100mm 14g hex head roofing screw, anchor the ladder bracket to the rafter below (recommended to pilot drill holes). This should be centred and installed 50mm down from the top edge of the ladder bracket (see diagram).
7. Ensure that a minimum of three (3) x 12g 65mm and one (1) x 14g x 100mm roofing screws anchor the ladder bracket to the structure.
8. Ensure the timber structure is secured in accordance with current Building Codes.

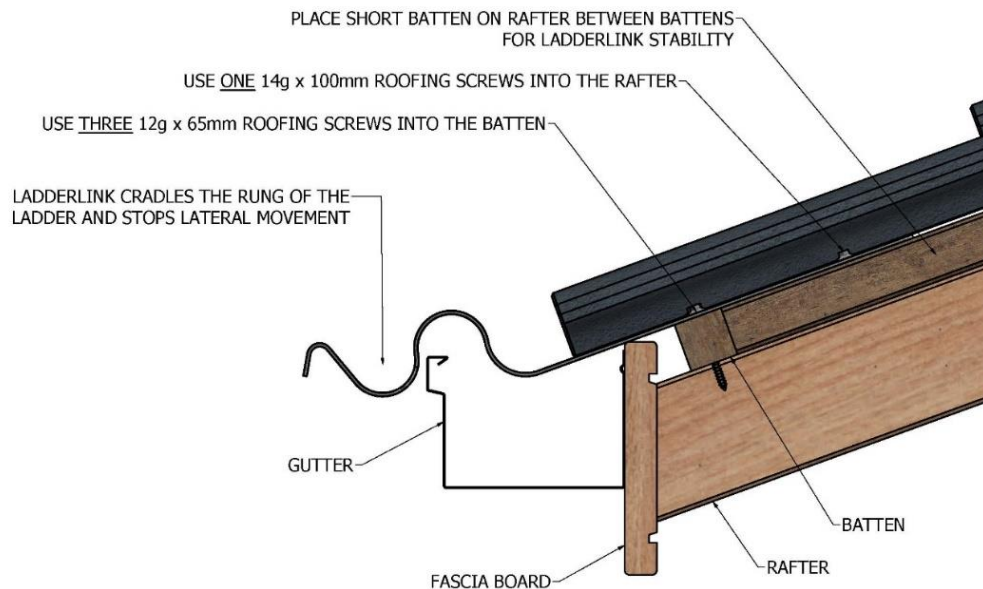

WALL MOUNTED LADDERLINK

- To install the LadderLink place in the desired location, ensuring there is suitable structure to support the brackets use.
- Once the ladder bracket is in the desired location, drill securing holes in both the LadderLink and mounting structure to suit method of attachment (see recommended fixing options below).
- Ensure that a minimum of four (4) appropriate fixings are used to anchor the ladder bracket to the structure.
- Fixings should be evenly spaced ideally 50mm in from the LadderLink edges to create a secure installation (see below).

FIXING TO TIMBER WALL/PARAPET

1. Drill and install 4 (four) 14g x 75mm roofing screws (recommended to pilot drill holes).
2. Ensure the timber structure is secured in accordance with current Building Codes.

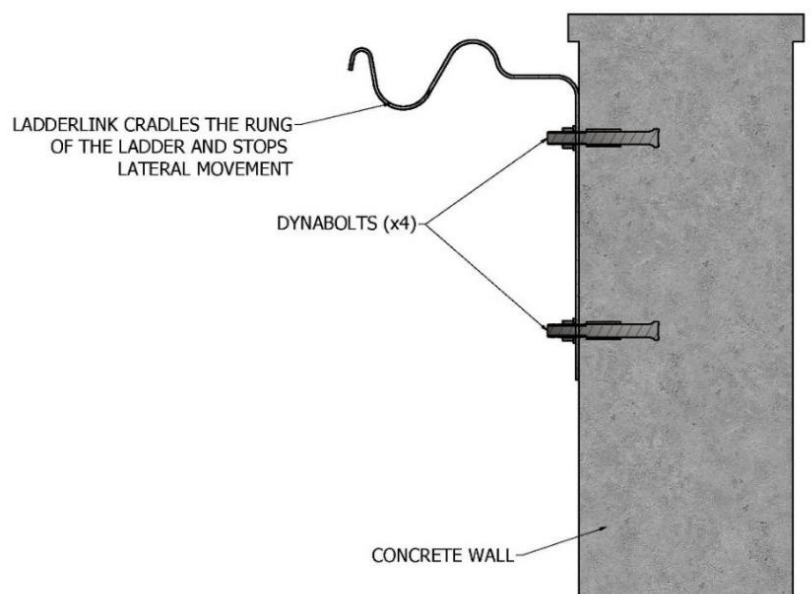

FIXING TO CONCRETE WALL/PARAPET

1. Drill and install 4 (four) M10 Dyna bolts or equivalent chemical anchor.
2. Ensure anchoring bolts are a minimum of 150mm from concrete wall edges.

SAFETYLINK ANCHORAGES – PROGRESSING ALONG SYSTEM – FIGURE 3

⚠ A FALL RESCUE PLAN SHOULD BE DEVELOPED PRIOR TO USING SAFETYLINK EQUIPMENT.

Figure 3 – Progressing along the line to point A.

THIS IS A GUIDE ONLY

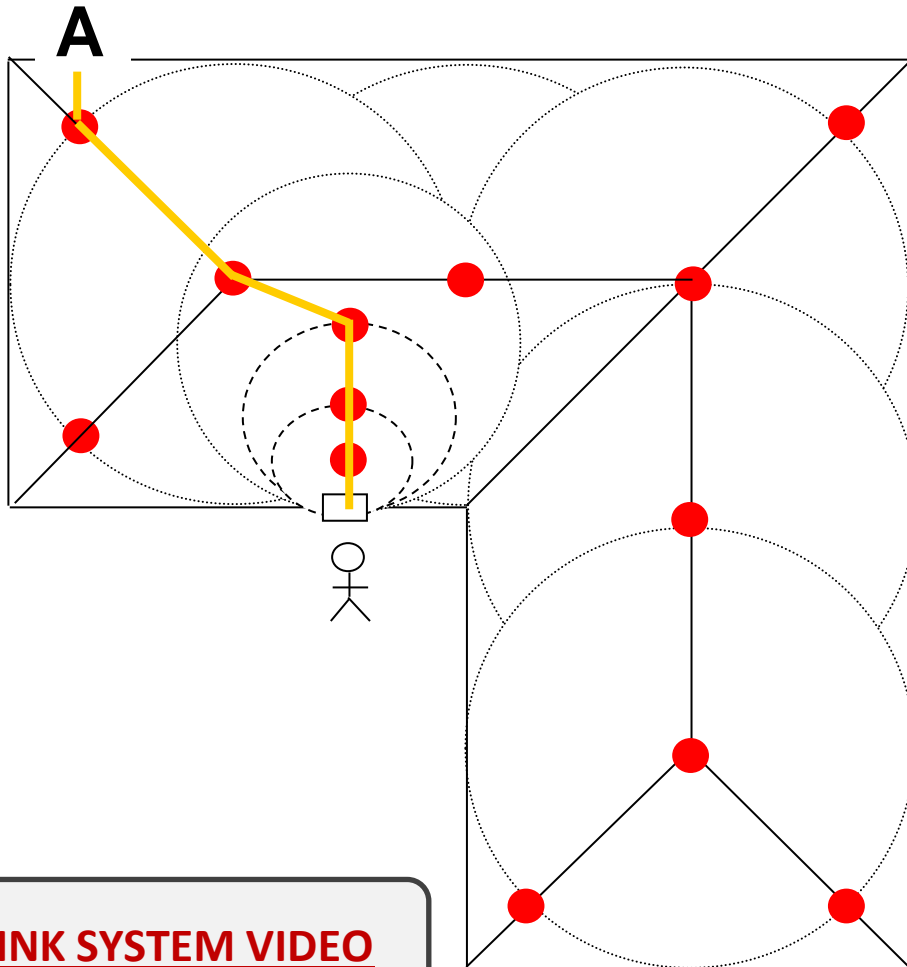

FROGLINK SYSTEM VIDEO

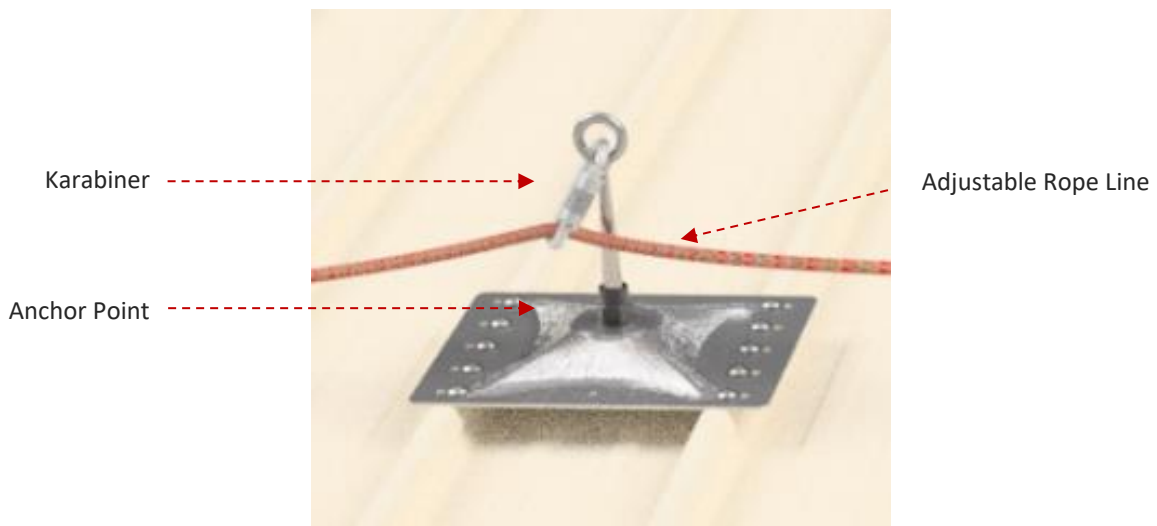

SAFETYLINK ANCHORAGES

PROGRESSING ALONG THE ANCHOR SYSTEM

THE FOLLOWING IS AN **EXAMPLE** OF PROGRESSING ALONG THE LINE TO **POINT A** IN [FIGURE 3](#).

1. Consult site safety plan and plan your path accordingly. Do not attempt to bypass any consecutive anchors.
2. Find the safest access point around the perimeter of the building.
3. Check the access sign has a current certification.
4. Place a ladder on the fixed LadderLink and tie the ladder to LadderLink.
5. Inspect your full body harness gear and equipment as per manufacturers' instructions and fit to body as per manufacturers instruction fitting.
6. Connect Shock absorbing lanyard to metal D ring on the back of the harness via a karabiner.
7. Connect adjustable rope line to shock absorbing lanyard using a karabiner.
8. Connect the adjustable rope line to the first anchor. Do not attempt to step onto the roof unless this connection has been made and checked and any slack taken out of the line.
9. Dismount the ladder and connect the karabiner to second anchor.
10. Run adjustable rope line through karabiner and anchor (making sure to lock karabiner).
11. Continue connecting through anchors to reach desired location using same method as shown on figure 3 (figure 3 on previous page).

DISCONNECTING FROM THE ANCHOR SYSTEM

Complete job and work your way back to ladder disconnecting karabiners while back tracking back to ladder.

⚠ DURING INSTALLATION YOU MUST BE SAFE AT ALL TIMES.

Where a risk of a fall exists on entering or exiting the SafetyLink™ system additional fall prevention measures must exist. Where additional fall prevention exists on entry and exit the user must ensure:

1. Attachment is correctly made to the life line system before detaching from the additional fall prevention system.
2. DO NOT detach from the lifeline system unless correct attachment is made to the additional fall prevention system.



LIFELINE SYSTEM – HORIZONTAL SHUTTLES

⚠ A FALL RESCUE PLAN SHOULD BE DEVELOPED PRIOR TO USING SAFETYLINK EQUIPMENT.

CONNECTING TO THE LIFELINE (USING SAFELINK™ SHUTTLE)

1. Remove Karabiner supplied with SafeLink™ Shuttle by rotating karabiner 90° from the main frame, unscrewing the karabiner and removing from the main frame and locking gate.
2. Slide the locking gate of the SafeLink™ down and place the SafeLink™ onto the line facing the main frame of the unit downwards.
3. Slide the locking unit back up into original position and insert Karabiner through the main frame and locking gate. Screw Karabiner shut. This secures the SafeLink™ to the line.
4. Ensure Karabiner is attached to personal fall arrest equipment.



CONNECTING TO THE LIFELINE (USING FROGLINE SHUTTLE)

1. Remove the Karabiner from the FrogLine Shuttle. The supplied Karabiner is a SafetyLink steel trilock and needs three distinct movements to be removed from the shuttle (Slide gate up, twist gate, depress gate).
2. Slide the inner component of the FrogLine shuttle to the right or left of the shuttle body. This will put the two shuttle karabiner connecting holes adjacent to each other and widen the mouth of the shuttle. The shuttle is now in the open position and can be placed face down onto the lifeline cable.
3. To lock the shuttle onto the cable, push the inner component from its position to the right or left back across the shuttle body. This will re-align the karabiner connection holes and narrow the mouth of the shuttle.
4. Insert the SafetyLink Karabiner through both connecting holes. This locks the shuttle body and inner component of the shuttle together and ensures the shuttle remains in the closed position. Check that the Karabiner has locked correctly. The Shuttle is now secured to the life line system.
5. It is a requirement when connecting a lanyard between the users harness and FrogLine shuttle/lifeline system that a personal tear web energy absorber be used. This tear web energy absorber needs to be at the harness end of the lanyard to ensure maximum energy absorption.



- ⚠ MAKE SURE YOU ARE SAFE AT ALL TIMES WHILST ATTACHING OR DETACHING FROM THE FROGLINE LIFELINE SYSTEM.**
- ⚠ A FALL RESCUE PLAN SHOULD BE DEVELOPED PRIOR TO USING SAFETYLINK EQUIPMENT.**
- ⚠ ENSURE YOU USE THE SAFETYLINK KARABINER SUPPLIED ONLY.**



FROGLINE LIFELINE SYSTEM VIDEO

PROGRESSING ALONG THE LIFELINE

1. Always Progress the system manually. Do not progress in any vehicle or motioning device.
2. When progressing towards a corner, to ensure the Shuttle continues on a smooth path avoid cutting the corner sharply.
3. Do not place any tools or equipment onto the line.

DISCONNECTING FROM THE CLASSIC SAFETYLINK LIFELINE

1. If you are attaching to an alternative fall arrest system ensure you are attached to that system before disconnecting from the Lifeline System.
2. Unlock Karabiner and detach it from main frame and locking gate of the SafeLink™ Shuttle.
3. Slide locking gate down and lift main frame off line.
4. Slide locking unit back up into original position and insert Karabiner through main frame and locking gate to store.



DISCONNECTING FROM THE FROGLINE LIFELINE

1. If you are attaching to an alternative fall arrest system ensure you are attached to that system before disconnecting from the FrogLine System.
2. Unlock Karabiner and detach it from the FrogLine Shuttle.
3. Slide the inner component of the FrogLine shuttle to the right or left of the shuttle body. This will put the two shuttle karabiner connecting holes adjacent to each other and widen the mouth of the shuttle. The shuttle is now in the open position and can be removed from the lifeline cable.
4. Slide inner component of the Shuttle into original position and insert Karabiner through the two connecting holes to store.



⚠ DURING INSTALLATION YOU MUST BE SAFE AT ALL TIMES.

Where a risk of a fall exists on entering or exiting the life line system additional fall prevention measures must exist. Where additional fall prevention exists on entry and exit the user must ensure:

1. Attachment is correctly made to the life line system before detaching from the additional fall prevention system.
2. DO NOT detach from the lifeline system unless correct attachment is made to the additional fall prevention system.

PERSONAL PROTECTIVE EQUIPMENT

Users should ensure that all the equipment is in good condition and working order before attempting to use the system. In particular clothing becoming caught up in equipment preventing proper use of system.

Users of SafetyLink Systems must wear a full body harness with a personal energy absorber, rope line adjusters and karabiners to be attached to the fall arrest systems.

Manufacturer's instructions must be followed to fit the harness and all warnings, inspections and instructions of the manufacturer must be followed.

Should you have any questions about the suitability of your personal protective equipment please contact SafetyLink Pty Ltd on 1300 789 545 or +61 2 49641 068.

LIFELINE SYSTEM – OVERHEAD SHUTTLE

CONNECTING TO THE LIFE LINE SYSTEM

1. Remove the karabiner from the overhead shuttle. The supplied Karabiner is a SafetyLink steel trilock and needs three distinct movements to be removed from the shuttle (slide gate up, twist gate, depress gate).
2. Twist the shuttle gate to the right or left of the shuttle body. This will put the shuttle gate off to one side widening the mouth of the shuttle. The shuttle is now in the open position and can be placed onto the lifeline cable.
3. To lock the shuttle onto the cable, twist the shuttle gate back to the centre position on the shuttle body. This will re-align the karabiner connection holes and narrow the mouth of the shuttle. Insert the karabiner through both connecting holes. This will lock the shuttle body and shuttle gate together and ensures the shuttle remains in the closed position. Check that the karabiner has locked correctly. The shuttle is now secured to the life line system.
4. It is a requirement when connecting a lanyard between the users harness and shuttle/lifeline system that a personal tear web energy absorber be used. This tear web energy absorber needs to be at the harness end of the lanyard to ensure maximum energy absorption.

⚠ MAKE SURE YOU ARE SAFE AT ALL TIMES WHILST ATTACHING OR DETACHING FROM THE FROGLINE SYSTEM.

⚠ A FALL RESCUE PLAN SHOULD BE DEVELOPED PRIOR TO USING SAFETYLINK EQUIPMENT.

⚠ ENSURE YOU USE THE SAFETYLINK KARABINER SUPPLIED ONLY.

PROGRESSING ALONG THE LIFE LINE SYSTEM

1. Always progress the system manually. Do not progress in any vehicle or motioning device.
2. When progressing towards a corner, to ensure the Shuttle continues on a smooth path avoid cutting the corner sharply.
3. Do not place any tools or equipment onto the life line system.

DISCONNECTING FROM THE LIFE LINE SYSTEM

1. If you are attaching to an alternative fall arrest system ensure you are attached to that system before disconnecting from the FrogLine System.
2. Unlock Karabiner and detach it from the FrogLine Shuttle.
3. Twist the shuttle gate to the left or right of the shuttle body. This will put the two shuttle karabiner connecting holes adjacent to each other and widen the mouth of the shuttle. The shuttle is now in the open position and can be removed from the lifeline cable.
4. Twist shuttle gate back to the centre of the shuttle into its original position and insert Karabiner through the two connecting holes to store.



⚠ REMEMBER YOU MUST BE SAFE AT ALL TIMES.

Where a risk of a fall exists on entering or exiting the life line system additional fall prevention measures must exist. Where additional fall prevention exists on entry and exit the user must ensure:

1. Attachment is correctly made to the life line system before detaching from the additional fall prevention system.
2. DO NOT detach from the lifeline system unless correct attachment is made to the additional fall prevention system.

SAFETYLINK PERMANENT LADDER SYSTEM

LADDERS WITH VERTICAL LIFELINES

⚠ A FALL RESCUE PLAN SHOULD BE DEVELOPED PRIOR TO USING SAFETYLINK EQUIPMENT.

- Ladder should be only used for access. If it is intended to work from a ladder, the work should be light duty and short duration.
- One person is to be on the ladder at any one time (except in emergency situations).
- **Three points of contact with the ladder should be maintained on the ladder at all times. For example, two feet one hand, one foot and two hands, two feet and the frontal D ring on a fall arrest harness attached to the fall arrest line.**
- When going up or down a ladder you should always face the ladder.

CONNECTING TO THE LINE

(USING VERTICAL SHUTTLE SUPPLIED WITH SYSTEM)

1. Vertical shuttle to be used with original karabiner supplied.
2. Slide up the locking gate as indicated and attach the shuttle to the line. Release locking gate to secure to line.
3. Ensure Karabiner is attached to personal fall arrest equipment.

PROGRESSING ALONG THE LINE

1. Always Progress the system manually. Do not progress in any vehicle or motioning device.
2. Do not place any tools or equipment onto the line.

DISCONNECTING FROM THE LINE

1. If you are attaching to an alternative fall arrest system, ensure you are attached to that system before disconnecting from the Vertical Lifeline.
2. Slide up the locking gate as indicated and detach the shuttle to the line.



⚠ DURING INSTALLATION YOU MUST BE SAFE AT ALL TIMES.

Where a risk of a fall exists on entering or exiting the lifeline system additional fall prevention measures must exist. Where additional fall prevention exists on entry and exit the user must ensure:

1. Attachment is correctly made to the life line system before detaching from the additional fall prevention system.
2. DO NOT detach from the lifeline system unless correct attachment is made to the additional fall prevention system.

MAINTENANCE

SAFETYLINK LADDER STABILISERS

ALL LADDERLINKS MUST BE INSPECTED EVERY 12 MONTHS, INSPECTIONS NEED TO BE CARRIED OUT BY A COMPETENT HEIGHT SAFETY INSTALLER.

Procedures to be followed at inspection time:

- Visually inspect ladder support brackets for any signs of deterioration or the protective coating being removed. (Note: LadderLink is made from marine grade aluminium and therefore should not corrode).
- Ensure LadderLink is firmly secured to the structure as per SafetyLink Installation Handbook (refer Installing LadderLink).

SAFETYLINK PERMANENT LADDER SYSTEMS

- Visually inspect the components of the Permanent Ladder for corrosion. Superficial surface marking is permitted while deeper corrosion or pitting would require attention.
- Inspect stiles and rungs for missing worn damaged twisted or warping of any kind.
- Permanent Ladder should be checked prior to every use and maintained in good condition.
- Under no circumstances shall any temporary repairs be made to any Permanent Ladder.
- Visually inspect the fixing component of the Permanent Ladder System.
- Visually inspect the parent structure for modifications or deterioration which might lead to loss of strength.
- Check for the presence of contaminants or exposure to a corrosive or extreme environment which could significantly reduce the working load of the Permanent Ladder System.

Where a Vertical Lifeline is present on the system:

- Check the condition of line tensioners and termination.
- Check for any evidence of wear, cuts, looseness, extension, interstrand wear, corrosion, stiffness, brittleness or fraying of the steel cable.
- Run the Vertical Shuttle along the length of the line to verify its correct function.



MAINTENANCE

SAFETYLINK ANCHORAGES

(In accordance with AS/NZS 1891.4:2009 clause 9.1)

ALL ANCHORAGES MUST BE INSPECTED EVERY 12 MONTHS, inspections need to be carried out by a competent height safety installer. The system also needs to be re-certified by an Engineer where the systems original date of installation exceeds 10 years, and every subsequent 5 years after that.

Procedures to be followed at inspection time:

- Visually inspect anchors for signs of deterioration.
- The FrogLink/TileLink anchor point has two energy absorbing regions and two stabilising joints which hold the eyelet in place during use. If these energy absorbing regions are expanded this will indicate the anchor point has arrested a fall. Similarly, if the two stabilising joints have been broken this would also indicate the FrogLink/TileLink has arrested a fall and should be replaced.
- The eyebolt should remain straight, a bent eyebolt will indicate that the anchor point has arrested a fall (*The design features of the eyebolt includes the ability to bend like a fishing pole starting from the top and working its way to the bottom, enabling it to use up energy as the eyebolt bends whilst lessening the force on the person falling and the attachment point*).
- Visually inspect the components of the anchor for corrosion, superficial surface marking is permitted while deeper corrosion or pitting would require attention.
- Manually (by hand) check the eyebolt for rigidity and tightness, if the eyebolt can turn in the anticlockwise direction it will require attention.
- Visually inspect the rubber hat washer and waterproofing components to ensure it has remained sealed.
- Visually inspect the attachment component of the anchorage where practically possible.
- Visually inspect the parent structure for modifications or deterioration which might lead to loss of anchorage strength.
- To comply with Australian Standards, each Concrete Anchor must be tested after installation and at every recertification inspection. Ensure you wait the recommended curing time as specified by the chemical anchor instructions. The pull test can be done using a 16mm threaded eyebolt. Test consists of ultimate pull out force proof loading to 50% of design purpose of anchorage.

MAINTENANCE

SAFETYLINK LIFELINE SYSTEMS

ALL LIFELINE SYSTEMS MUST BE INSPECTED EVERY 12 MONTHS, inspections need to be carried out by a competent height safety installer. The system also needs to be re-certified by a height safety equipment inspector where the systems original date of installation exceeds 10 years, and every subsequent 5 years after that.

Procedures to be followed at inspection time:

- Visually inspect anchors for signs of deterioration.
- The FrogLine End, Intermediate and Corner anchor points have energy absorbing regions and stabilising joins. If these energy absorbing regions are expanded this will indicate the anchor point has arrested a fall and should be replaced. Similarly, if the stabilising joins have been broken this would also indicate the anchor point has arrested a fall and should be replaced. *(The design features of the FrogLine's curved profile provides the initial shock absorbing capabilities in the event of a fall. Further extension is provided in the serpentine shapes which progressively dissipate and absorb energy whilst retaining their strength. This lessens the force on the person falling and the structure the anchor is attached to).*
- The End Anchor Tapered Bolt and Intermediate T Bolts should remain straight, a bent End Anchor Tapered Bolt or Intermediate T Bolt will indicate that the Static line has arrested a fall *(The design features of the End Anchor Tapered Bolt and Intermediate T Bolts includes the ability to bend like a fishing pole starting from the top and working its way to the bottom, enabling it to use up energy as the eyebolt bends whilst lessening the force on the person falling and the attachment point).*
- Visually inspect the components of the anchor for corrosion, superficial surface marking is permitted while deeper corrosion or pitting would require attention.
- Manually (by hand) check the 16mm Bolts securing the FrogLine Base to the Base Plate, Washer and 16mm Nut for rigidity and tightness. If the Bolt can turn in the anticlockwise direction it will require attention.
- Manually (by hand) check the End Anchor Tapered Bolt and Intermediate T Bolt for rigidity and tightness, if the End Anchor Tapered Bolt and Intermediate T Bolt can turn in the anticlockwise direction it will require attention.
- Visually inspect the attachment component of the anchorage where practically possible.
- Visually inspect the parent structure for modifications or deterioration which might lead to loss of anchorage strength.
- Check the full length of the stainless steel cable for any evidence of wear, cuts, looseness, extension, inter-strand wear, corrosion, stiffness, brittleness or fraying.
- Check the integrity of cable terminations and that lifeline tensioners are correctly adjusted (80kg/0.8kN/800N) and lock nuts are tensioned correctly.
- Check for the presence of contaminants or exposure to corrosive or extreme environment signs may include discoloration, crystallising or oxidation. These could significantly reduce the safe working load of the Lifeline.
- Run the FrogLine Shuttle along the full length of the life line to verify its correct function.
- For Concrete Installation Only: To comply with Australian Standards, each ConcreteLink must be tested after installation and at every recertification inspection. Ensure you wait the recommended curing time as specified by the chemical anchor instructions. The pull test can be done using a 16mm threaded eyebolt. Test consists of ultimate pull out force proof loading to 50% of design purpose of anchorage.

IN ADDITION TO SAFETYLINK PTY LTD EQUIPMENT, ALL ANCILLARY EQUIPMENT MUST BE INSPECTED IN ACCORDANCE WITH APPLICABLE REGULATORY REQUIREMENTS AND THE MANUFACTURER'S INSTRUCTIONS.



FOR MAINTENANCE ADVICE AND SERVICES PLEASE CONTACT SAFETYLINK ON +61 249 641068 OR 1300 789545 FOR YOUR NEAREST SAFETYLINK INSPECTION SERVICE CENTRE OR EMAIL: info@safetylink.com

ANCHORS AND LADDER STABILISERS INSTALLATION AND RECERTIFICATION CHECKLIST

This checklist is to help you compile information about the SafetyLink Anchor and Ladder Stabiliser Systems to ensure it is installed and maintained as per SafetyLink Installation Guides.

All anchorages and swaged/swageless/crimped components must be inspected every 12 months, inspections need to be carried out by a competent height safety equipment inspector who has been trained in the safe use and maintenance of this system. The system will require re-certification by height safety assessor "suitable qualified engineer or competent height safety installer as defined in AS/NZS 1891.4:2009 clause 1.4 DEFINITIONS" where the systems original date of installation exceeds 10 years, and every subsequent 5 years after that.

All anchors must be numbered and tagged as compliant at installation and re-tagged on re-certification. Tag number codes are to be used in conjunction with a site plan.

NOTE: THIS CHECKLIST IS TO BE USED IN CONJUNCTION WITH A SITE LAYOUT PLAN AND SAFETYLINK INSTALLATION GUIDES AND USER MANUALS.





Date checklist completed: ____/____/____	
Date checklist to be redone (annually or when there is a change or addition to the system): ____/____/____	
Name(s) of person(s) who completed checklist:	
Position:	Company:

OVERALL CHECK	ACTION TAKEN IF NO
Review site layout plan, have the anchors been correctly positioned? <input type="checkbox"/> Yes <input type="checkbox"/> No	
Have all anchors and components been tagged and noted on site plan? <input type="checkbox"/> Yes <input type="checkbox"/> No	
Have all anchors been installed as per SafetyLink Installation Guides? <input type="checkbox"/> Yes <input type="checkbox"/> No	



INDIVIDUAL ANCHOR AND COMPONENT CHECK	Insert number code for NON COMPLYING anchors or components (per site plan).	ACTION TAKEN to rectify non complying anchors.
Visually inspect all Ladder Support Brackets for any signs of deterioration or the protective coating being removed.		
Ensure Ladder Support Bracket is firmly secured to the structure as per SafetyLink Installation Handbook.		
Visually inspect the parent structure for modifications or deterioration which might lead to loss of anchorage strength.		
Visually inspect the Anchor for corrosion, superficial surface marking is permitted while deeper corrosion or pitting would require attention.		
Visually inspect the components of the anchor for corrosion, superficial surface marking is permitted while deeper corrosion or pitting would require attention.		
Visually inspect the attachment component of the anchorage where practically possible.		
Check all Locking Hex Nuts on anchors are tightly secured.		
The Eyebolt should remain straight, a bent eyebolt will indicate that the anchor point has arrested a fall and should be taken out of service.		
Manually check the Eyebolt for rigidity and tightness; if the eyebolt can turn in the anticlockwise direction it will require attention.		
Installed onto Roof Sheet laps/joins. Check that ten (10) bulbtite rivets have been used to install the SurfaceLink Plate. Check the rivets have been installed and secured correctly.		
Installed onto Roof Sheet screwline. Check one roofing screw is installed in centre hole of plate with 4 Rivets on each side.		



ANCHORS AND LADDER STABILISERS INSTALLATION AND RECERTIFICATION CHECKLIST

INDIVIDUAL ANCHOR AND COMPONENT CHECK	Insert number code for NON COMPLYING anchors or components (per site plan).	ACTION TAKEN to rectify non complying anchors.
<p>Check that the correct amount of Rivets have been used on surface mounted anchors/lifeline. Check the rivets have been installed and secured correctly.</p>  <p>Ensure mandrel is seen just below the sealing mound. The sealing mound needs to be connected to the top of the mandrel to ensure waterproofing is maintained. Additional waterproofing measures may be required. Pictures show a correctly deployed rivet. Ensure green seal is in place and functional between rivet top and anchor surface to ensure waterproofing is maintained.</p> 		
<p>The FrogLink/TileLink anchor point has two energy absorbing regions and two stabilising joints which hold the eyelet in place during use. If these energy absorbing regions are expanded this will indicate the anchor point has arrested a fall. Similarly, if the two stabilising joints have been broken this would also indicate the FrogLink/TileLink has arrested a fall and should be replaced.</p> 		
<p>Once the TileLink has been inspected ensure you reapply silicone and replace the tile.</p>		
<p>Drilled in anchorages such as friction or glued-in anchorages must be tested after installation and at every recertification inspection. Ensure you wait the recommended curing time as specified by the chemical anchor instructions. The pull test can be done using a 16mm threaded eyebolt. Test consists of ultimate pull out force proof loading to 50% of design purpose of anchorage.</p> 		

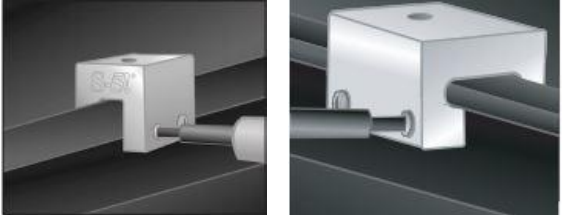
ANCHORS AND LADDER STABILISERS INSTALLATION AND RECERTIFICATION CHECKLIST

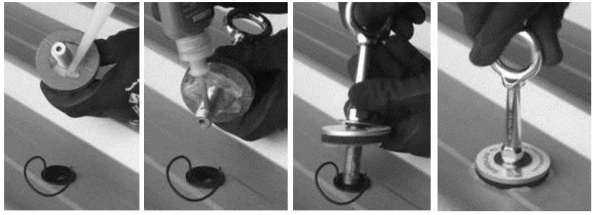
INDIVIDUAL ANCHOR AND COMPONENT CHECK	Insert number code for NON COMPLYING anchors or components (per site plan).	ACTION TAKEN to rectify non complying anchors.
<p>S5_Z Clamps should be checked to ensure the setscrews are tensioned to 160 and 180 inch pounds on 22ga steel, and 130 to 150 inch pounds on all other metals and thinner gauges of steel (see installation guides).</p> 		
<p>Ensure plate fixing bolts on the top of the S-5 Clamps are tightly secured.</p> 		
<p>Ensure Retro Washers have additional silicone applied under the washer. Visually inspect the waterproofing component to ensure it has retained a weatherproof seal.</p> 		

⚠ WARNINGS

During installation you must be safe at all times. All safety procedures must be complied with in accordance with the current legislation and regulations. Ensure safety at all times by being attached to anchor point approved safety equipment, using a scaffold or a secured ladder.

All items of equipment which are in regular use shall be subjected to periodic inspection and servicing. These regular scheduled inspections and servicing must be carried out by a competent height safety installer. (*refer to AS/NZS 1891.4:2009 if clarification required or contact us*).

The building or structure for the anchorages should be assessed by an engineer, unless it is clear to a competent height safety installer that the anchorages system is structurally adequate.

INSTALLATION MUST BE CARRIED OUT BY, OR UNDER THE SUPERVISION OF A COMPETENT HEIGHT SAFETY INSTALLER.

**If you are uncertain and need help please call +61 249 641068 or 1300 789545,
email: info@safetylink.com or visit our website www.safetylink.com**

LIFELINE AND LADDER STABILISERS INSTALLATION AND RECERTIFICATION CHECKLIST

This checklist is to help you compile information about the SafetyLink Lifeline and Ladder Stabiliser Systems to ensure it is installed and maintained as per SafetyLink Installation Guides.

All anchorages and swaged/swageless/crimped components must be inspected every 12 months, inspections need to be carried out by a competent height safety equipment inspector who has been trained in the safe use and maintenance of this system. The system will require re-certification by height safety assessor "suitable qualified engineer or competent height safety installer as defined in AS/NZS 1891.4:2009 clause 1.4 DEFINITIONS" where the systems original date of installation exceeds 10 years, and every subsequent 5 years after that.

All anchors must be numbered and tagged as compliant at installation and re-tagged on re-certification. Tag number codes are to be used in conjunction with a site plan.

NOTE: THIS CHECKLIST IS TO BE USED IN CONJUNCTION WITH A SITE LAYOUT PLAN AND SAFETYLINK INSTALLATION GUIDES AND USER MANUALS.

Date checklist completed: ____/____/____	
Date checklist to be redone (annually or when there is a change or addition to the system): ____/____/____	
Name(s) of person(s) who completed checklist:	
Position:	Company:



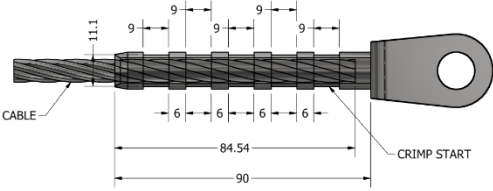

OVERALL CHECK	ACTION TAKEN IF NO
Review site layout plan, have the anchors been correctly positioned? <input type="checkbox"/> Yes <input type="checkbox"/> No	
Have all anchors and components been tagged and noted on site plan? <input type="checkbox"/> Yes <input type="checkbox"/> No	
Have all anchors been installed as per SafetyLink Installation Guides? <input type="checkbox"/> Yes <input type="checkbox"/> No	

INDIVIDUAL ANCHOR AND COMPONENT CHECK	Insert number code for NON COMPLYING anchors or components (per site plan).	ACTION TAKEN to rectify non complying anchors.
Visually inspect all Ladder Support Brackets for any signs of deterioration or the protective coating being removed.		
Ensure Ladder Support Bracket is firmly secured to the structure as per SafetyLink Installation Handbook.		
Visually inspect the parent structure for modifications or deterioration which might lead to loss of anchorage strength.		
Visually inspect Anchors for signs of deterioration.		
Check all Locking Hex Nuts on anchors are tightly secured.		
In addition to tagging all anchors ensure number Coded Tags have been fitted around swageless fittings indicating it has been installed as per manual. 		
Check the full length of the stainless-steel Cable for any evidence of wear, cuts, looseness, extension, inter-strand wear, corrosion, stiffness, brittleness or fraying.		
Check for the presence of contaminants or exposure to a corrosive or extreme environment signs may include discoloration, crystalline or oxidation. These could significantly reduce the safe working load of the Lifeline .		

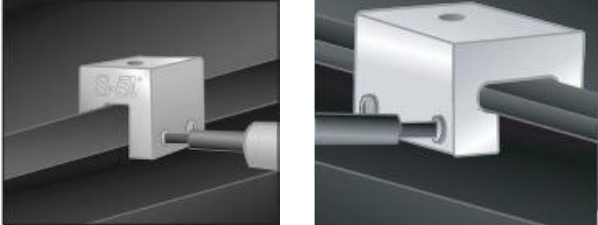

LIFELINE AND LADDER STABILISERS INSTALLATION AND RECERTIFICATION CHECKLIST

INDIVIDUAL ANCHOR AND COMPONENT CHECK	Insert number code for NON COMPLYING anchors or components (per site plan).	ACTION TAKEN to rectify non complying anchors.
<p>Lifeline: Ensure maximum distance between End, Intermediate and Corner Anchors is 10 metres.</p>		
<p>Frogline Lifeline: The end anchor and intermediates should remain in an S shape; a straight end anchor or intermediates will indicate that the end anchor and intermediates has arrested a fall and should be taken out of service.</p>		
 <p>Manually check the lifeline components for rigidity and tightness. An intermediate that can turn in anticlockwise direction will require attention.</p>		
<p>Check fall indicator tags on end, intermediate and corner anchors for signs of stretching, distortion or breakage. This will indicate the system has been loaded or a fall has been arrested on the system. The system should immediately be taken out of service.</p>		
<p>Check the lifeline cable tensioner (could be one at each end of system depending on system length) for correct tension. Tension should be 80kN, this can be checked by seeing if the tension indicator disc spins freely. WARNING do not over tension the system, this may result in End/Corner anchors being over loaded and starting to deploy there energy absorbing regions.</p>		
<p>Ensure Swageless Fittings have been installed as per installation manual and all locking nuts have been tightened.</p>		
<p>Ensure Crimped Fittings have been installed as per installation manual and the swage section has 5 crimps, first swage is 6mm from the depth indicator.</p> 		
<p>Ensure Retro Washers have silicone applied. Visually inspect the washer and waterproofing components to ensure it has remained sealed.</p>		

LIFELINE AND LADDER STABILISERS INSTALLATION AND RECERTIFICATION CHECKLIST

<p>Check that the correct amount of Rivets have been used on surface mounted anchors/lifeline. Check the rivets have been installed and secured correctly.</p>  <p>Ensure mandrel is seen just below the sealing mound. The sealing mound needs to be connected to the top of the mandrel to ensure waterproofing is maintained. Additional waterproofing measures may be required. Pictures show a correctly deployed rivet. Ensure green seal is in place and functional between rivet top and anchor surface to ensure waterproofing is maintained.</p> 		
<p>Installed onto Roof Sheet laps/joins. Check that ten (10) rivets have been used to install the SurfaceLink Plate. Check the rivets have been installed and secured correctly.</p>		
<p>Installed onto Roof Sheet screw line. Check one roofing screw is installed in centre hole of plate on each side.</p>		
<p>Drilled in anchorages such as friction or glued-in anchorages must be tested after installation and at every recertification inspection. Ensure you wait the recommended curing time as specified by the chemical anchor instructions. The pull test can be done using a 16mm threaded eyebolt. Test consists of ultimate pull out force proof loading to 50% of design purpose of anchorage.</p> 		
<p>S5_Z Clamps should be checked to ensure the setscrews are tensioned to 160 and 180 inch pounds on 22ga steel, and 130 to 150 inch pounds on all other metals and thinner gauges of steel (see installation guides).</p> 		
<p>Ensure fixing bolt on the top of the S-5 Clamp is tightly secured.</p> 		

LIFELINE AND LADDER STABILISERS INSTALLATION AND RECERTIFICATION CHECKLIST

INDIVIDUAL ANCHOR AND COMPONENT CHECK	Insert number code for NON COMPLYING anchors or components (per site plan).	ACTION TAKEN to rectify non complying anchors.
<p>SL Clamp - Check and ensure SL clamps are installed correctly, each end bracket and corner brackets to be installed by six numbers of clamps and intermediate brackets to be installed by four numbers of clamps.</p> 		
<p>SL Clamps should be checked to ensure the Bolts/Nuts are tensioned to 16Nm (Newton metre) on all other metals and thinner gauges of steel (see installation guides).</p> 		
<p>Ensure fixing bolt on the top of the SL Clamp is tightly secured.</p> 		
<p>SafetyLink Horizontal Lifelines must be installed to roofs pitches no greater than 25 degrees.</p>		
<p>Surface Mounted Anchors should be positioned no less than 2 metres from the edge on clip down/standing seam style roof profiles unless additional securing of roof sheeting is made.</p>		
<p>Run the FrogLine Shuttle along the full length of the life line to verify its correct function.</p>		

WARNINGS

During installation you must be safe at all times. All safety procedures must be complied with in accordance with the current legislation and regulations. Ensure safety at all times by being attached to anchor point approved safety equipment, using a scaffold or a secured ladder.

All items of equipment which are in regular use shall be subjected to periodic inspection and servicing. These regular scheduled inspections and servicing must be carried out by a competent height safety installer. (refer to AS/NZS 1891.4:2009 if clarification required or contact us). The building or structure for the anchorages should be assessed by an engineer, unless it is clear to a competent height safety installer that the anchorages system is structurally adequate.

INSTALLATION MUST BE CARRIED OUT BY, OR UNDER THE SUPERVISION OF A COMPETENT HEIGHT SAFETY INSTALLER.

If you are uncertain and need help please call +61 249 641068 or 1300 789545,
email: info@safetylink.com or visit our website www.safetylink.com

LIFELINE AND LADDER STABILISERS INSTALLATION AND RECERTIFICATION CHECKLIST

10 YEAR RECERTIFICATION POLICY

10 years from the date of original installation SafetyLink Lifeline/Anchor Systems must be inspected by a suitably qualified engineer or competent height safety installer as defined in AS/NZS 1891.4:2009 clause 1.4 DEFINITIONS. The engineering level of inspection required must be carried out as follows:

Summary of requirements after 10 years from original installation date:

- a) The system is to be inspected to ensure it is installed as per SafetyLink's installation instructions.
- b) The system is to be inspected to ensure it passes the annual recertification criteria as set out in SafetyLink's *Installation and Recertification Checklist*.
- c) The structure is to be assessed for any modifications or deterioration which might lead to loss of anchorage strength, and either deemed safe for continued use or taken out of service.

Every 5 years after the 10 year Engineer recertification the SafetyLink Lifeline/Anchor Systems must be inspected by a suitably qualified engineer or competent height safety installer as defined in AS/NZS 1891.4:2009 clause 1.4 DEFINITIONS. The engineering level of inspection required must be carried out as follows:

Summary of requirements after 5 years from 10 year inspection date:

- a) The system is to be inspected to ensure it is installed as per SafetyLink's installation instructions.
- b) The system is to be inspected to ensure it passes the annual recertification criteria as set out in SafetyLink's *Installation and Recertification Checklist*.
- c) The structure is to be assessed for any modifications or deterioration which might lead to loss of anchorage strength, and either deemed safe for continued use or taken out of service.

WARNINGS

During installation you must be safe at all times. All safety procedures must be complied with in accordance with the current legislation and regulations. Ensure safety at all times by being attached to anchor point approved safety equipment, using a scaffold or a secured ladder.

All items of equipment which are in regular use shall be subjected to periodic inspection and servicing. These regular scheduled inspections and servicing must be carried out by a competent height safety installer. (*refer to AS/NZS 1891.4:2009 if clarification required or contact us*).

The building or structure for the anchorages should be assessed by an engineer, unless it is clear to a competent height safety installer that the anchorages system is structurally adequate.

INSTALLATION MUST BE CARRIED OUT BY, OR UNDER THE SUPERVISION OF A COMPETENT HEIGHT SAFETY INSTALLER.

**If you are uncertain and need help please call +61 249 641068 or 1300 789545,
email: info@safetylink.com or visit our website www.safetylink.com**

PERMANENT LADDER SYSTEM INSTALLATION AND RECERTIFICATION CHECKLIST

This checklist is to help you compile information about the SafetyLink Ladder System to ensure it is installed and maintained as per SafetyLink Installation Guides.

All ladders, ladder components and swaged/swageless/crimped components must be inspected every 12 months, inspections need to be carried out by a competent height safety equipment inspector who has been trained in the safe use and maintenance of this system. The system will require re-certification by height safety assessor "suitable qualified engineer or competent height safety installer as defined in AS/NZS 1891.4:2009 clause 1.4 DEFINITIONS" where the systems original date of installation exceeds 10 years, and every subsequent 5 years after that.

All ladders must be numbered and tagged as compliant at installation and re-tagged on re-certification. Tag number codes are to be used in conjunction with a site plan.

NOTE: THIS CHECKLIST IS TO BE USED IN CONJUNCTION WITH A SITE LAYOUT PLAN AND SAFETYLINK INSTALLATION GUIDES AND USER MANUALS.



Date checklist completed: ____/____/____	
Date checklist to be redone (annually or when there is a change or addition to the system): ____/____/____	
Name(s) of person(s) who completed checklist:	
Position:	Company:

OVERALL CHECK	ACTION TAKEN IF NO
Review site layout plan, have the ladders been correctly positioned? <input type="checkbox"/> Yes <input type="checkbox"/> No	
Have all ladders and components been tagged and noted on site plan? <input type="checkbox"/> Yes <input type="checkbox"/> No	
Have all ladders been installed as per SafetyLink Installation Guides? <input type="checkbox"/> Yes <input type="checkbox"/> No	

LADDER AND COMPONENT CHECK	Insert number code for NON COMPLYING Ladder or components (per site plan).	ACTION TAKEN to rectify non complying Ladders.
Visually inspect the components of the Permanent Ladder for corrosion. Superficial surface marking is permitted while deeper corrosion or pitting would require attention.		
Inspect stiles and rungs for missing worn damaged twisted or warping of any kind.		
Permanent Ladder should be checked prior to every use and maintained in good condition.		
Under no circumstances shall any temporary repairs be made to any Permanent Ladder.		
Visually inspect the parent structure for modifications or deterioration which might lead to loss of strength.		
Check for the presence of contaminants or exposure to a corrosive or extreme environment which could significantly reduce the working load of the Permanent Ladder System.		
Vertical Lifeline: Check the condition of line tensioners and termination.		
Vertical Lifeline: Check for any evidence of wear, cuts, looseness, extension, interstrand wear, corrosion, stiffness, brittleness or fraying of the steel cable.		



PERMANENT LADDER SYSTEM INSTALLATION AND RECERTIFICATION CHECKLIST

LADDER AND COMPONENT CHECK	Insert number code for NON COMPLYING Ladder or components (per site plan).	ACTION TAKEN to rectify non complying Ladders.
Visually inspect the fixing component of the Permanent Ladder System.		
<p>Check that the correct amount of Rivets have been used on installation. Check the rivets have been installed and secured correctly.</p>  <p>Ensure mandrel is seen just below the sealing mound. The sealing mound needs to be connected to the top of the mandrel to ensure waterproofing is maintained. Additional waterproofing measures may be required. Pictures show a correctly deployed rivet. Ensure green seal is in place and functional between rivet top and anchor surface to ensure waterproofing is maintained.</p> 		
Visually inspect the components of the Permanent Ladder for corrosion. Superficial surface marking is permitted while deeper corrosion or pitting would require attention.		
Vertical Lifeline: Run the Vertical Shuttle along the length of the line to verify its correct function.		

WARNINGS

During installation you must be safe at all times. All safety procedures must be complied with in accordance with the current legislation and regulations. Ensure safety at all times by being attached to anchor point approved safety equipment, using a scaffold or a secured ladder.

All items of equipment which are in regular use shall be subjected to periodic inspection and servicing. These regular scheduled inspections and servicing must be carried out by a competent height safety installer. (refer to AS/NZS 1891.4:2009 if clarification required or contact us).

The building or structure for the anchorages should be assessed by an engineer, unless it is clear to a competent height safety installer that the anchorages system is structurally adequate.

INSTALLATION MUST BE CARRIED OUT BY, OR UNDER THE SUPERVISION OF A COMPETENT HEIGHT SAFETY INSTALLER.

If you are uncertain and need help please call +61 249 641068 or 1300 789545,

email: info@safetylink.com or visit our website www.safetylink.com

EXPERT FALL PROTECTION PLANNING

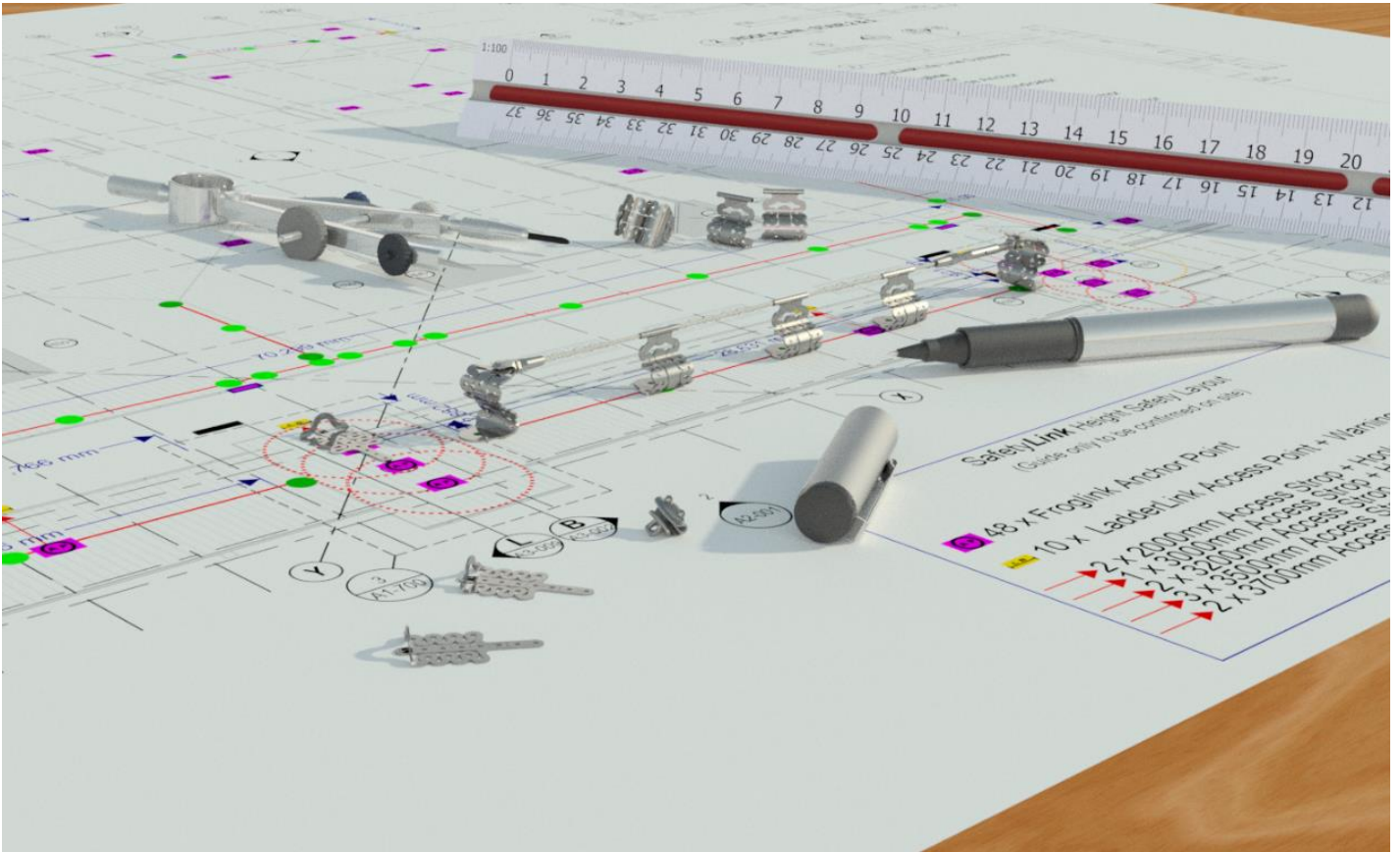

SafetyLink's design and planning team are here to help work out the positioning of your fall protection system, ensuring all areas of your roof are accessed safely.

Things to consider when planning your roof layout:

- ❑ Are all areas of your roof protected, allowing complete access when working at heights?
- ❑ Are you protected from the ground up, allowing complete access to your roof?
- ❑ Detailed comprehensive documentation provided e.g. installation guides, testing results, product sheets should be provided.
- ❑ SafetyLink can also provide you with a qualified and reputable installer of SafetyLink products.

Contact our design team at info@safetylink.com and we can plan your fall arrest system for you.

IN CASE OF ACCIDENT

- ⚠ **A FALL RESCUE PLAN AND SAFE WORK STATEMENT MUST BE DEVELOPED PRIOR TO USING SAFETYLINK SYSTEMS AND EQUIPMENT.**
- ⚠ **PERSONS WORKING AT HEIGHTS SHOULD NOT WORK ALONE.**

It is critical that before using any SafetyLink Systems a fall rescue plan is in place for any persons suspended mid-air following a fall. Serious injury or death can occur in a matter of minutes, particularly if a person's movement or breathing is restricted or loss of consciousness has occurred. In accordance with your fall rescue plan and appropriate first aid procedures it is essential to remove the person from the suspended position as quickly as possible.

IN ACCORDANCE WITH AS/NZS 1891.4:2009 CLAUSE 9.5

EQUIPMENT WHICH HAS ARRESTED A FALL OR SHOWS A DEFECT

Any piece of equipment including both personal and permanently installed items, which has been used to arrest a fall or which shows any defect during operator or periodic inspection shall be withdrawn from service immediately and a replacement obtained if necessary. A label indicating the condition or defect should be attached to the equipment, and it should be examined by a competent height safety installer who will decide whether the equipment is to be destroyed or repaired if necessary and returned to service. In the latter case, details of any repair shall be documented, and a copy given to the operator.



Terms/Conditions/Warranties

DISTRIBUTOR:

SafetyLink Pty Ltd | ABN 83 081 777 371

Phone: 1300 789 545 or +61 2 4964 1068 | Fax: 1300 738 071 or +61 2 49641069

info@safetylink.com | www.safetylink.com