

SAFETYLINK

A DELTA PLUS GROUP COMPANY

FrogLine

Horizontal Lifeline

Installation and Use

FIGURE 1

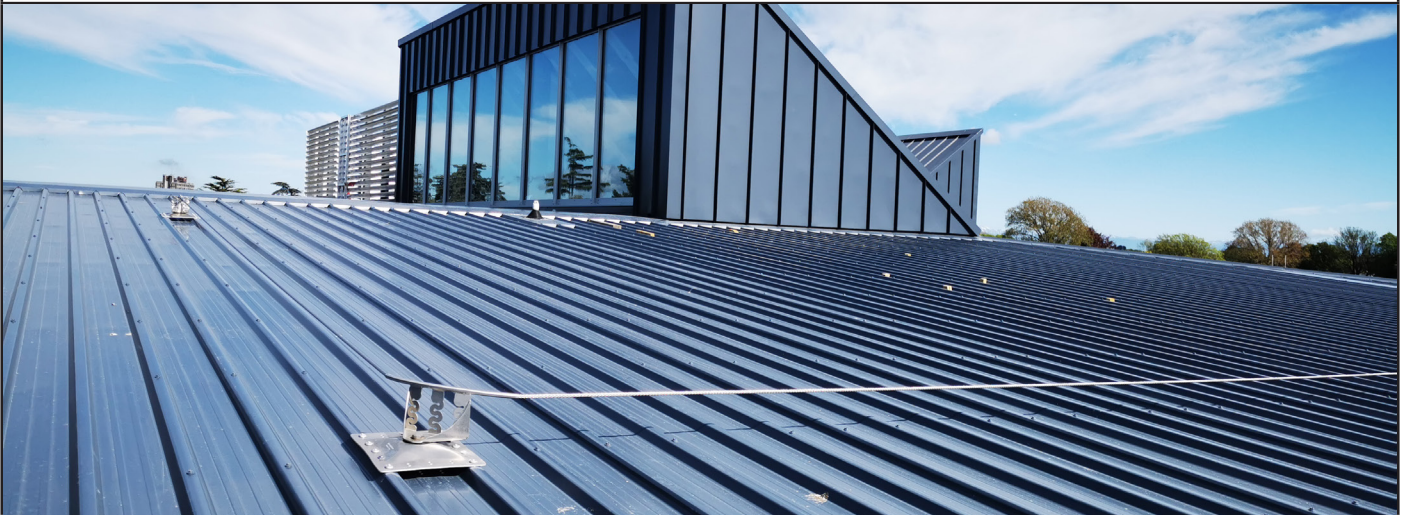

CONTENTS

1	Warning	4
2	Specification	4
	2.1 Description.....	4
	2.2 Standard	4
	2.3 User Rating	4
	2.4 System Substrate.....	4
	2.5 Material Specification and Components.....	5
	2.6 Surface Mounted Plates	9
3	Layout and Selection	10
	3.1 System Design	10
	3.2 Structure	10
	3.3 Spans	11
	3.4 Tensioner	11
	3.5 Joins.....	12
	3.6 Reaction Loads	12
	3.7 Corners.....	12
	3.7.1 Wall Mounted (2x Intermediate and Corner Tube)	12
	3.7.2 Overhead (2x Intermediate and Corner Tube).....	13
	3.7.3 Corners with Extended Intermediates	14
	3.7.4 Corners with multiple Extended Intermediates	14
	3.8 Overhead Ends.....	14
4	Installation	15
	4.1 Fixings.....	15
	4.1.1 Hex Screws and Bolts.....	15
	4.1.2 Rivets	15
	4.1.3 Screws	15
	4.1.4 Concrete 3rd Party.....	15
	4.2 Proof Loading	15
	4.3 Tuff-Post.....	16
	4.4 Tuff-Bracket.....	16
	4.5 BeamLink	16
	4.6 SteelLink	17
	4.7 Cable Installation.....	18
	4.8 Cable End.....	19
	4.8.1 Crimped Terminations and Tensioners.....	19
	4.8.2 Swageless Terminations and Tensioners	20
	4.9 Join.....	21
	4.10 Bending Extended Intermediates	22
	4.11 Concrete.....	23
	4.11.1 Concrete Studs M16	23
	4.11.2 Concrete Studs M12	24
	4.11.3 Concrete Inserts	25
	4.11.4 Tuff Post.....	26
	4.12 Steel	27
	4.12.1 M16 Bolt	27
	4.12.2 M12 Bolt	27
	4.12.3 Tuff Post.....	28

4.13	Core filled Blocks.....	29
4.14	Retro.....	30
4.15	Overhead Purlin (RafterLink).....	31
	4.15.1 Direct to Purlin.....	31
	4.15.2 Suspended from Purlin.....	32
4.16	Surface.....	33
	4.16.1 General.....	33
	4.16.2 Plate Assembly.....	34
	4.16.3 Screw Down Profiles (Trimdek, Custom Orb etc.).....	35
	4.16.4 Clipping Profile (Kliplok Speedek Ultra, Standing Seam, KingZip etc.)....	36
	4.16.5 Raised Plates.....	40
	4.16.6 MaxLine.....	43
	4.16.7 Brownbuilt (Side Fixing).....	45
	4.16.8 Brownbuilt (Top Fixing).....	47
	4.16.9 Plywood.....	49
	4.16.10 Sandwich Panels (100mm and greater).....	50
4.17	Membrane.....	51
4.18	Clamps.....	52
	4.18.1 FastFit Clamp (KlipLok 700).....	52
	4.18.2 S5 Clamps.....	53
	4.18.3 S5-Z Clamps.....	54
5	Limitations of Use	55
5.1	Fall Clearance.....	55
5.2	Swing Fall.....	55
5.3	Hazards.....	56
5.4	Training.....	56
5.5	Rescue.....	56
5.6	Connection System.....	56
6	Connections	57
6.1	Making Connection.....	57
6.2	Compatibility of Connections.....	57
7	Use	58
7.1	Planning.....	58
7.2	FrogLine Shuttle.....	58
7.3	Overhead Shuttle.....	59
7.4	Shuttle Operation.....	60
8	Storage, Transport and Maintenance	61
8.1	Storage and transport.....	61
8.2	Maintenance.....	61
8.3	Cleaning.....	61
9	Inspection	61
9.1	Before and After Use.....	61
9.2	Competent Person.....	61
9.3	Procedure.....	61
9.4	Proof Load.....	61

1 Warning

- ⚠ Improper Use, Installation or Maintenance may result in serious injury or death.**
- ⚠ The structure or anchorage to which SafetyLink products are to be installed shall be assessed by a professional engineer to ensure it has adequate strength to support the product.**
- ⚠ SafetyLink products shall be installed, used and maintained in accordance with the applicable SafetyLink installation and use manual.**
- ⚠ SafetyLink's product shall be used in accordance with the current working at height standards, codes of practice, regulation or legislation in the region of use.**
- ⚠ During installation, use and maintenance, personnel shall not be exposed to a fall hazard.**
- ⚠ Installation is to be carried out by, or under the supervision of, a competent person.**
- ⚠ The installer shall complete the applicable SafetyLink online training modules before installing this product.**
- ⚠ Connection systems used with SafetyLink Anchor, Lifelines and Rigid Rail Systems shall contain a personal energy absorber.**
- ⚠ Do not carry out any modifications to this product without written permission from SafetyLink.**

2 Specification

2.1 Description

The FrogLine is a Horizontal Lifeline suitable for use as part of a personal fall protection system. The system comprises a permanently installed horizontal cable with a number of shuttles for users to attach to. The shuttles are free to traverse the length of the cable.

2.2 Standard



The FrogLine Horizontal Lifeline is compliant with AS/NZS 1891.2, ANSI Z359.6, EN795 and CEN/TS16415.

2.3 User Rating

The FrogLine is rated for up to 2 users per span, 4 users per system with a maximum individual weight of 150kg.

- ⚠ Never connect more than one user to each shuttle.**

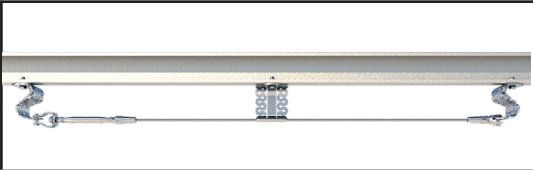
2.4 System Substrate

FIGURE 2		
IMAGE	SYSTEM	SUBSTRATE
	Overhead	The overhead system is designed to be mounted above the work area and is suitable for installation on steel or concrete structures.
	Wall	The wall system is designed to be mounted to a wall or parapet and is suitable for installation on steel or concrete structures.
	Floor	The floor mounted system is designed to be mounted at foot level. It is suitable for installation on steel or concrete structures and roof sheeting materials.

2.5 Material Specification and Components

FIGURE 3



FROGLINE END



FROGLINE INT



FROGLINE INT_EXT



FROGLINE CNR



FROGLINE END_OH



FROGLINE INT_OH



FROGLINE CNR_OH_INT

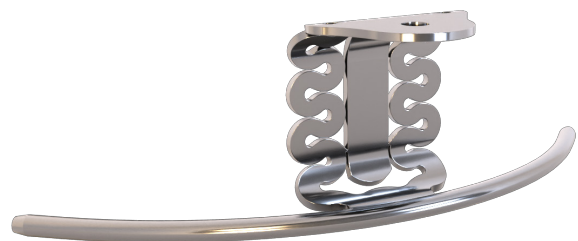

FROGLINE CNR_OH_EXT

	
<p>Corner Tube: STAT.CTUBE001</p>	<p>FROGLINE CORNER_WALL</p>
	
<p>Swageless Tensioner with Tension Indicator: STAT.TENSR004</p>	<p>Crimped Tensioner with Tension Indicator: STAT.TENSR005</p>
	
<p>Swageless Termination: STAT.TERMN002</p>	<p>Crimped Termination: STAT.TERMN003</p>
	
<p>Cable Joiner: STAT.CABJOIN</p>	<p>Steel Fixing: STEELINK-M12.HEX.75.12.M16</p>

	
<p>Concrete Fixing: CON-M12x130-XDONUT-FL</p>	<p>Concrete Fixing: CON-M16x130-DONUT</p>
	
<p>Concrete Insert M16: CON-INSERT</p>	<p>Rivet_8mm(27.7)</p>
	
<p>RETRO-TUBE</p>	<p>Extension 63.5ODx35mm: STAT.FROGRET001.01</p>
	
<p>Extension 63.5ODx55mm: STAT.FROGRET001.02</p>	<p>Extension 63.5ODx90mm: STAT.FROGRET001.03</p>



Screw 14g



TOGGLE001

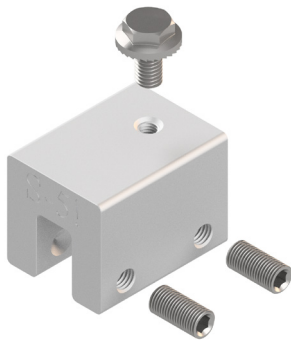

S5_S_BRACKET

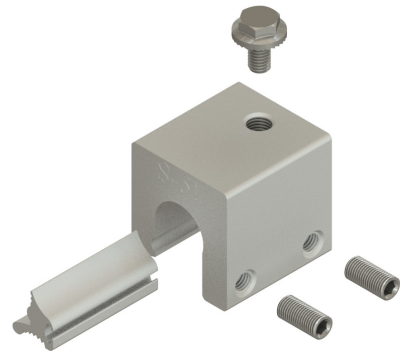

S5_Z_BRACKET



SL CLAMP.KL700



FrogLine Pipe Bender: STAT.FROG.BEND



Horizontal Lifeline Shuttle: STAT.SHUTL005

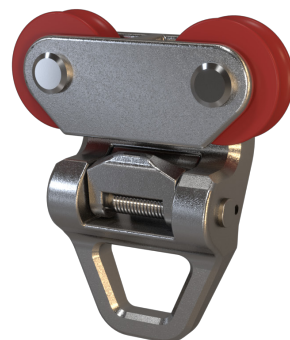

Overhead Lifeline Shuttle: STAT.SHUTL006

2.6 Surface Mounted Plates

FIGURE 4

ITEM	LENGTH MM	WIDTH MM	THICKNESS MM	MATERIAL	HOLES	HOLE SPACING
ADV-PLATE-AL-305	305	243	3	Aluminium	N	N/A
ADV-PLATE-AL-305-M	290	230	3	Aluminium	Y	191,203,231,263
ADV-PLATE-AL-370	370	243	3	Aluminium	N	N/A
ADV-PLATE-AL-370-M	370	243	3	Aluminium	Y	290,300,318,333
ADV-PLATE-AL-450	450	243	3	Aluminium	N	N/A
ADV-PLATE-AL-450-S5_Z	450	243	3	Aluminium	Y	400
ADV-PLATE-SS-290x237.5x67	290	237	2	Stainless Steel	Y	213
ADV-PLATE-SS-295SQ-BOLT	295	295	1.5	Stainless Steel	Y	235
ADV-PLATE-SS-295SQ-NUT	295	295	1.5	Stainless Steel	Y	235
ADV-PLATE-SS-305-M	290	230	2	Stainless Steel	Y	191,203,231,263
ADV-PLATE-SS-370-H-290	370	243	2	Stainless Steel	Y	290
ADV-PLATE-SS-370-H-318	370	243	2	Stainless Steel	Y	318
ADV-PLATE-SS-370-H-333	370	243	2	Stainless Steel	Y	333

☑ For surface plates with different dimensions please contact SafetyLink for more information.



3 Layout and Selection

3.1 System Design

Systems shall be designed to limit free fall, swing fall and maximise fall clearance. Where possible, systems shall be designed to prevent a free fall from occurring.

All dimensions unless stated as min or max are $\pm 5\text{mm}$.

The FrogLine Horizontal Lifeline shall be installed on an angle no greater than 15 degrees up the pitch and 25 degrees across the pitch.

⚠ As per AS/NZS 1891.4 free fall shall not exceed 2m.

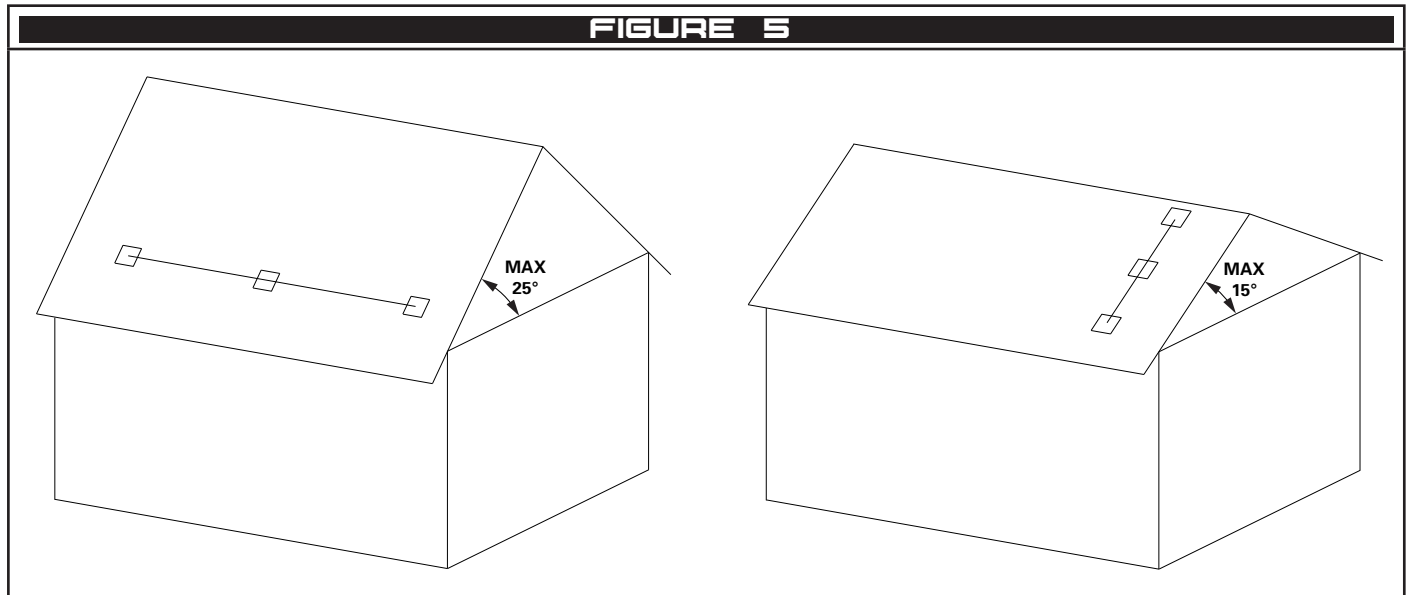

3.2 Structure

Unless stated otherwise:

- I All steel roof sheeting shall be a minimum of 0.42mm thick.
- II All aluminium roof sheeting shall be a minimum of 0.7mm thick.
- III Purlins shall be minimum 150x50x1.2mm thick.
- IV Purlin spacing shall not exceed 1200mm.
- V The minimum number of purlins shall be 2.
- VI Risers shall not exceed 120mm tall.
- VII Plywood shall be at least 15mm thick.

For structures outside these specification please contact SafetyLink for more information.

3.3 Spans

The span length shall not exceed 10m as per Figure 6. For systems with more than one corner, the span length may need to be reduced to enable proper tensioning.

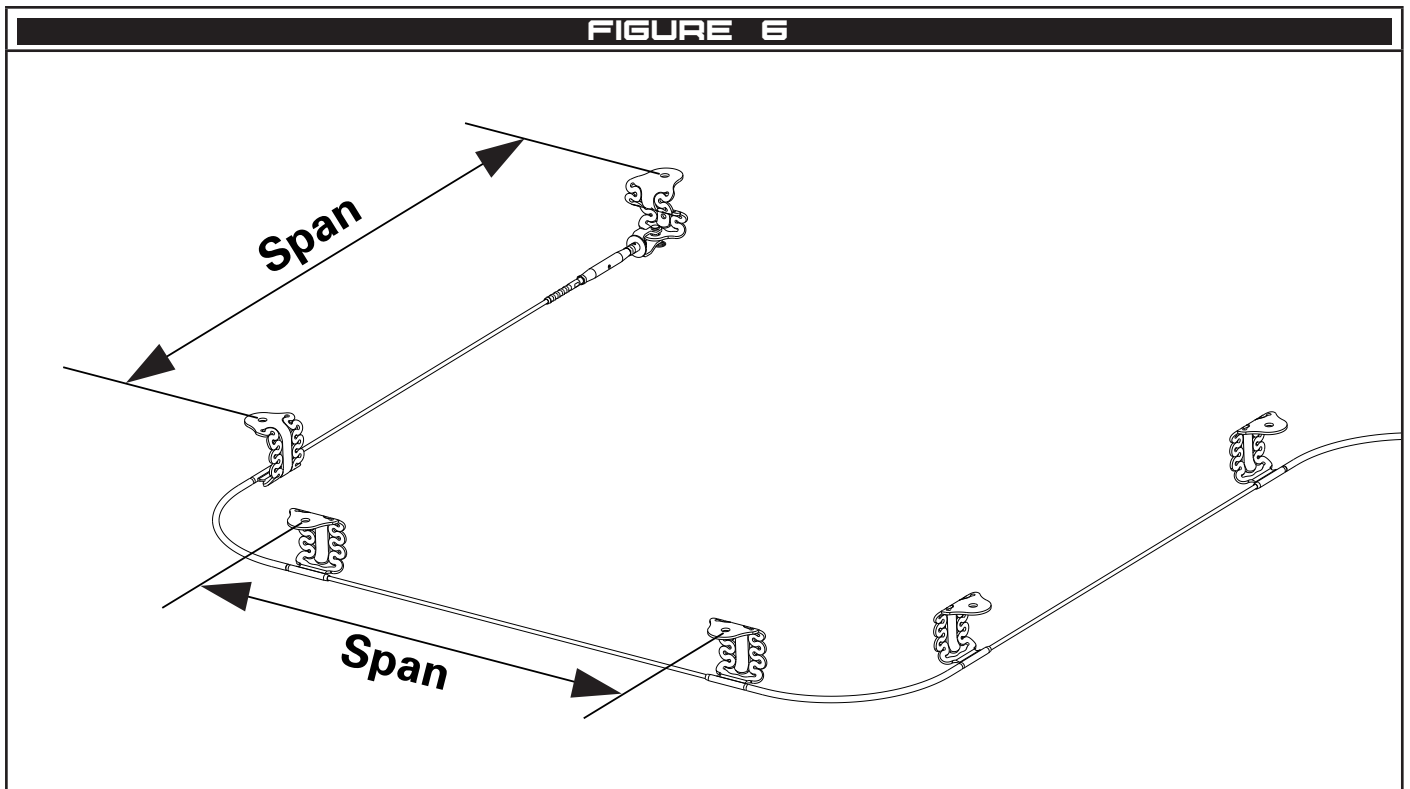

3.4 Tensioner

System with more than 2 corners or over 100m long shall have a tensioner at each end to help tension the line.

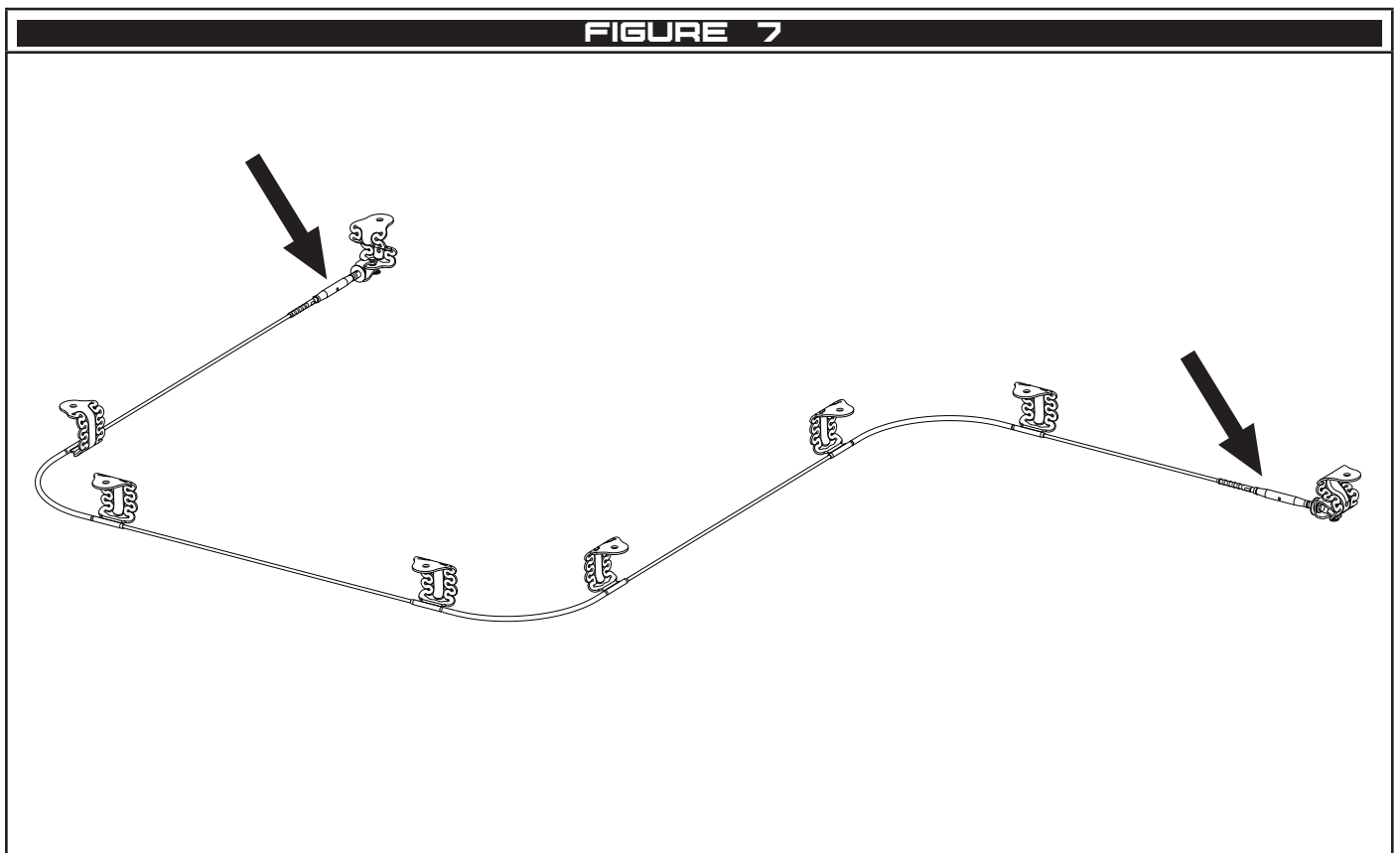

3.5 Joins

Joins in the cable can be made with a cable joiner at any location in the system.

3.6 Reaction Loads

The supporting structure and fixings used shall be capable of sustaining the below load cases where applicable. Load can be determined using the FrogLine calculator at:

<https://safetycentre.safetylink.com/>

⚠ All load cases shall be considered by a trained engineer.

3.7 Corners

Corners in the FrogLine system can be configured in different ways to suit a variety of structures. Below are the required dimension for corners configured from more than one part.

3.7.1 Wall Mounted (2x Intermediate and Corner Tube)

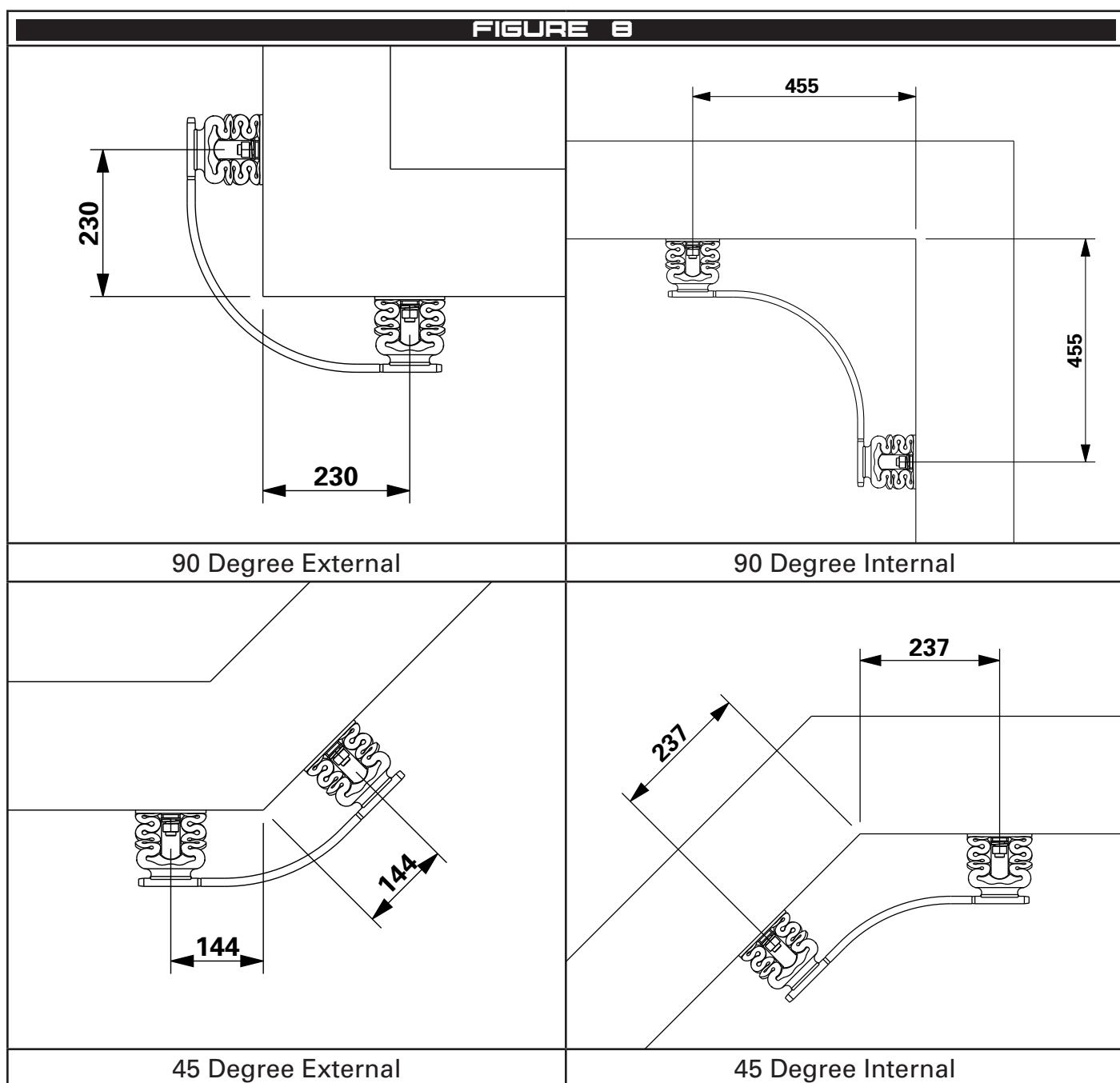

3.7.2 Overhead (2x Intermediate and Corner Tube)

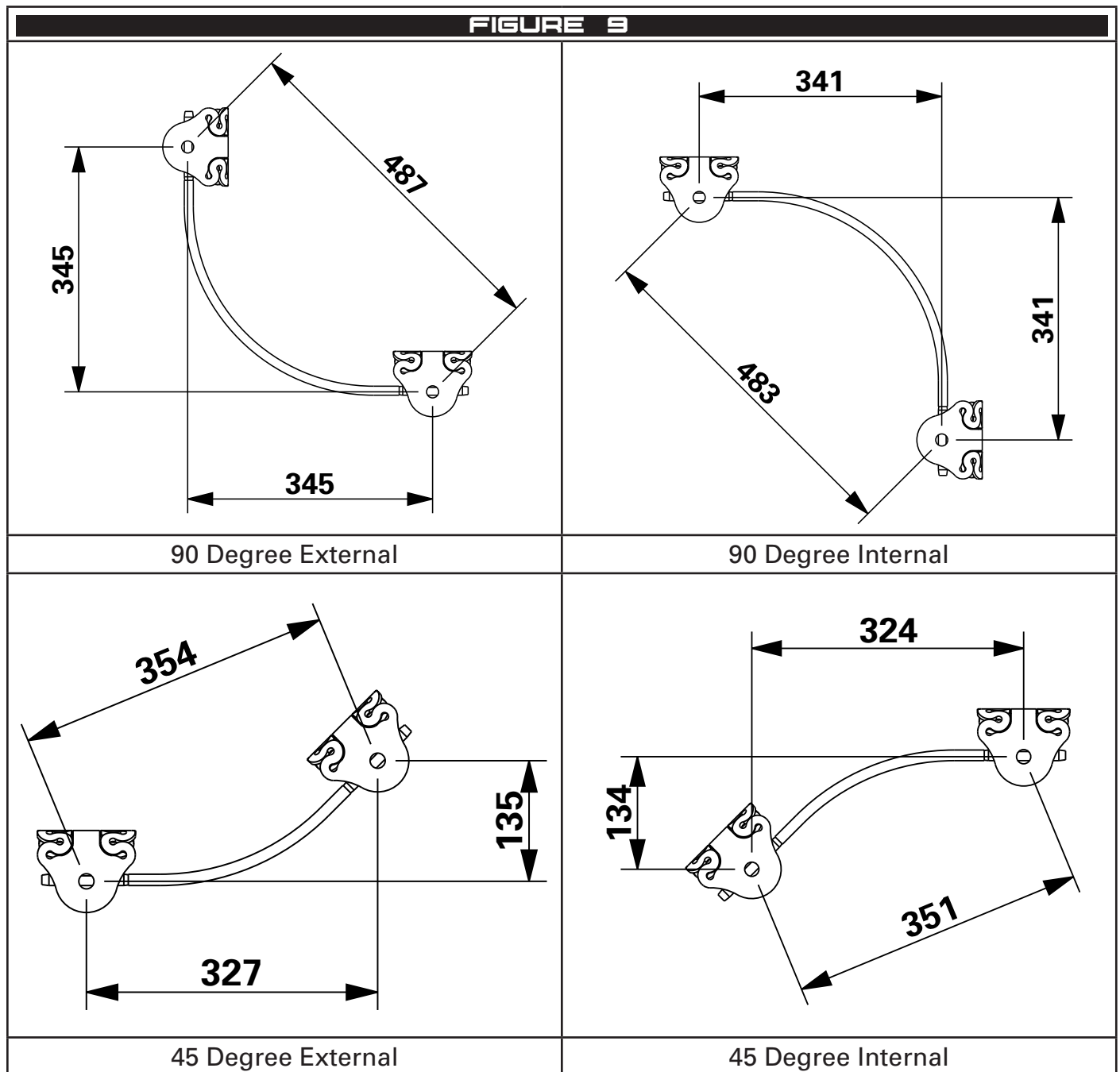

3.7.3 Corners with Extended Intermediates

Extended Intermediate brackets can be used to create corners with up to 30 degrees of cable deviation each side (60 degrees per bracket). The Extended Intermediate can be bent in any direction up to 30 degrees with a minimum bend radius of 260mm to ensure the shuttle passes. See Section 4.10 for bending instructions.

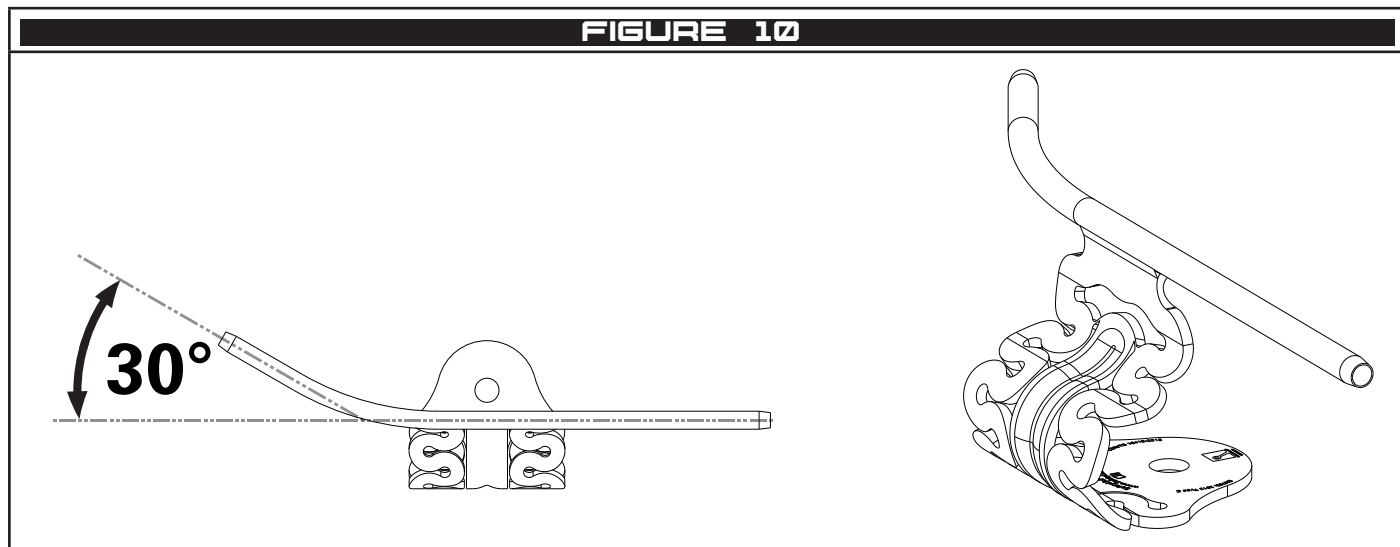

3.7.4 Corners with multiple Extended Intermediates

Multiple Extended Intermediates can be used to create deviations of larger than 60 degrees.

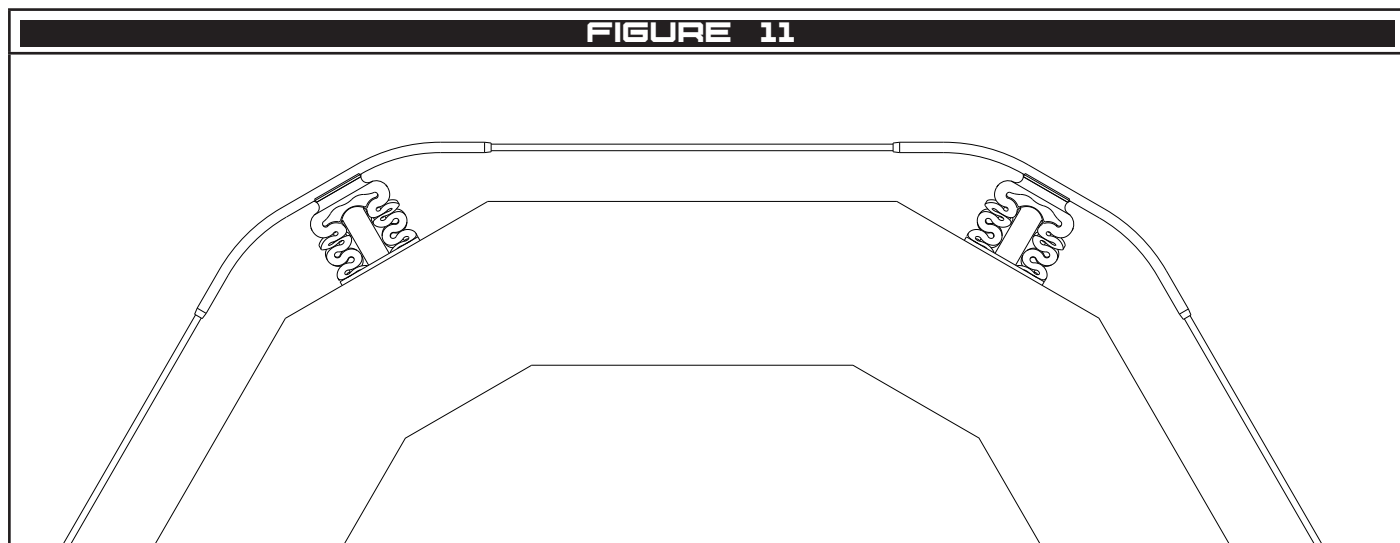

3.8 Overhead Ends

DONUTLINK pull test adaptor is not suitable for use with overhead end brackets due to the reinforcing spline. For concrete installation, Overhead End brackets shall be installed as per Section 4.11.3.

4 Installation

4.1 Fixings

4.1.1 Hex Screws and Bolts

All fixings used to attached the FrogLine system to the substrate shall be M12 (1/2") or M16 (5/8") in diameter. Fixings shall be stainless steel grade 316 or 304 or hot dip galvanised or zinc plated steel grades 8.8 or 8. Fixings shall be installed with spring washers, lock nuts or thread lock adhesive to prevent loosening.

⚠ SafetyLink does not recommended the use of zinc plated fasteners in a corrosive or outdoor environment.

4.1.2 Rivets

Where rivets are used to fix surface mounted plates, 8mm aluminium trifold rivets shall be used.

✓ Most installations will require RIVET_8mm(27.7) with a grip length of 1.1-9.5mm.

✓ Also available are RIVET_8mm(34) and RIVET_8mm(39) with a grip length of 6.4-15.9mm and 9.5-19.7mm respectively.

4.1.3 Screws

Where screws are used to fix a surface mounted plate to the structure below the roof sheeting (purlins / plywood), 14 gauge galvanised steel screws of suitable length shall be used.

4.1.4 Concrete 3rd Party

In addition to the part numbers specified in Section 4.11, SafetyLink allows the use of a variety of chemical and mechanical fixings for installation of the FrogLine Horizontal Lifeline into concrete. Refer to the manufacturer's instruction for proper preparation, installation, edge distance and embedded depth.

4.2 Proof Loading

Each bolt shall be axial loaded to 7.5kN and held for 30 seconds.

⚠ Proof loading is only required for chemical and mechanical fixed bases as per AS/NZS1891.4.

4.3 Tuff-Post

The FrogLine may be installed on SafetyLink's Tuff-Posts. Refer to the Tuff-Post instruction handbook for installation methods and limitations of use.

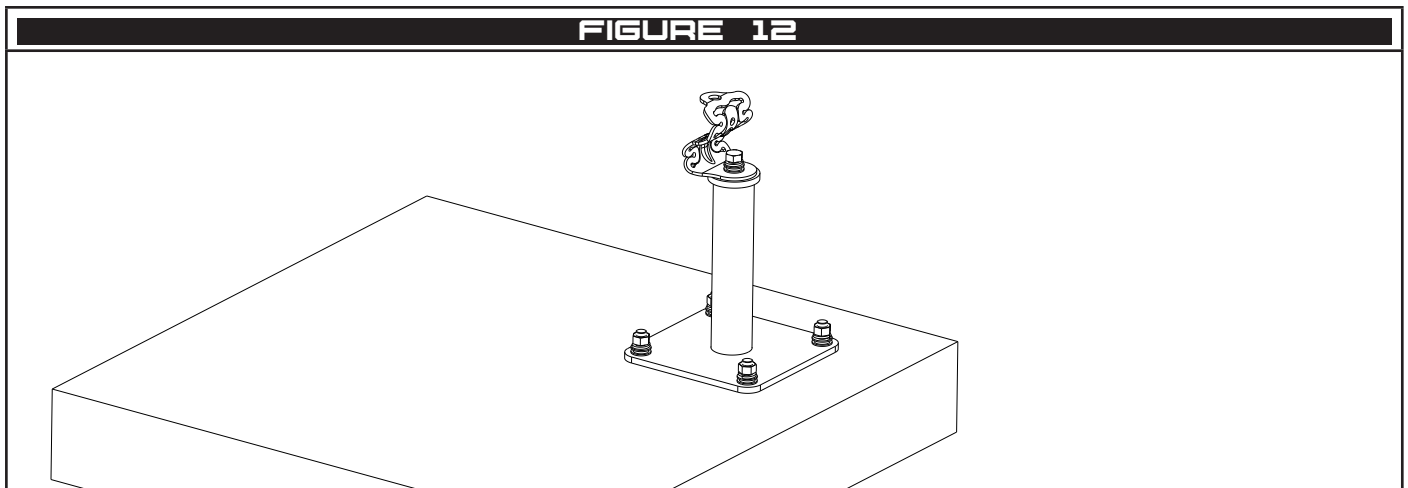

4.4 Tuff-Bracket

The FrogLine may be installed on SafetyLink's Tuff-Brackets. Refer to the Tuff-Bracket instruction handbook for installation methods and limitations of use.

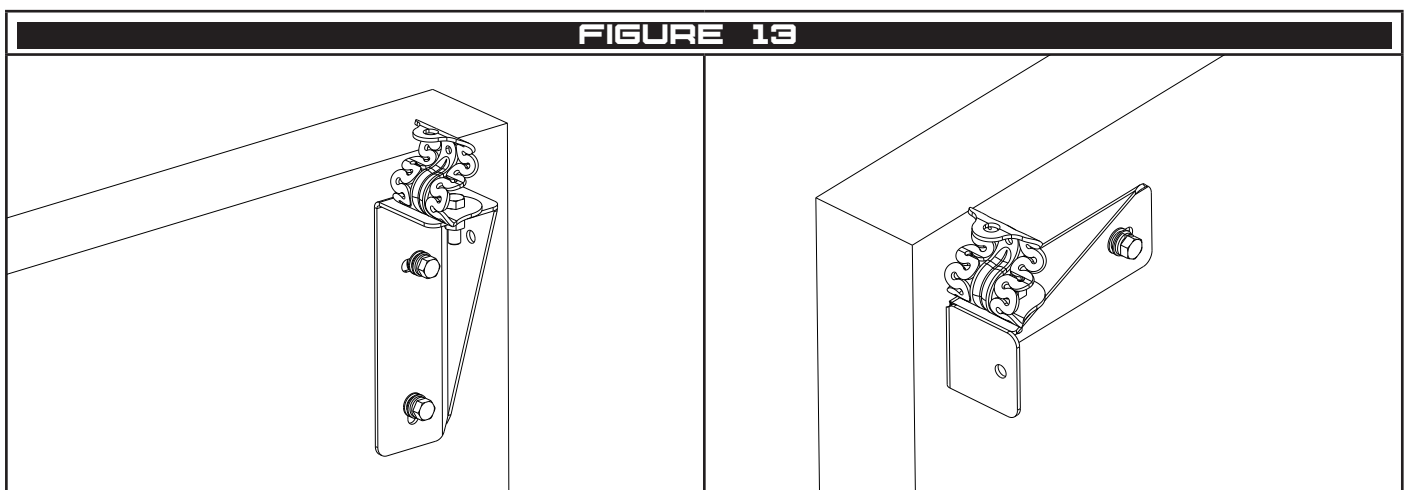

4.5 BeamLink

The FrogLine may be installed on SafetyLink's BeamLink. Refer to the BeamLink instruction handbook for installation methods and limitations of use.

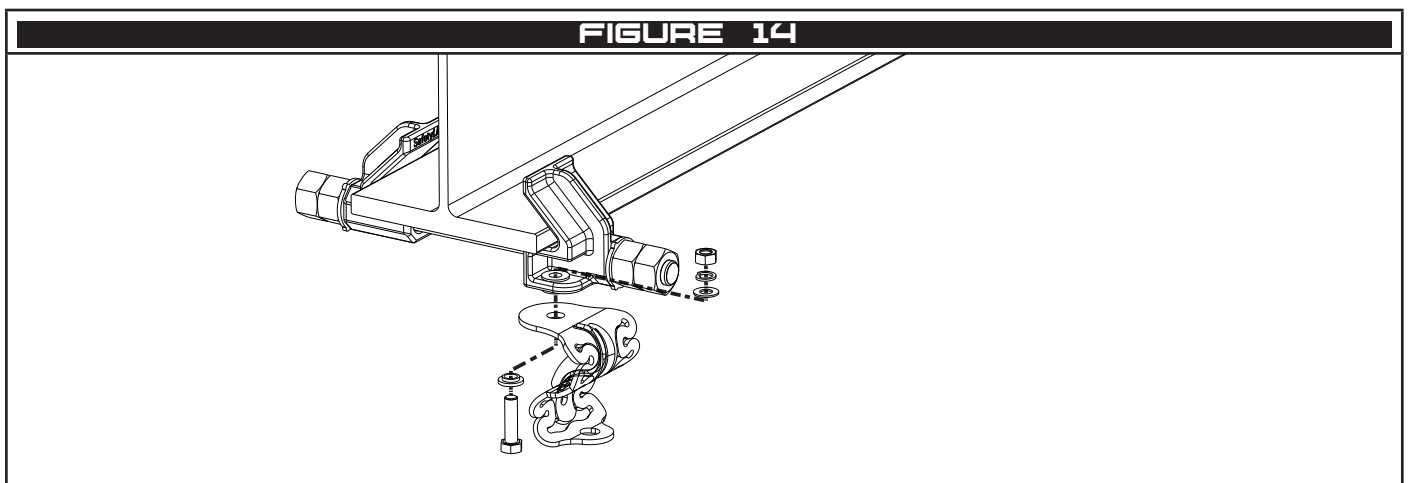

4.6 SteelLink

All the FrogLine may be installed with SafetyLink's SteelLink. Refer to the SteelLink instruction handbook for installation methods and limitations of use.

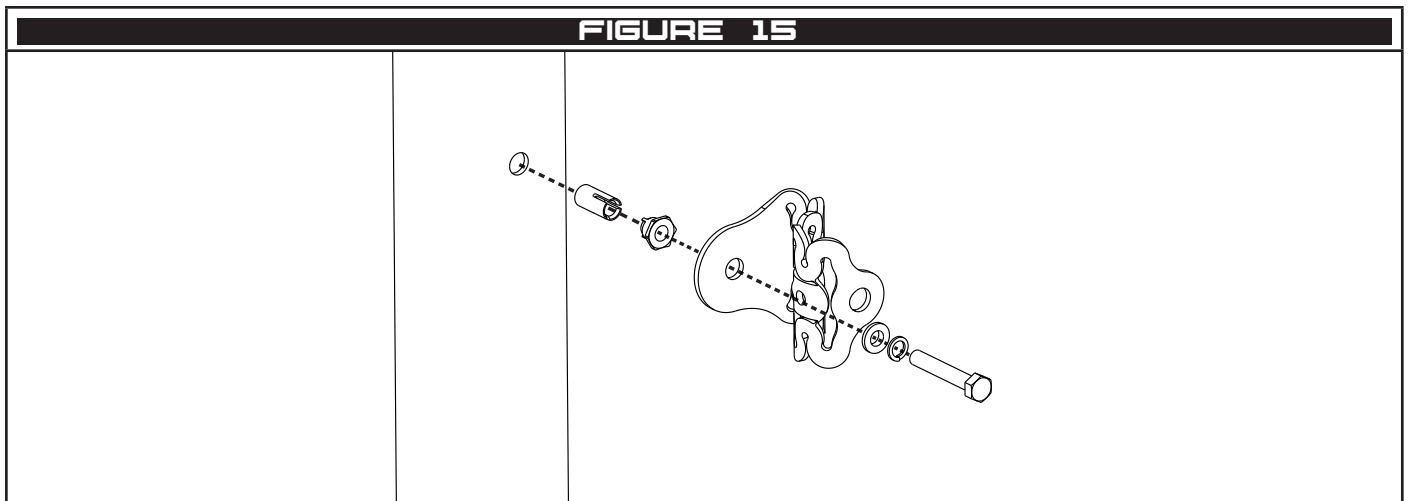

4.7 Cable Installation

- 1 Pass the cable through all the intermediate brackets and corners in the system.
- 2 At one end, install the cable tensioner on the cable as per Section 4.8 and connect it to the end bracket.

! *Ensure the cable tensioner is extended to its maximum length.*

! *Ensure the pin is installed down through the clevis with the retaining ring below the pin.*

- 3 Remove as much slack from the system as possible by hand and at the other end connect a cable termination or tensioner to the end bracket and install as per Section 4.8.
- 4 Using the cable tensioner(s) to tighten the system until the red disc is free to rotate under light pressure. Tighten all the lock nuts on the system.

! *If the disc spins freely without any input, the system is over tensioned.*

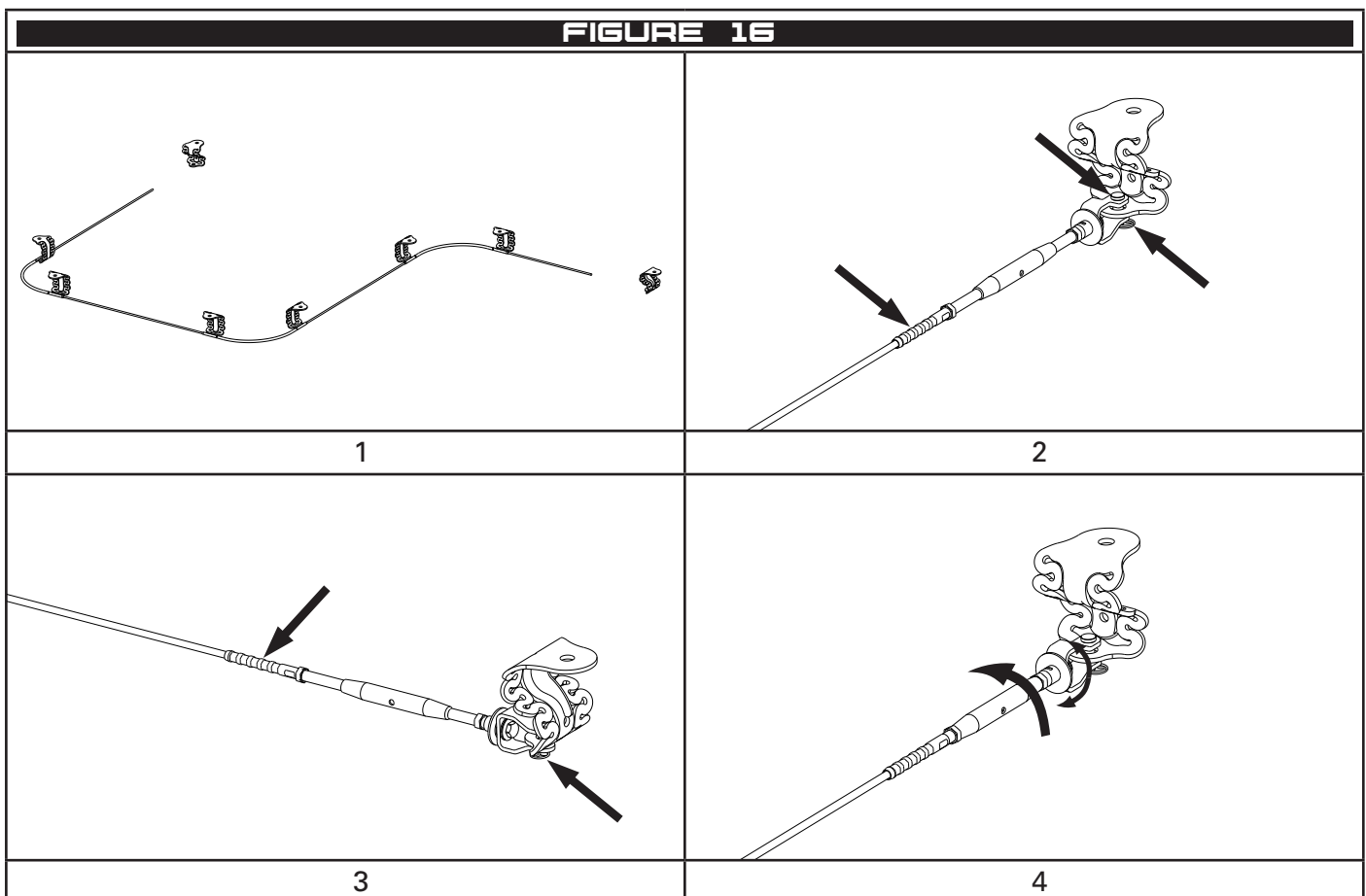

4.8 Cable End

4.8.1 Crimped Terminations and Tensioners

⚠ Only use Ø8mm 1x19, 7x7 or 7x19 stainless steel cable.

- 1 Insert the cable into the termination/tensioner to full depth and mark the cable. Remove the cable and check the mark is at least 84mm from the end of the cable.
- 2 Re insert the cable, ensuring the mark lines up with the end of the fitting.
- 3 Perform the first crimping operation 6mm from the depth line marked on the fitting.
- 4 Perform four more crimping operations each 6mm from the previous as shown below.

⚠ Inspect each of the five crimping operations measures between 11.1mm and 11.9mm between the flat surfaces.

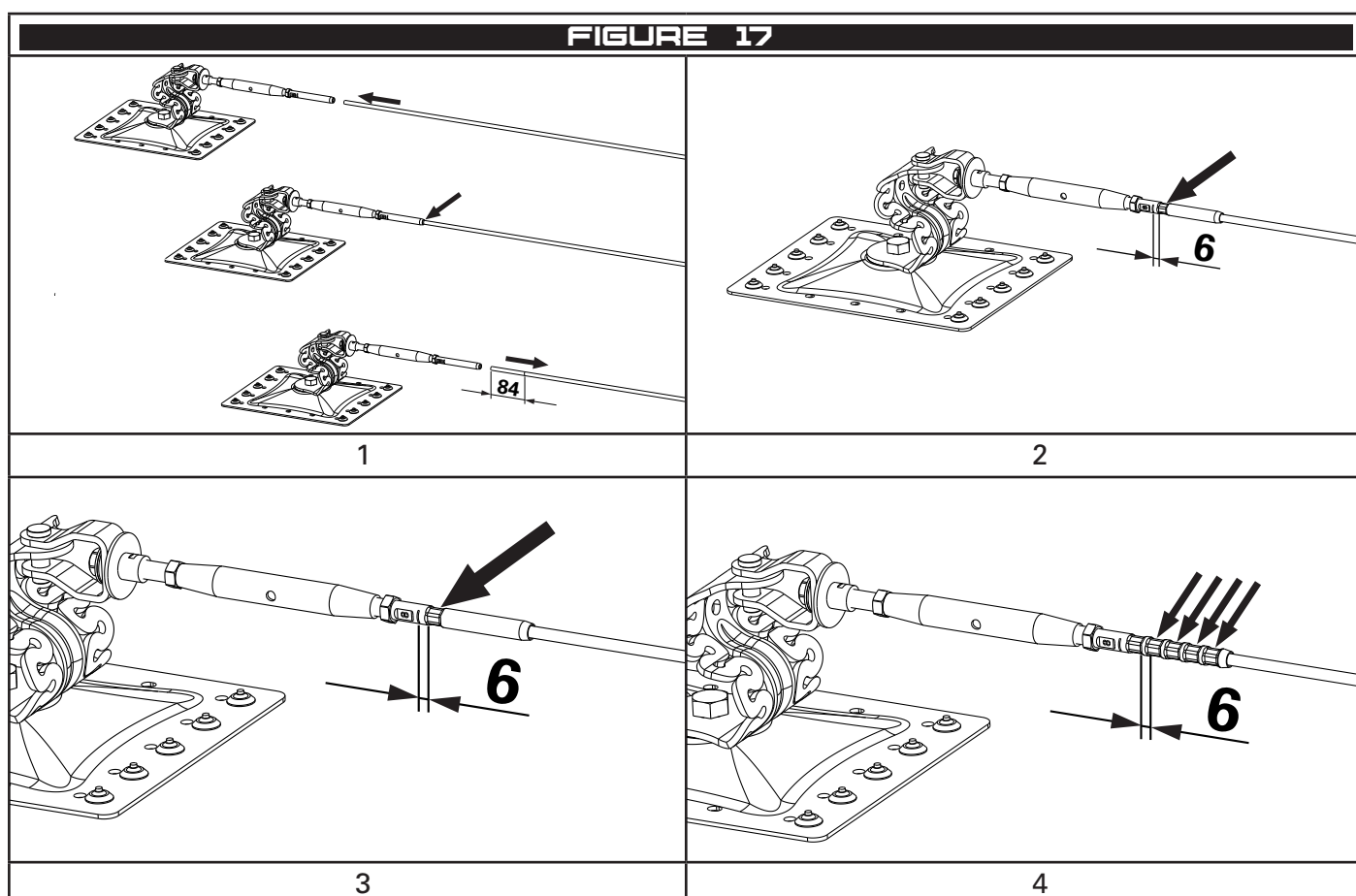

4.8.2 Swageless Terminations and Tensioners

⚠ Only use Ø8mm 7x7 or 7x19 stainless steel cable.

- 1 Install the jaw housing on the cable, followed by the jaws and the retaining ring.
- 2 With 5-8mm of cable precluding past the brass ring, screw the termination or tensioner into the jaw housing and tighten to 58Nm. Tighten the lock nut 50Nm.

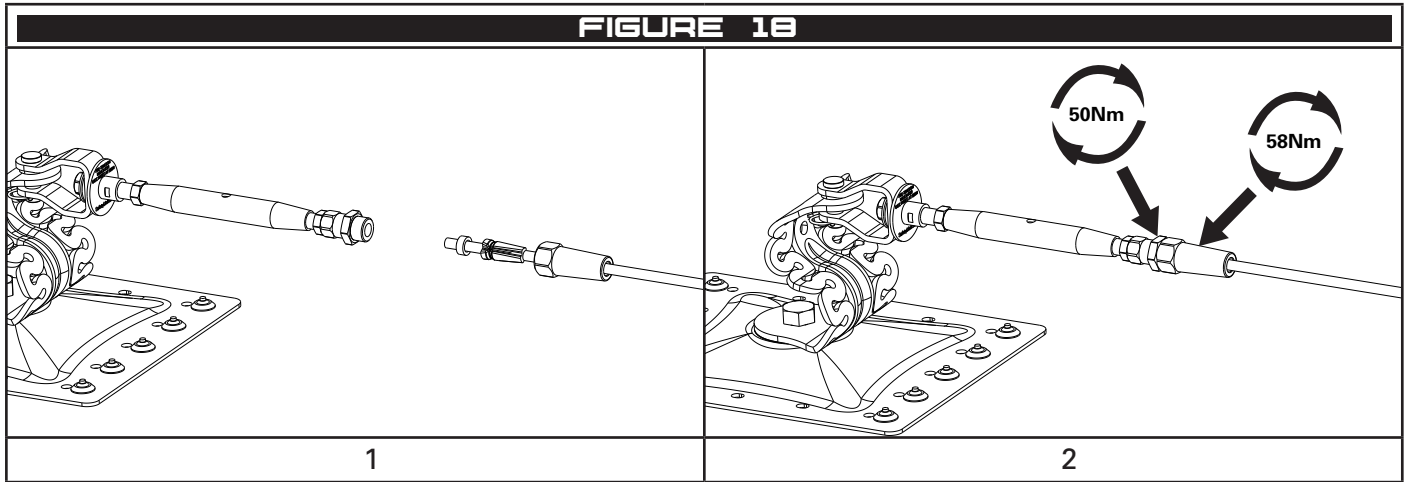

4.9 Join

⚠ Only use Ø8mm 1x19, 7x7 or 7x19 stainless steel cable.

- 1 Insert the cable into one side of the join to full depth and mark the cable. Remove the cable and check the mark is at least 84mm from the end of the cable.
- 2 Re insert the cable, ensuring the mark lines up with the end of the join.
- 3 Perform the first crimping operation 6mm from the depth line marked on the join.
- 4 Perform four more crimping operations each 6mm from the previous as shown below.
- 5 Repeat steps 1 to 4 for the other side of the join.

⚠ Inspect each of the 10 crimping operations measures between 11.1mm and 11.9mm between the flat surfaces.

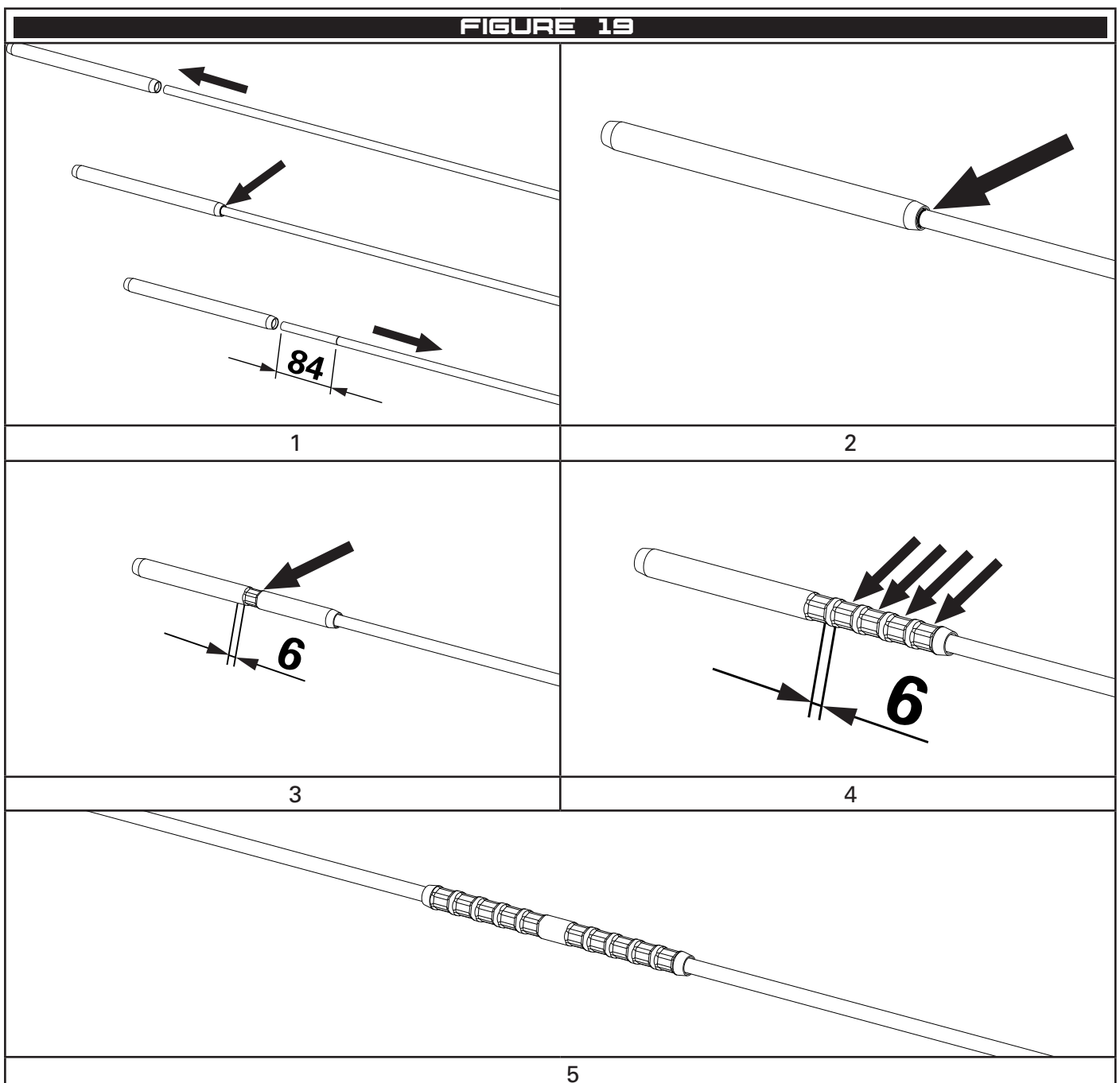

4.10 Bending Extended Intermediates

- 1 Install the Intermediate as per this manual.
- 2 Align the end of the bender with the end of the intermediates tube.
- 3 Support the Intermediate to prevent it spinning and pull the handle of the bend to the desired angle.
- 4 Remove the bender and check the angle noting the tube will have some spring back.

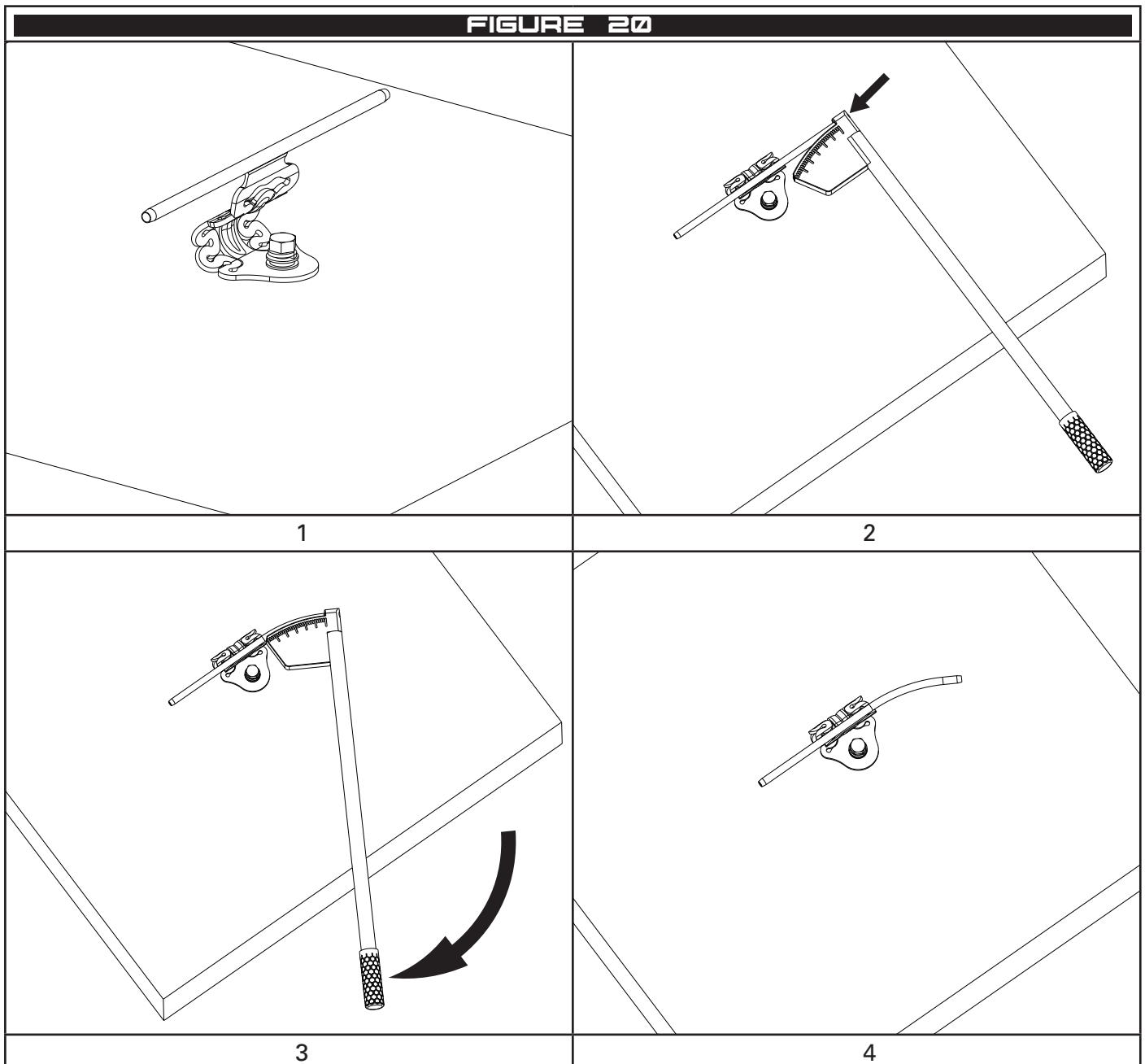

4.11 Concrete

4.11.1 Concrete Studs M16

SafetyLink's DonutLink M16 Concrete Stud CON-M16X130-DONUT are to be installed with chemical adhesive CON-CHEM-FISV.300. The below method is suitable for 32MPa uncracked concrete.

⚠ Check the used by date on the adhesive.

- 1 Mark the location for the hole and drill an $\text{Ø}18\text{mm}$ hole to the depth of 90mm (90mm depth must be into structural concrete). See Figure 21 for allowable edge distances.
- 2 Clean the hole, ensuring it is free of moisture and dust. Then inject the adhesive into the hole as per the manufacturer's instruction.
- 3 Insert the stud to full depth. Wipe away any adhesive expelled from the hole. The top of the stud shall sit at least 35mm from the surface of the concrete.

⚠ Ensure enough adhesive is used, the adhesive should finish flush with the concrete.

- 4 Once the adhesive is cured, place the FrogLine bracket on the stud and install the Donut washer and spring washer, tighten the nut to 60Nm. The top of the stud may be cut down to leave a minimum of 2 threads exposed.

The DonutLink can be proof loaded as per Section 4.2 with the Pull Test Adaptor (DONUTLINK-ADP) and a Hydrajaws portable tension tester.

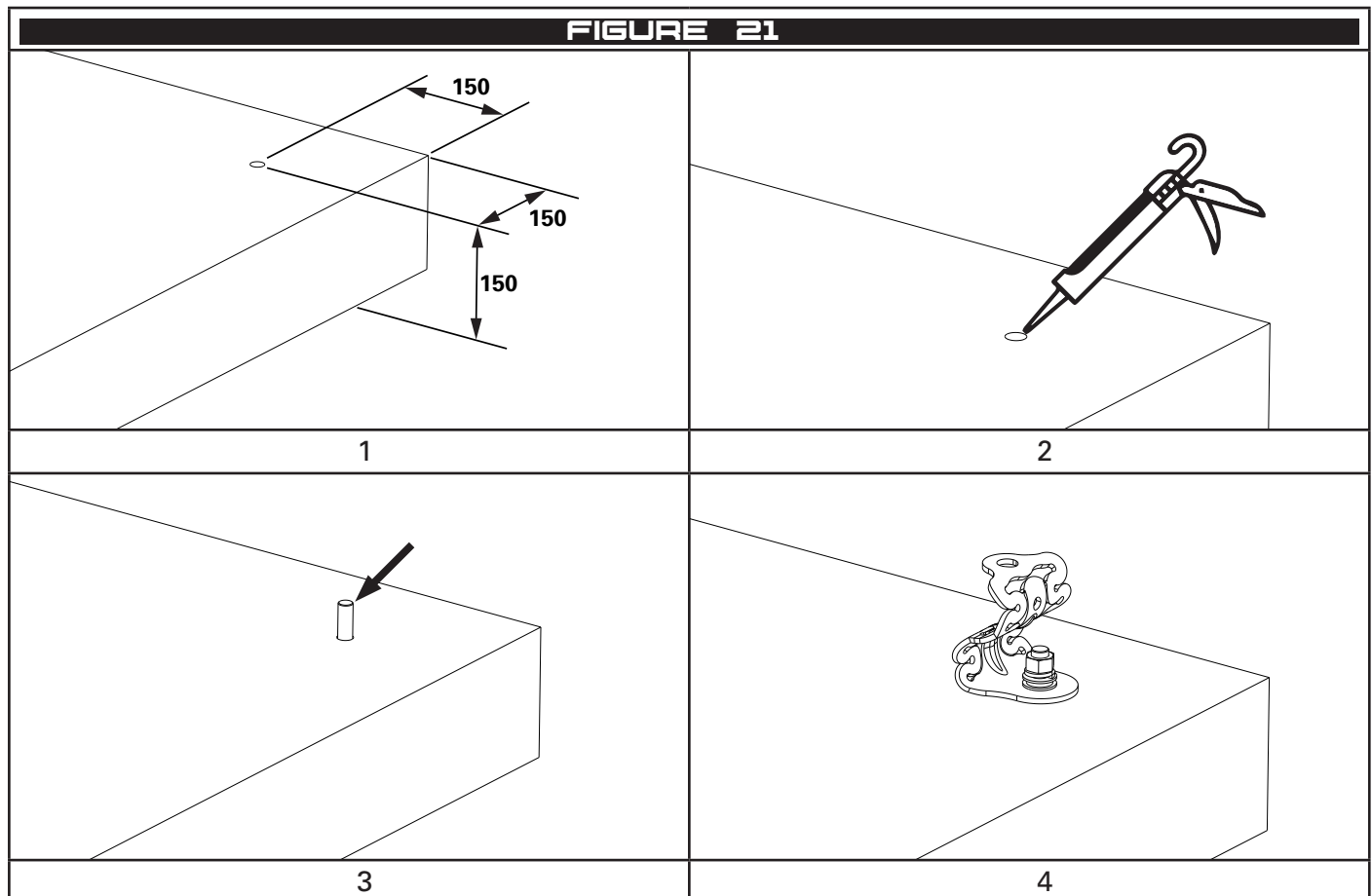

4.11.2 Concrete Studs M12

SafetyLink's DonutLink M12 Concrete Stud CON-M12X130-DONUT are to be installed with chemical adhesive CON-CHEM-FISV.300. The below method is suitable for 32MPa uncracked concrete.

⚠ Check the used by date on the adhesive.

- 1 Mark the location for the hole and drill a $\varnothing 14\text{mm}$ hole to the a depth of 90mm (90mm depth must be into structural concrete). See Figure 22 for allowable edge distances.
- 2 Clean the hole, ensuring it is free of moisture and dust. Then inject the adhesive into the hole as per the manufacturer's instruction.
- 3 Insert the stud to full depth. Wipe away any adhesive expelled from the hole. The top of the stud shall sit at least 35mm from the surface of the concrete.

⚠ Ensure enough adhesive is used, the adhesive should finish flush with the concrete.

- 4 Once the adhesive is cured, place the FrogLine bracket on the stud and install the M12-M16 bushing, spring washer and tighten the Donut to 50Nm. The top of the stud may be cut down to leave a minimum of 2 threads exposed.

The DonutLink can be proof loaded as per Section 4.2 with the Pull Test Adaptor (DONUTLINK-ADP) and a Hydrajaws portable tension tester.

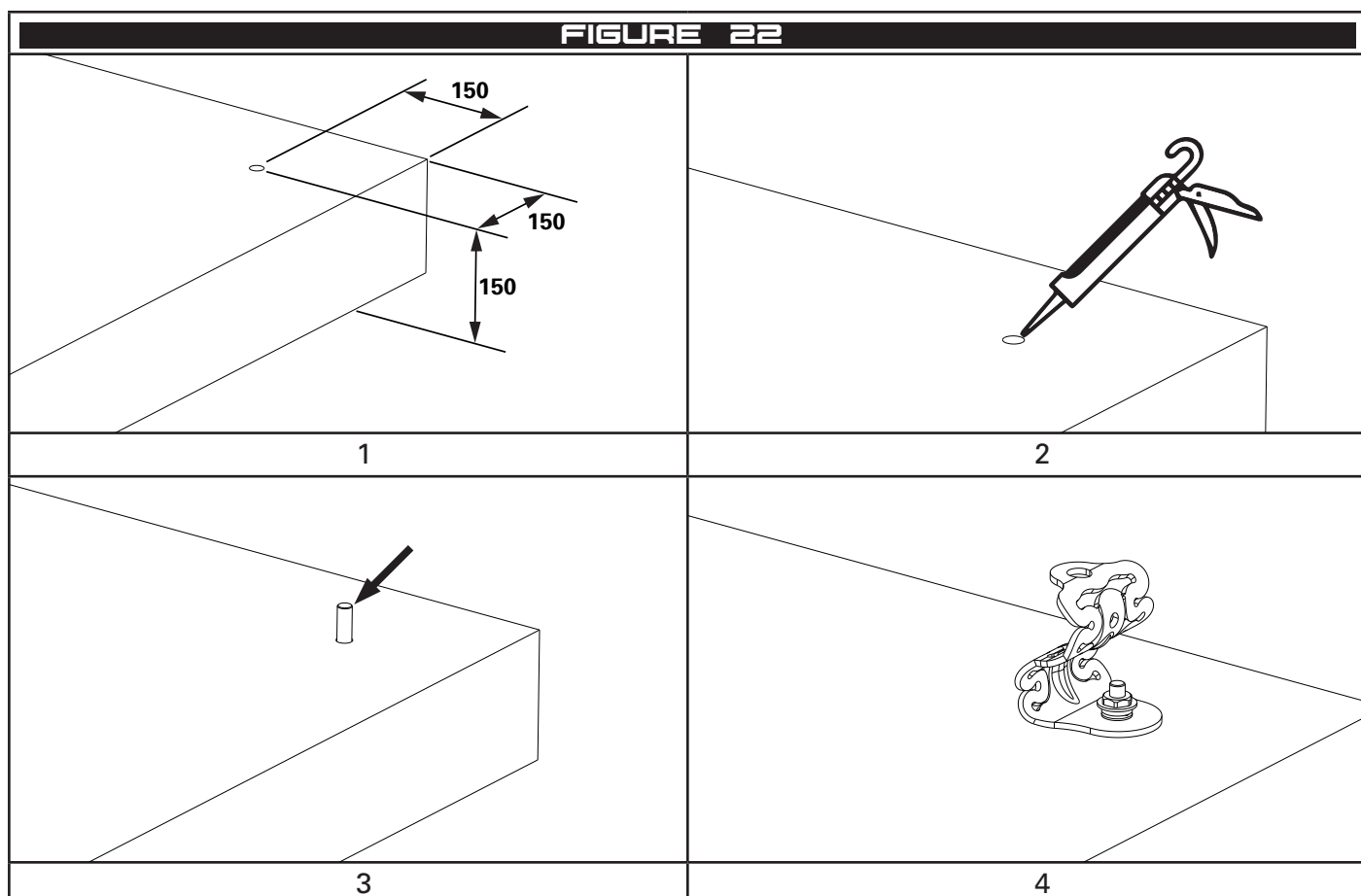

4.11.3 Concrete Inserts

SafetyLink's DonutLink M16 Concrete Insert CON-INSERT are to be installed with chemical adhesive CON-CHEM-FISV.300. The below method is suitable for 32MPa uncracked concrete.

⚠ Check the used by date on the adhesive.

- 1 Mark the location for the hole and drill a $\text{Ø}28\text{mm}$ hole to the a depth of 90mm (90mm depth must be into structural concrete). See Figure 23 for allowable edge distances.
- 2 Clean the hole, ensuring it is free of moisture and dust. Then inject the adhesive into the hole as per the manufacturer's instruction.
- 3 Install the Insert to full depth. Wipe away any adhesive expelled from the hole. The top of the insert shall sit flush with the surface of the concrete.

⚠ Ensure enough adhesive is used, the adhesive should finish flush with the concrete.

- 4 Once the adhesive is cured, place the FrogLine bracket over the socket and install the eyebolt. Tighten to 60Nm.

The DonutLink can be proof loaded as per Section 4.2 with the Pull Test Adaptor (DONUTLINK-ADP) and a Hydrajaws portable tension tester.

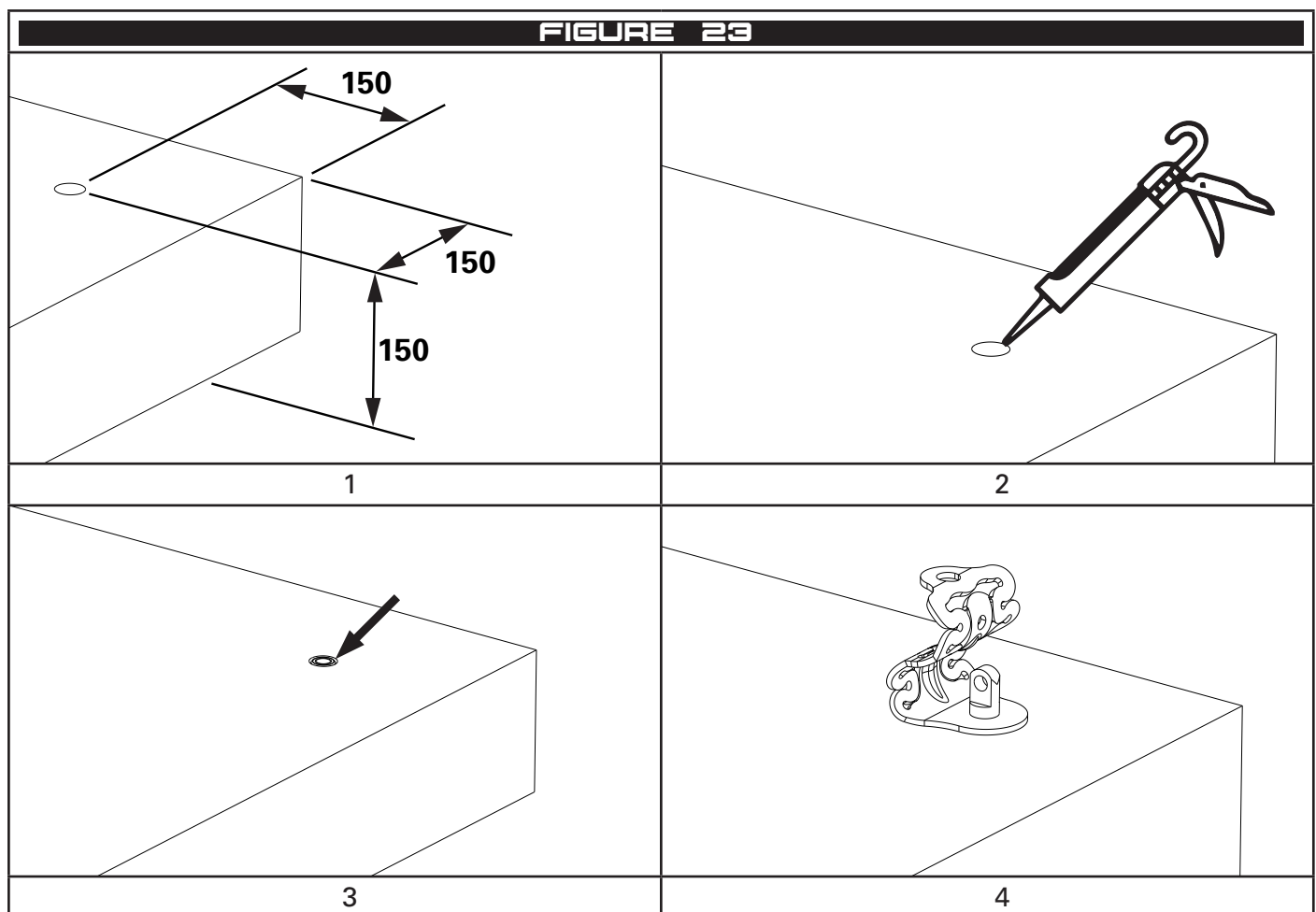

4.11.4 Tuff Post

- 1 Install the Tuff-Post as per the Tuff-Post installation handbook.
- 2 Install the bracket on top of the Tuff-Post with a DonutLink, spring washer and M16 bolt. Tighten to 60Nm.
- 3 Proof loading can be conducted from either the top of the post or directly on the stud as per Section 4.2.

✔ Donut washers are only required at the location where the proof loading is going to take place.

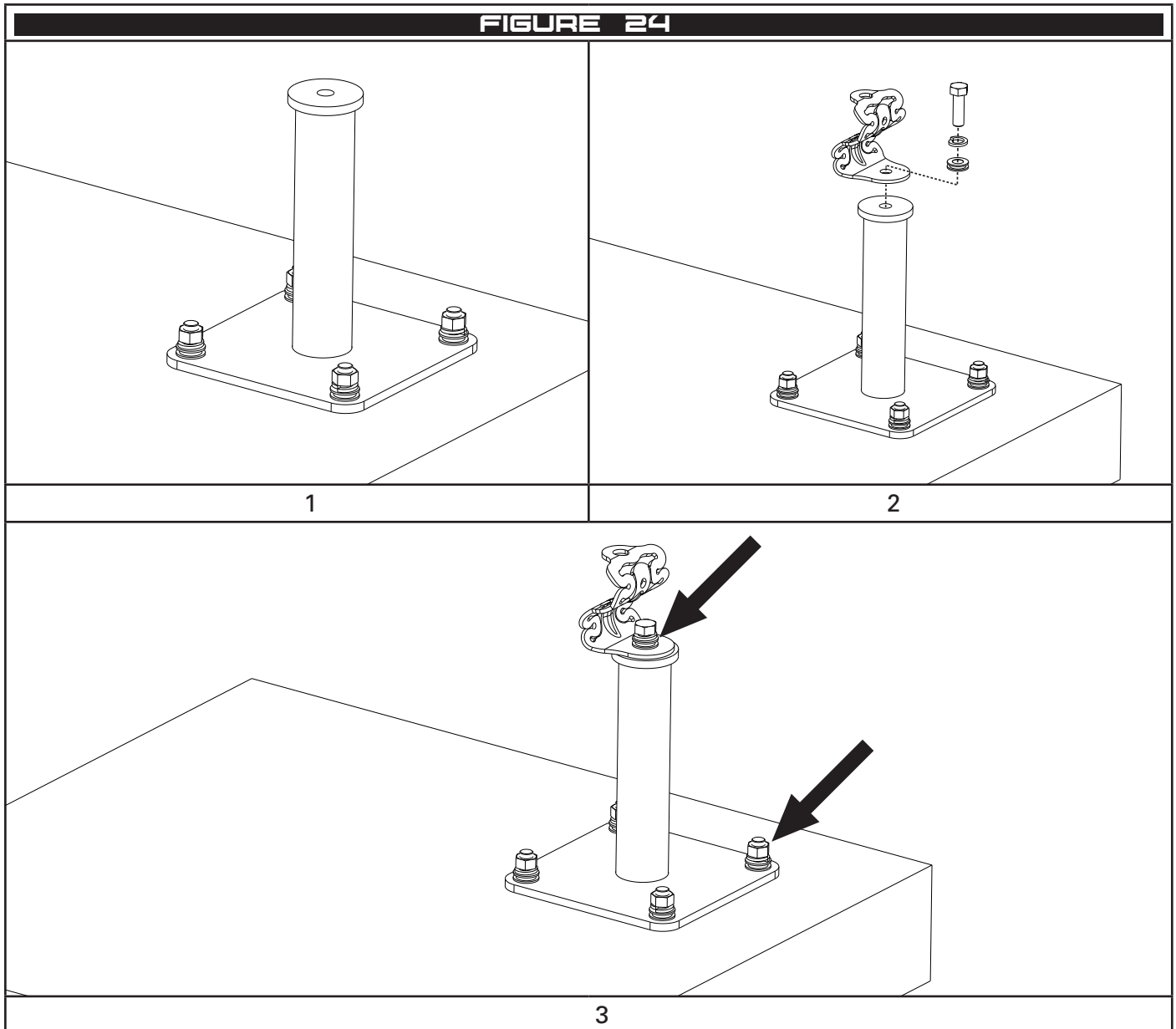

4.12 Steel

4.12.1 M16 Bolt

- 1 Drill a 18mm hole into the structure.
- 2 Fasten the bracket with a M16 hex bolt, washer, spring washer and nut. Tighten to 70Nm.

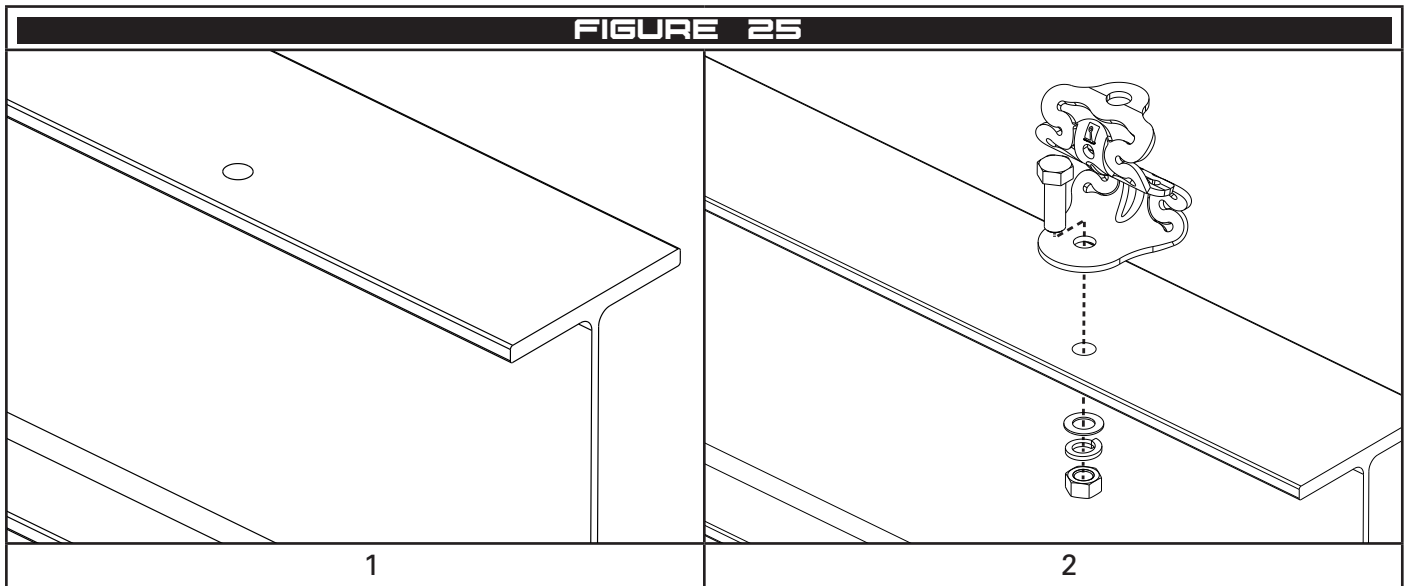

4.12.2 M12 Bolt

- 1 Drill a 14mm hole into the structure.
- 2 Fasten the bracket with a M12 hex bolt, M16-M12 bushing, washer, spring washer and nut. Tighten to 50Nm.

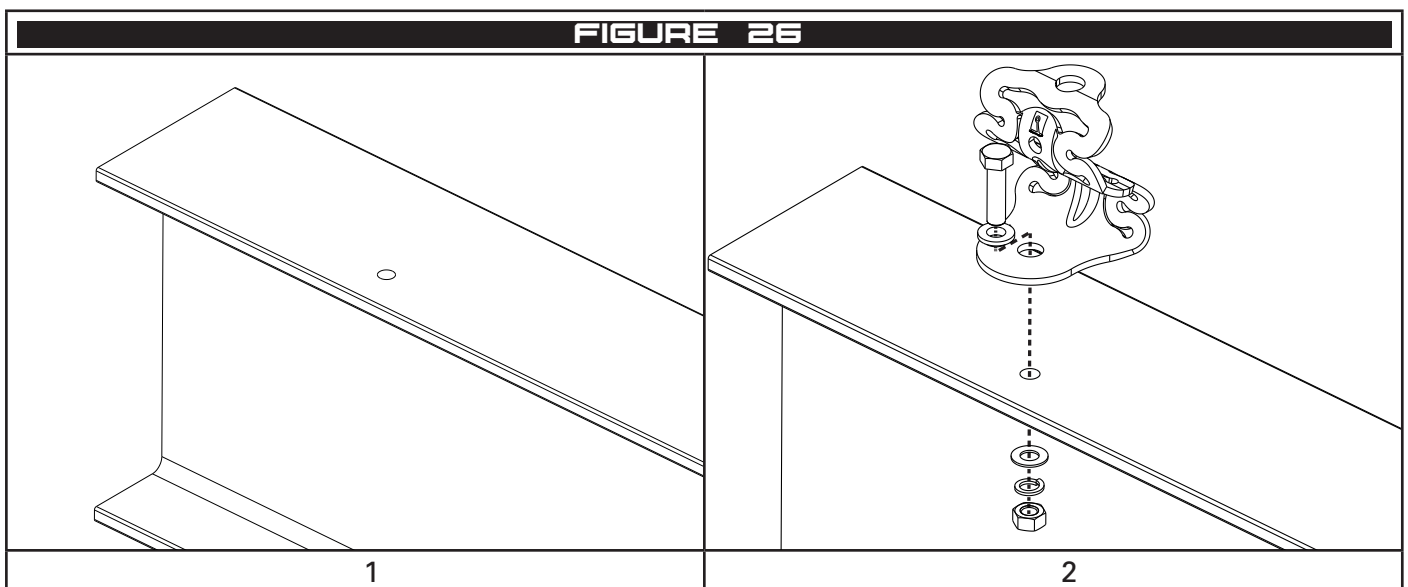

4.12.3 Tuff Post

- 1 Install the Tuff-Post as per the Tuff-Post installation handbook.
- 2 Install the bracket on top of the Tuff-Post with a washer, spring washer and M16 bolt. Tighten to 70Nm.

FIGURE 27

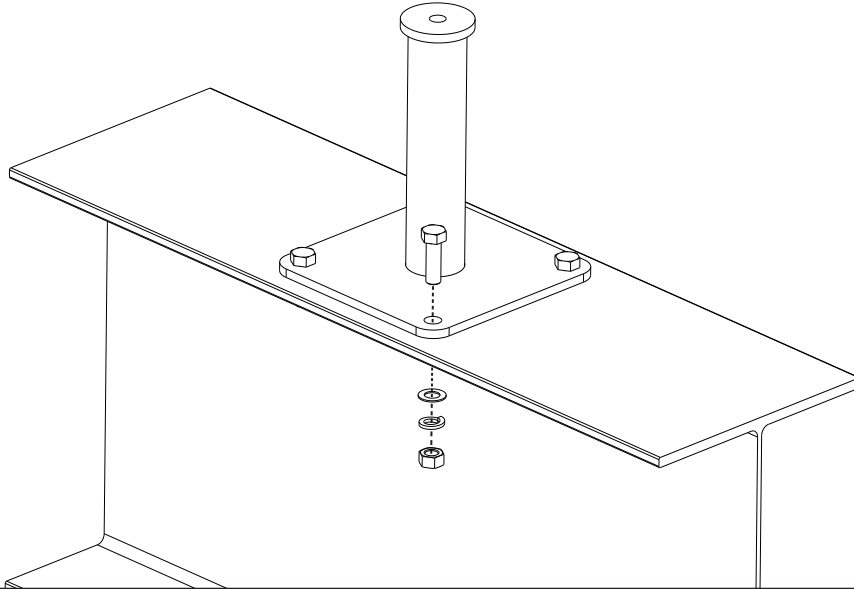

1

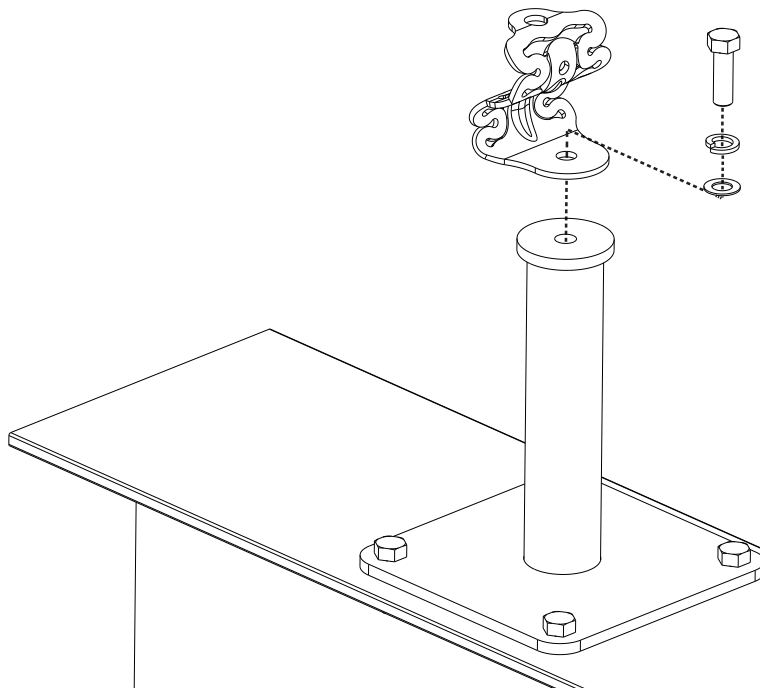

2

4.13 Core filled Blocks

⚠ *The suitability of the wall to sustain the loads in Section 3.6 shall be assessed by a trained engineer.*

- 1 Drill a 18mm hole through one of the blocks towards the centre of the cavity.
- 2 With a suitable length of M16 threaded rod, install the bracket with a nut, spring washer and flat washer on the bracket side and a nut, spring washer and 70mm OD washer on the other side.
- 3 Tighten to 60Nm.

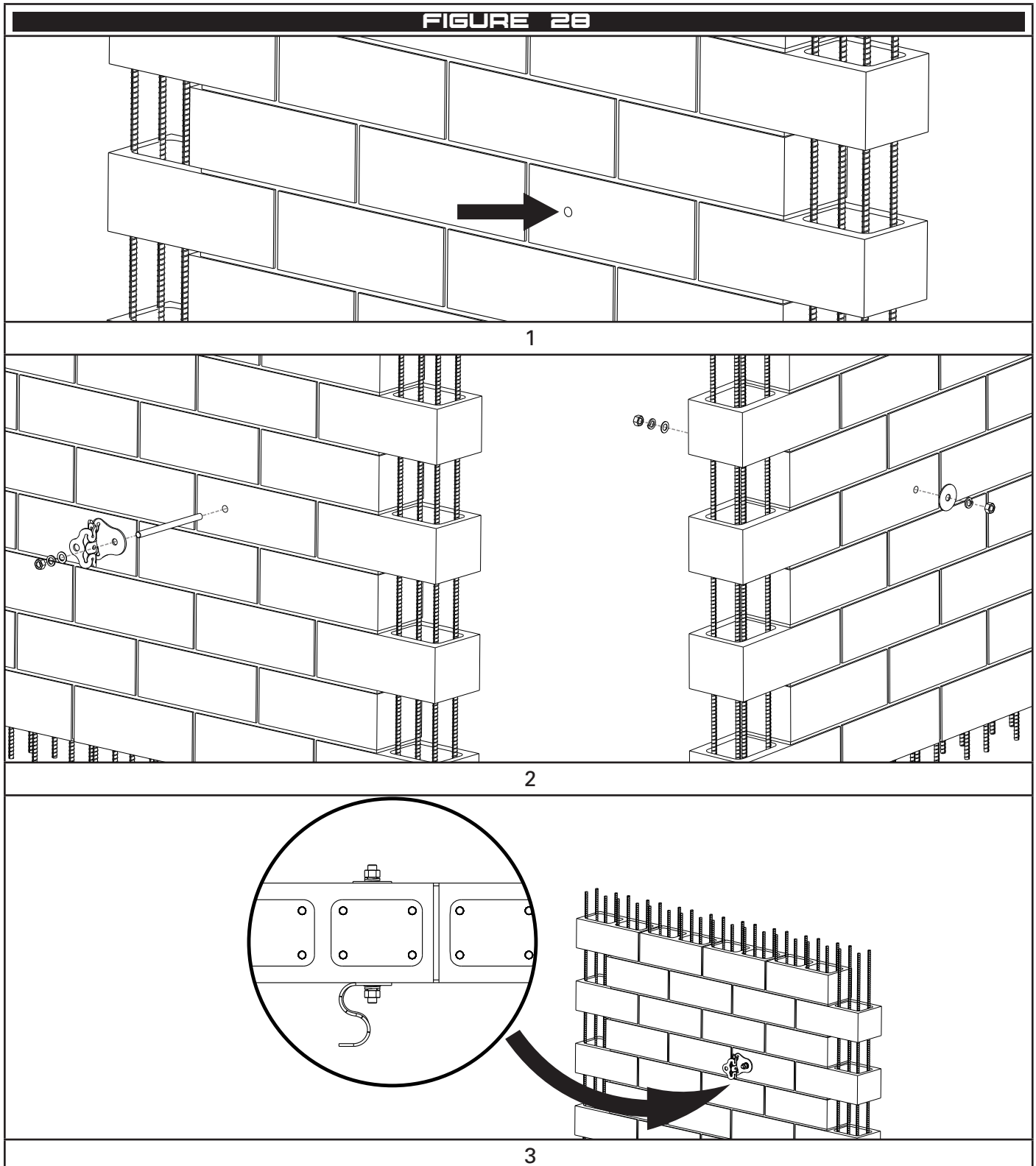

4.14 Retro

- 1 Drill a 25mm hole in the structure.
- 2 Pass the Retro Tube through the structure.
- 3 Install the foam washer on the surface where the bracket or extension will sit.
- 4 Apply silicone to the base of the bracket or extension and install with a 90mm hex bolt. For extension installations, silicone should be applied to the inside of the extension.

! *When installed with an extension, a longer bolt is required. The bolt shall be extended through the Retro Tube, with at least two threads on the other side.*

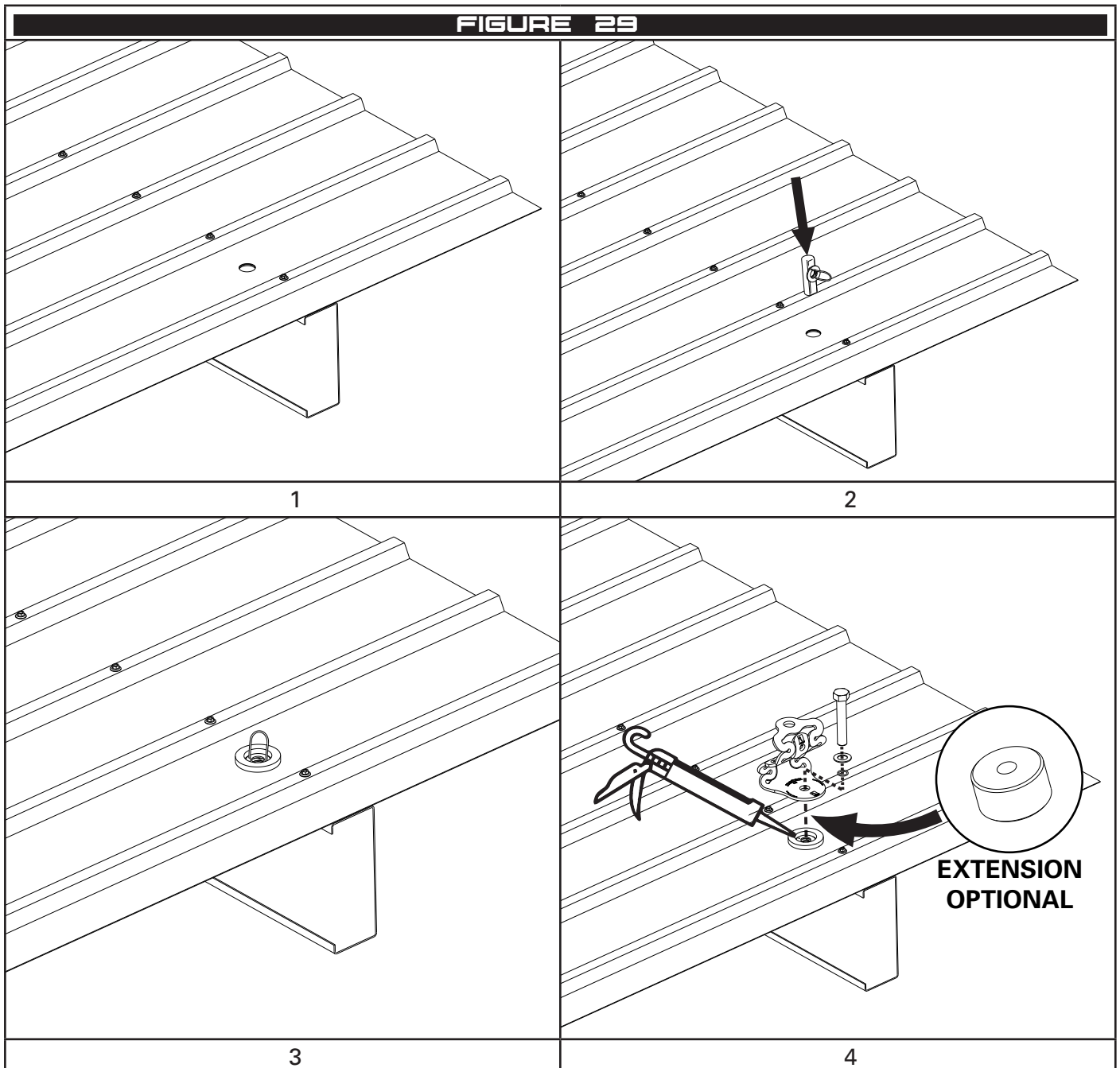

4.15 Overhead Purlin (RafterLink)

⚠ *Ends, corners and extended intermediates shall be directly mounted to the purlin and shall not use the suspension installation method 4.15.2.*

4.15.1 Direct to Purlin

- 1 Mark and drill holes equivalent to the RafterLink Base Plate in the centre of the purlin.
- 2 Place the RafterLink Base Plate inside the purlin and fix with 8 rivets.
- 3 Install the bracket with a 35mm M16 bolt and 70mm OD washer below the purlin and an M16 washer, spring washer and nut above the RafterLink Base Plate.

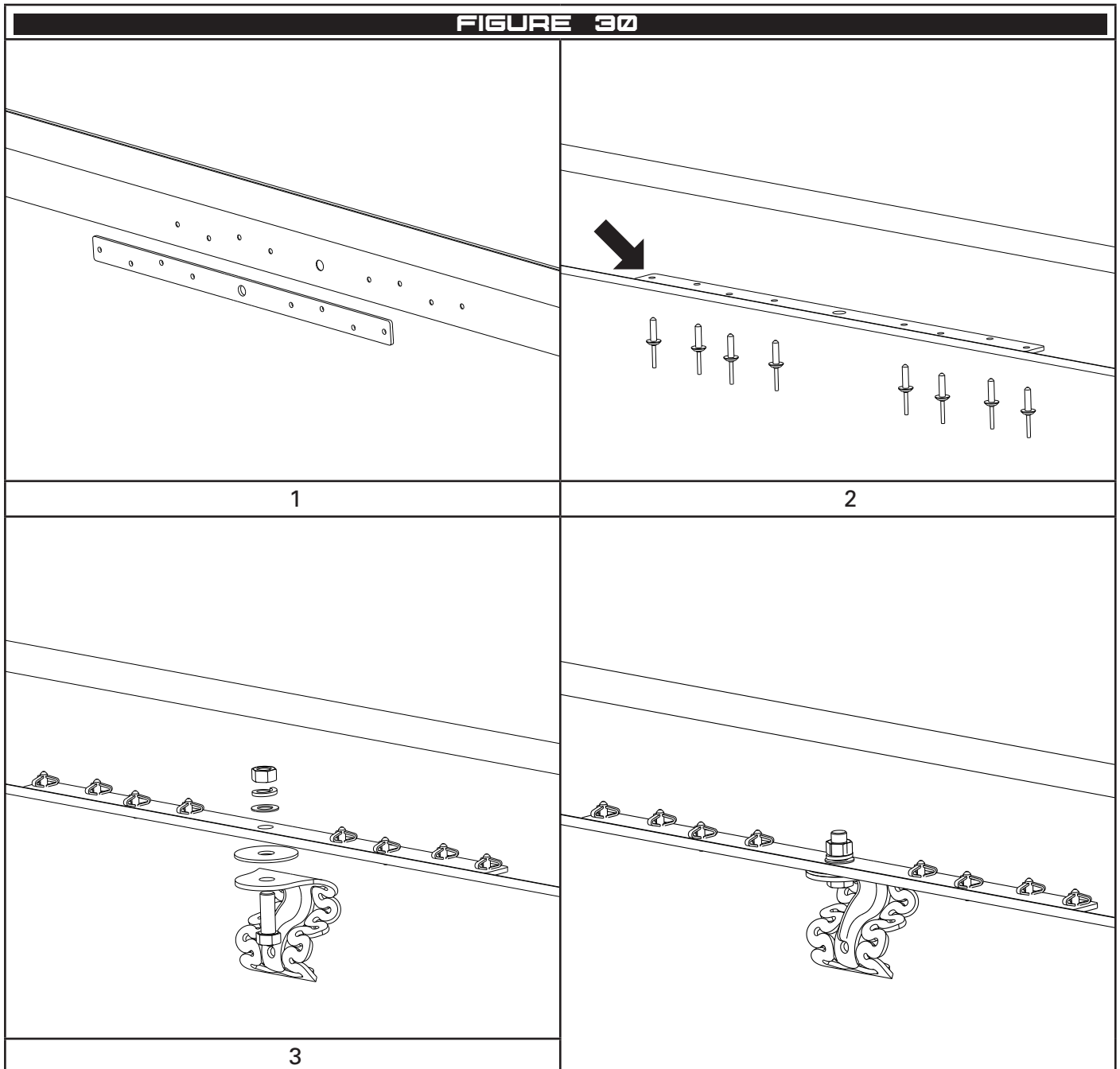

4.15.2 Suspended from Purlin

⚠ This method shall be used for regular overhead intermediates.

⚠ Threaded rod length shall not exceed 1m.

- 1 Mark and drill holes equivalent to the RafterLink Base Plate in the centre of the purlin.
- 2 Place the RafterLink Base Plate inside the purlin and fix with 8 rivets.
- 3 Install the threaded rod with an M16 nut and 70mm OD washer below the purlin and an M16 washer, spring washer and nut above the RafterLink Base Plate.
- 4 Install the intermediate bracket on the other end of the threaded rod with an M16 nut above the bracket and an M16 washer, spring washer and nut below.

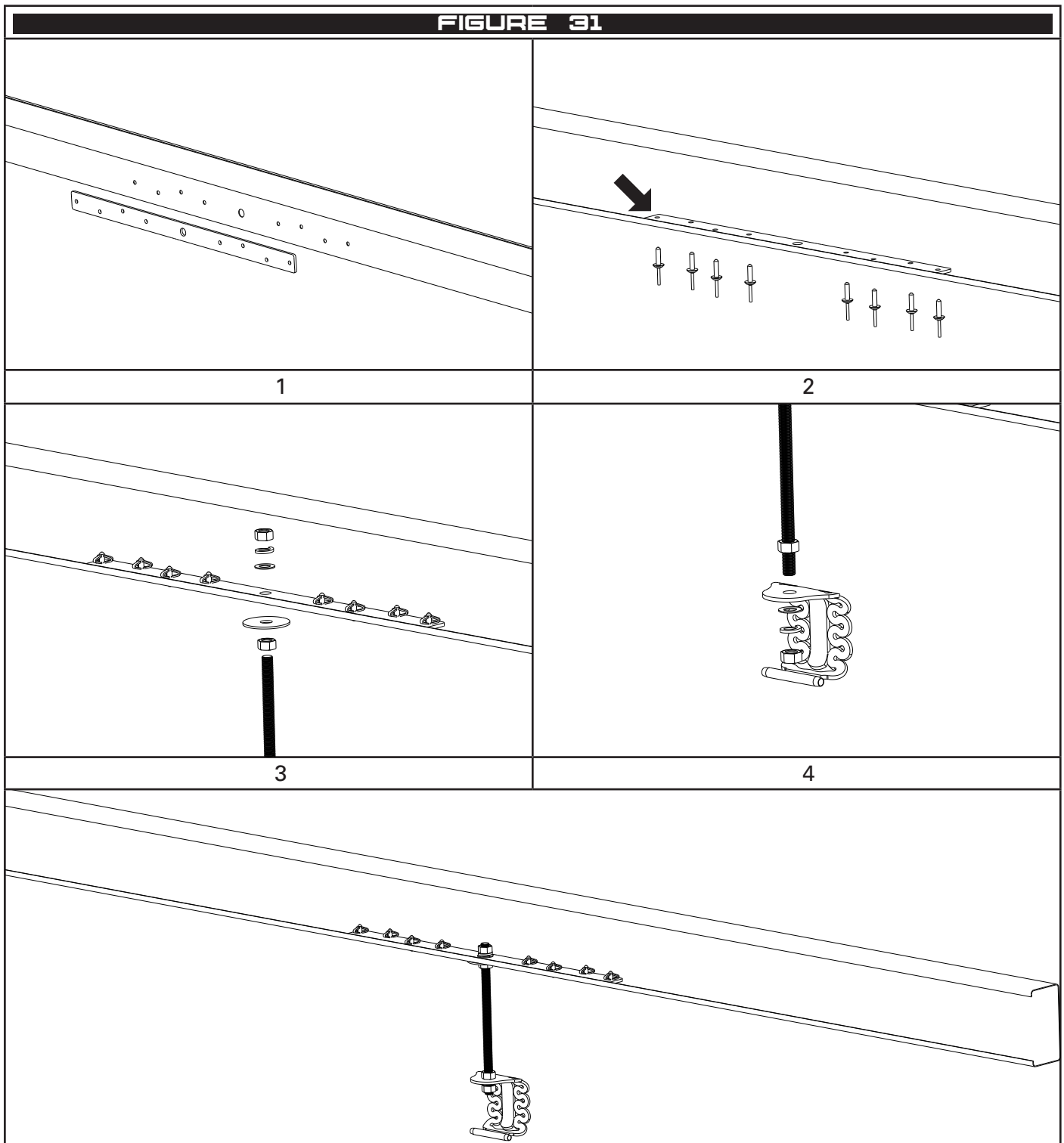

4.16 Surface

4.16.1 General

All fasteners shall be as per Section 4.1 unless stated otherwise.

All fasteners shall be installed in the location shown either through the FrogLine plate or into the structure.

Only ever install rivets or screws into a lap joint of two sheets if the rivets or screws penetrate both sheets.

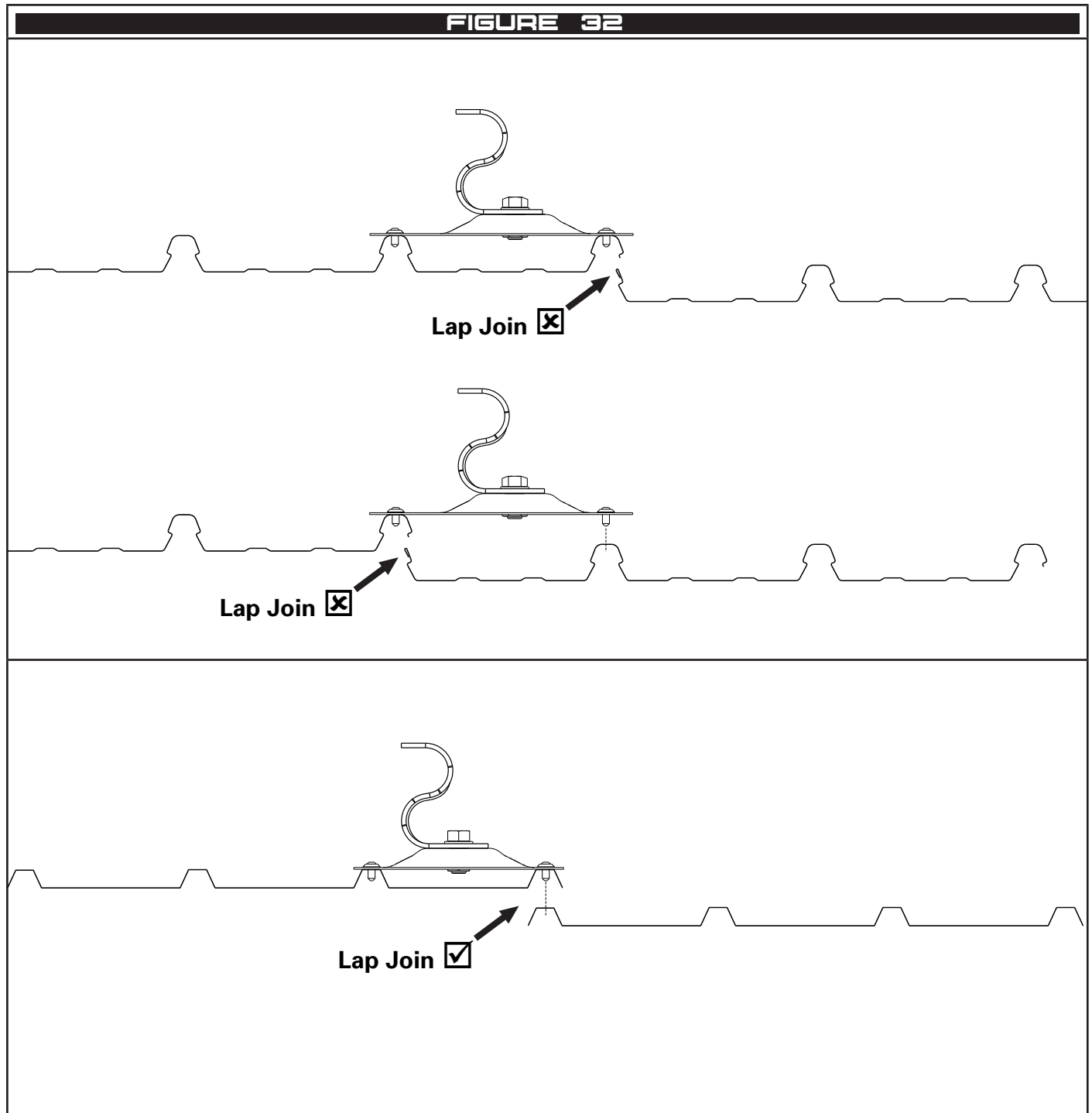

4.16.2 Plate Assembly

- 1 Apply the waterproofing strips to all screw or riveting locations that will be used for installation.
- 2 Assemble the bracket on the plate with the supplied 35mm M16 bolt placing a plastic washer on each side of the plate. (For aluminium plates only)
- 3 Install the 70mm stainless washer, spring washer and nut. Tighten to 60Nm.

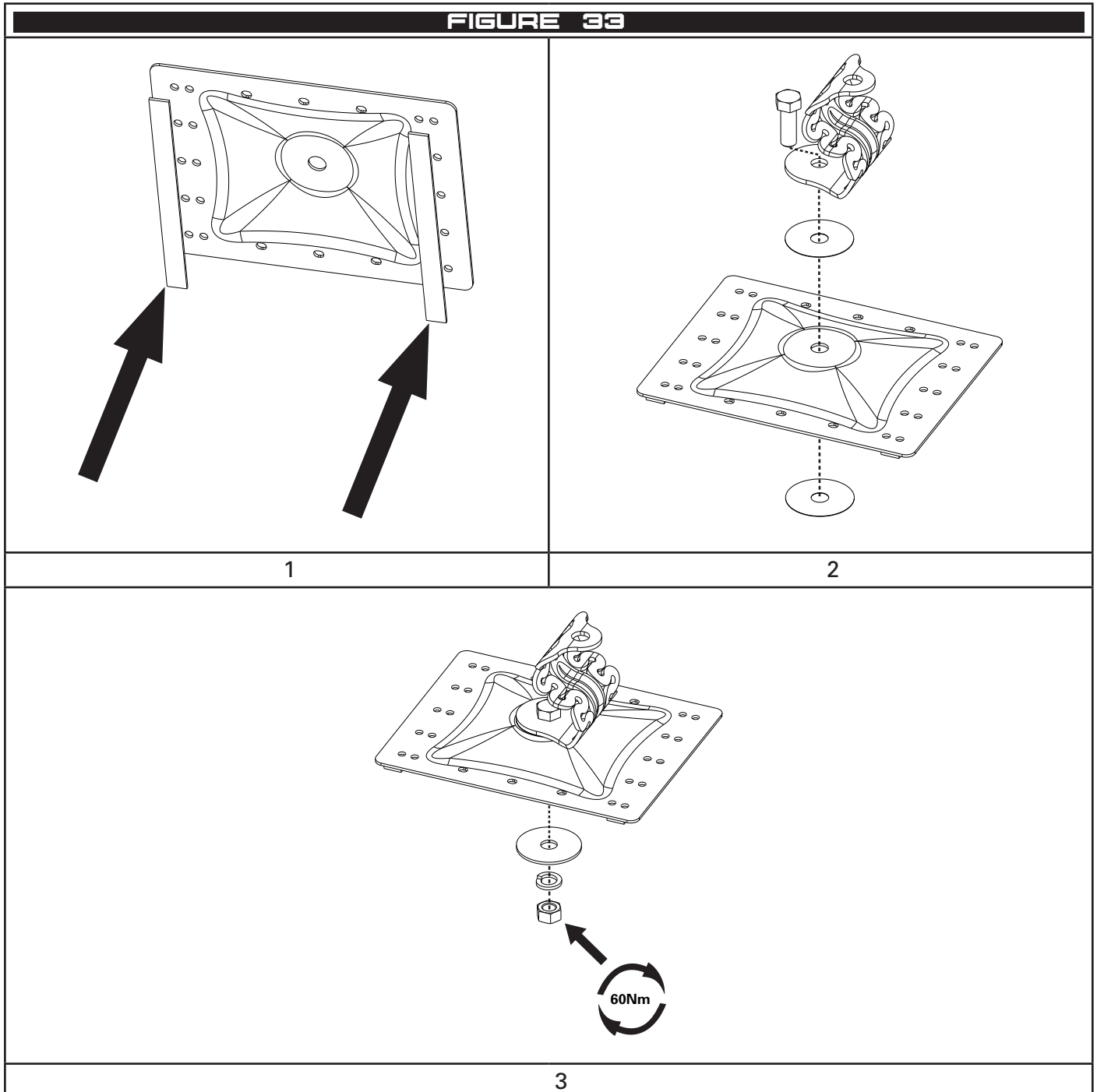

4.16.3 Screw Down Profiles (Trimdek, Custom Orb etc.)

- A For roof sheeting that is screwed to the structure, the plate may be installed anywhere on the roof sheet with 10 rivets, provided there is a screw line above and below the plate. No additional fasteners are required into the structure.
- B The plate may also be installed on the screw line with the centre two rivets being replaced by screws.

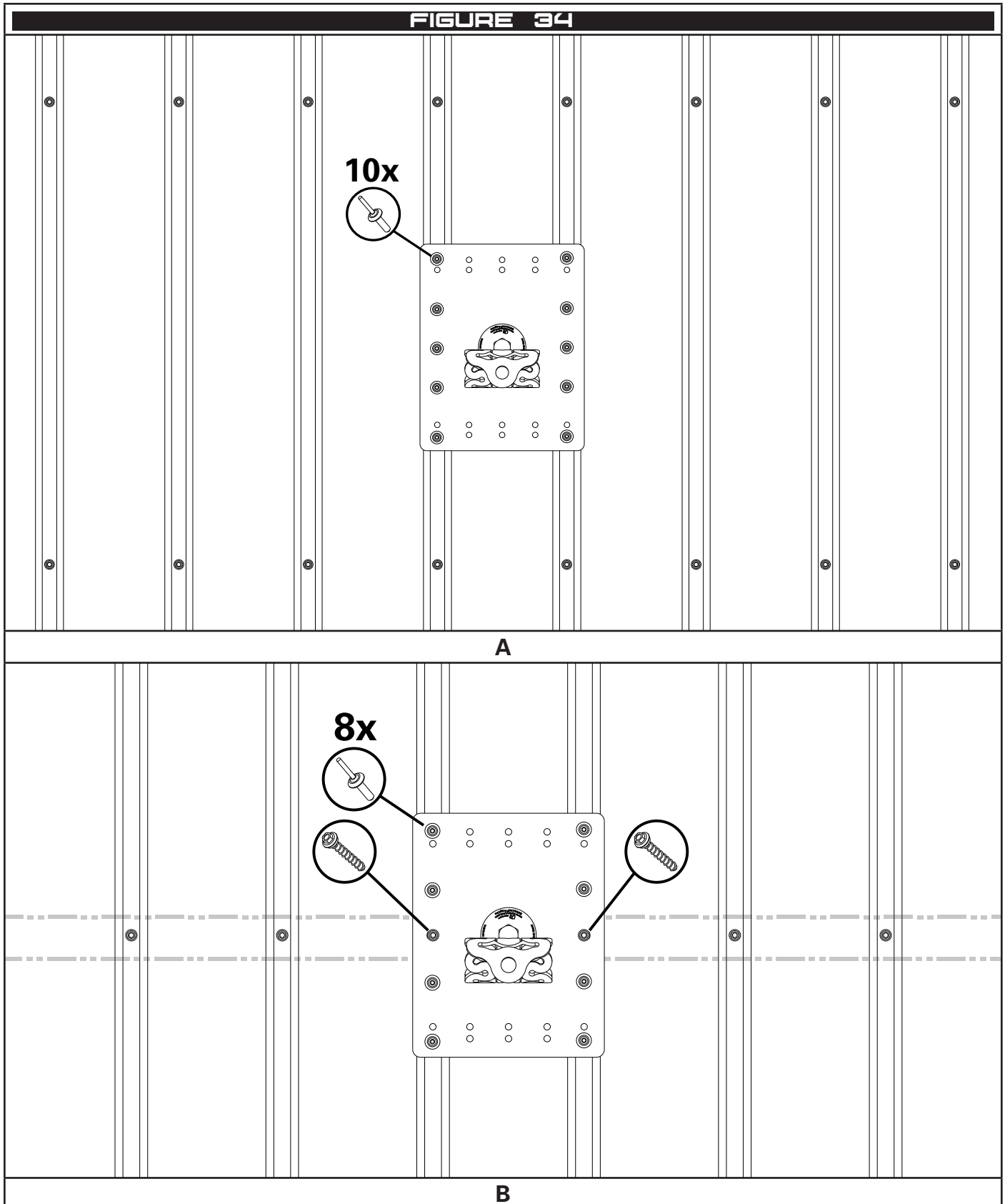

4.16.4 Clipping Profile (Kliplok Speedek Ultra, Standing Seam, KingZip etc.)

⚠ Check for lap joins.

- A If the plate is to be installed more than 2m from any edge, the plate can be installed with 10 rivets. No additional fasteners are required into the structure.
- B If the plate is to be installed within 2m of an edge, the plate can be installed with 8 rivets and 2 screws through the centre holes in the plate into a purlin.
- C If the plate is to be installed within 2m of an edge, four fixings shall be installed through the sheet that the plate is on, into the structure, between the plate and the edge. This must be done for each edge within 2m of the plate. The four fixings can be;
- I Screws through the crest of the sheet
 - II Screws in the pan of the sheet
 - III Rivets in the pan of the sheet
- D If the plate is to be installed within 2m of an edge, four fixings shall be installed through the sheet that the plate is on, into the structure, two above and two below the plate.
- E If the plate is to be installed within 2m of ridge capping or flashing, this can be assessed by a competent person to determine suitable strength as a substitute to additional securing fixings. The assessment shall include if the capping is sufficiently fastened to the roof sheeting.

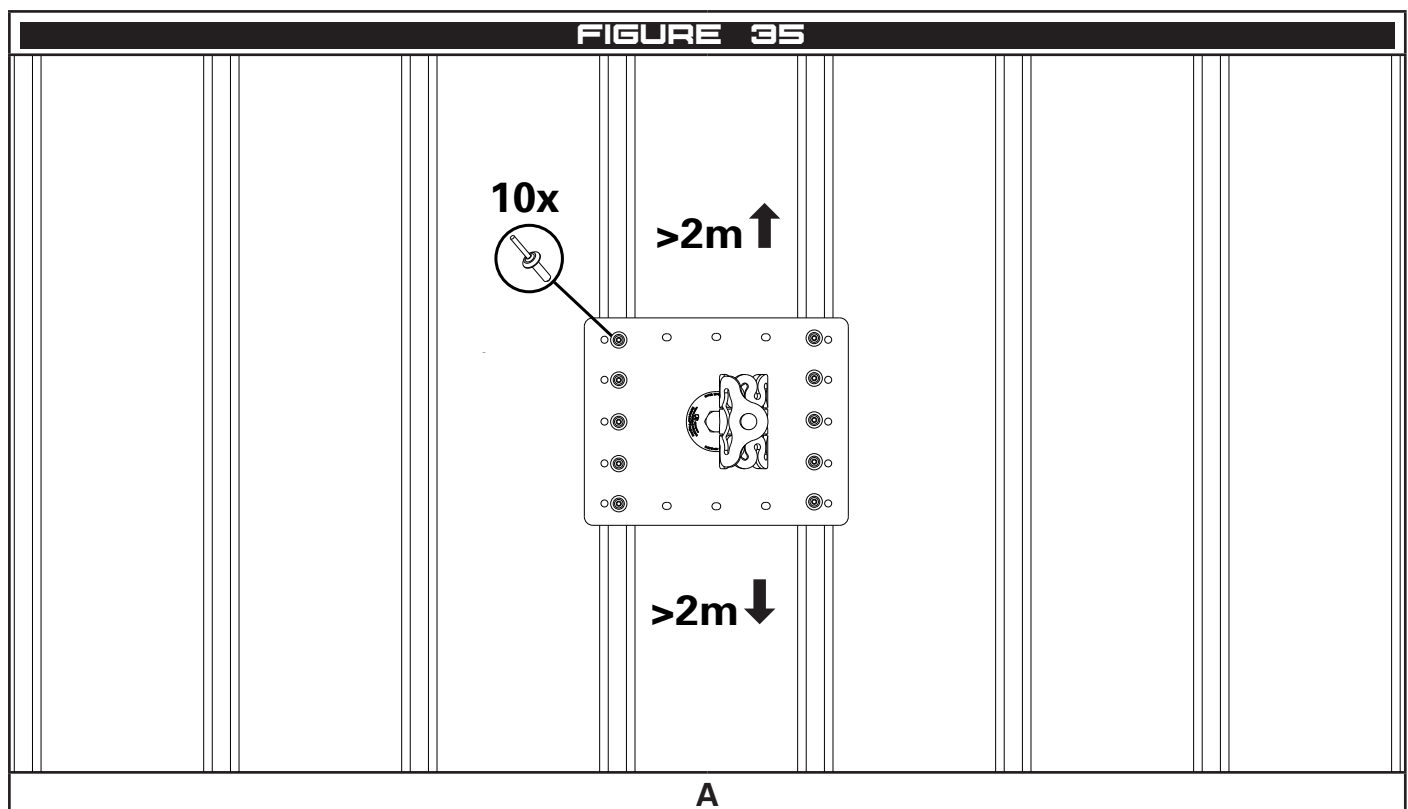

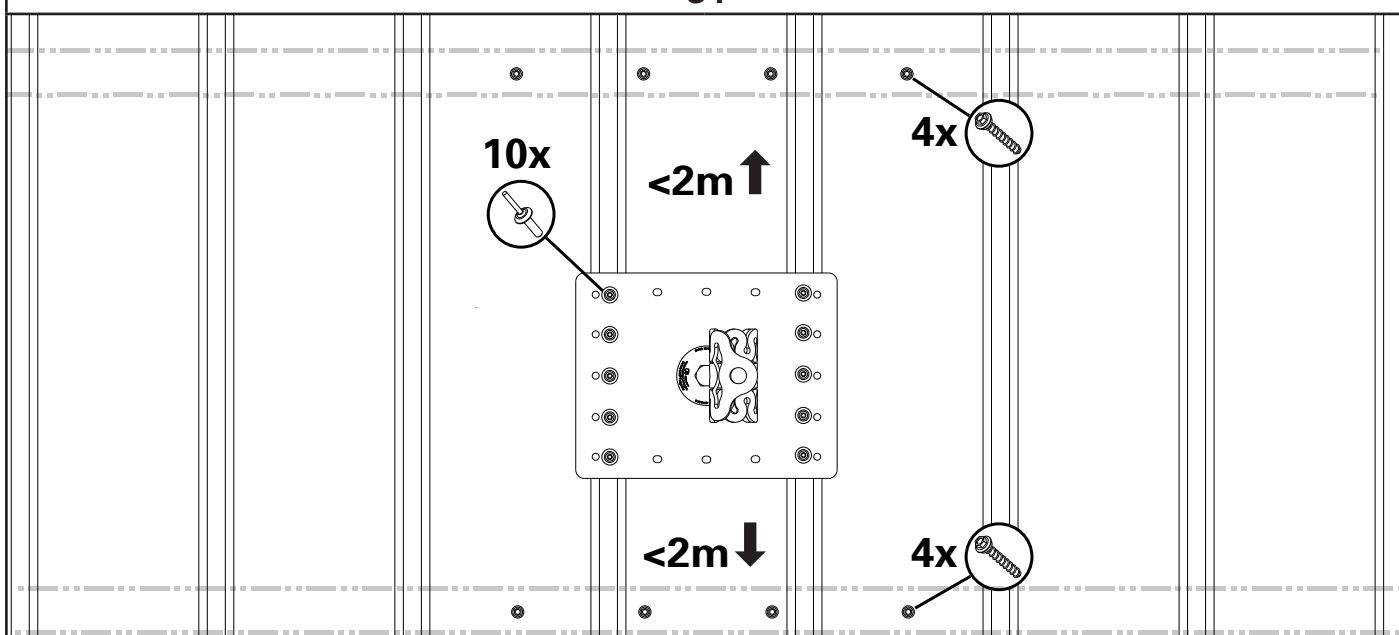
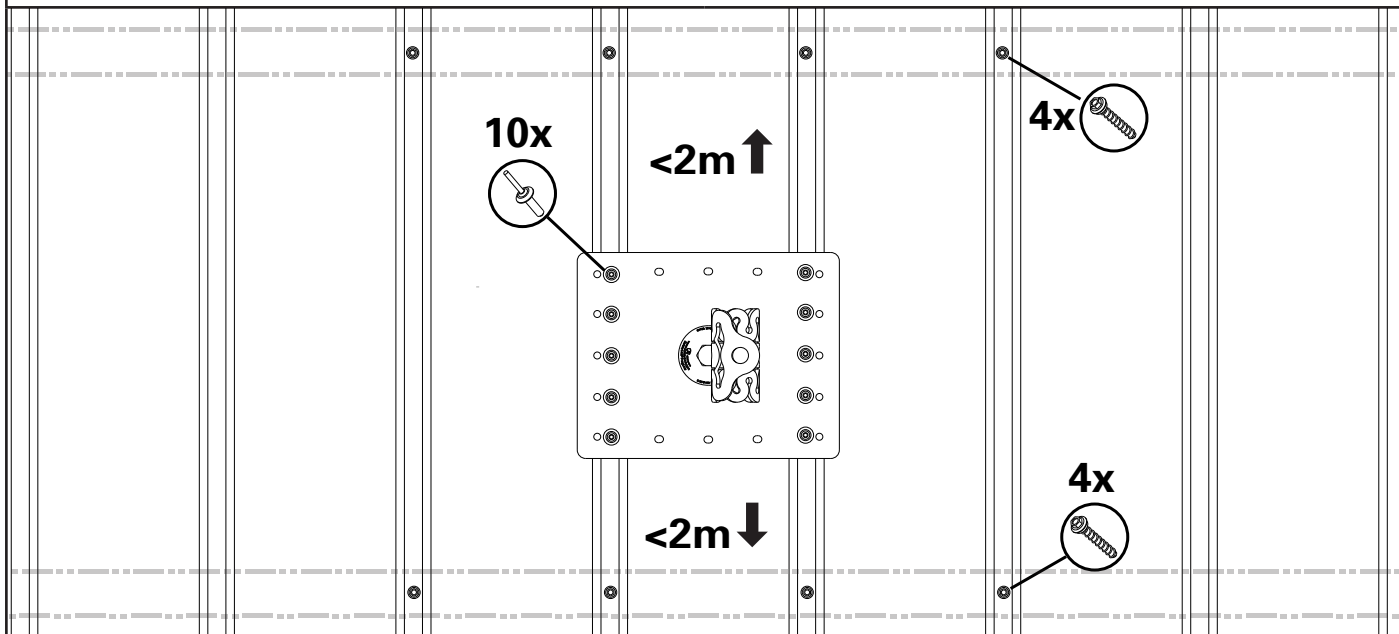
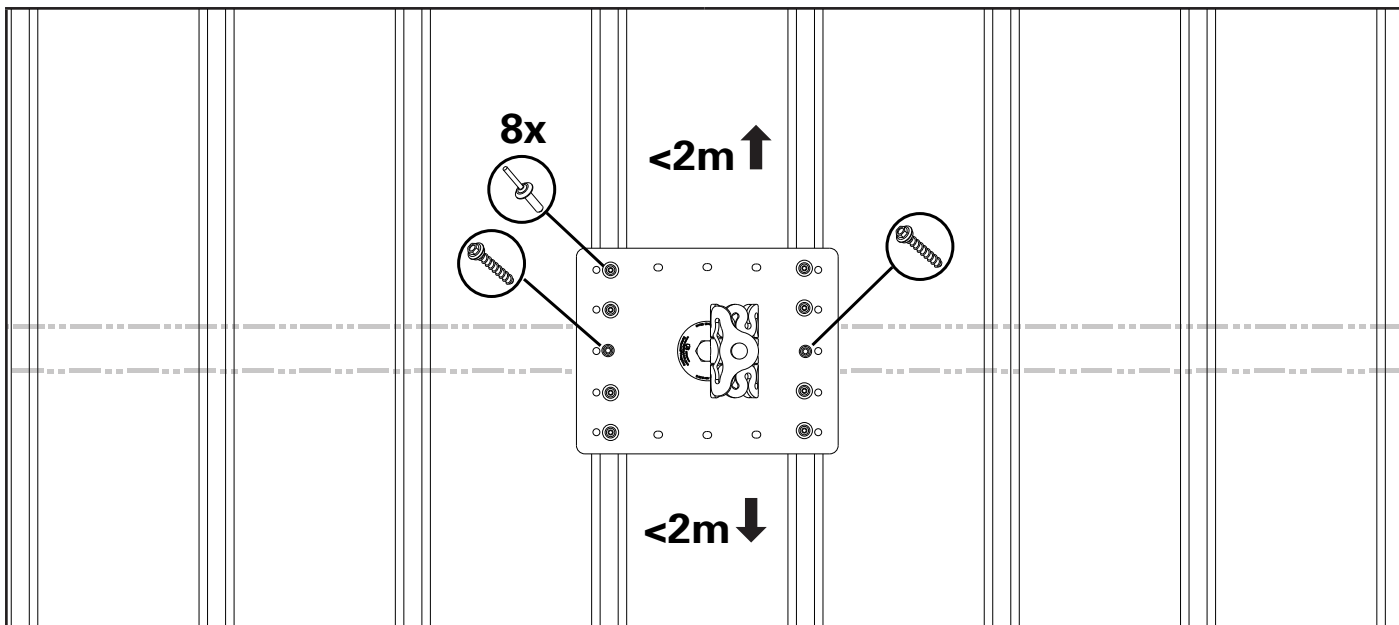

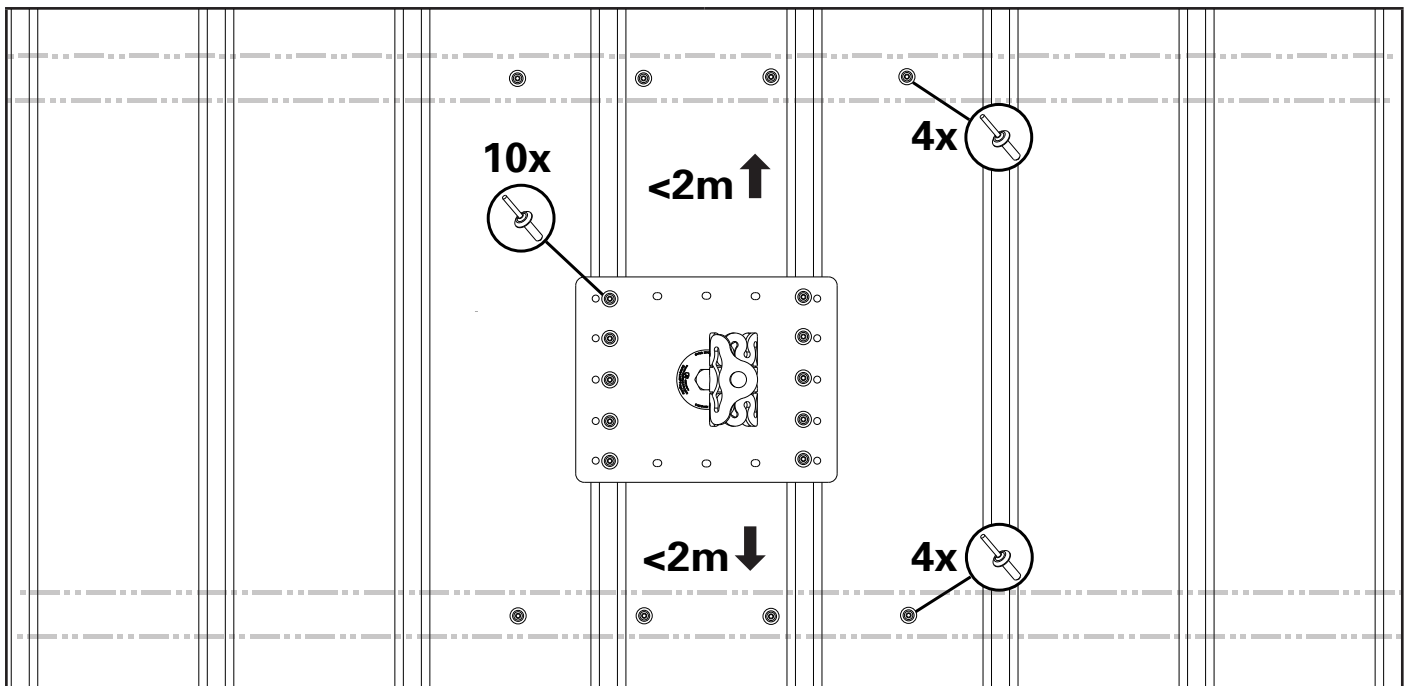

C III

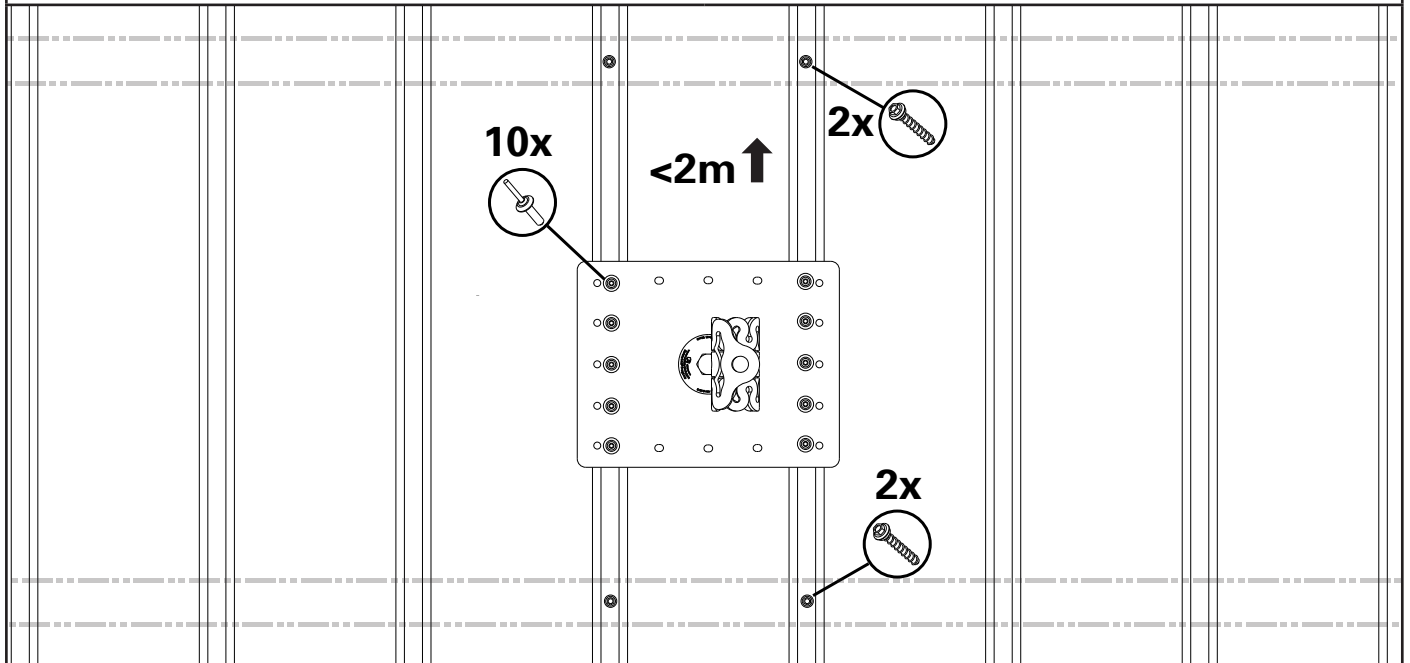

D

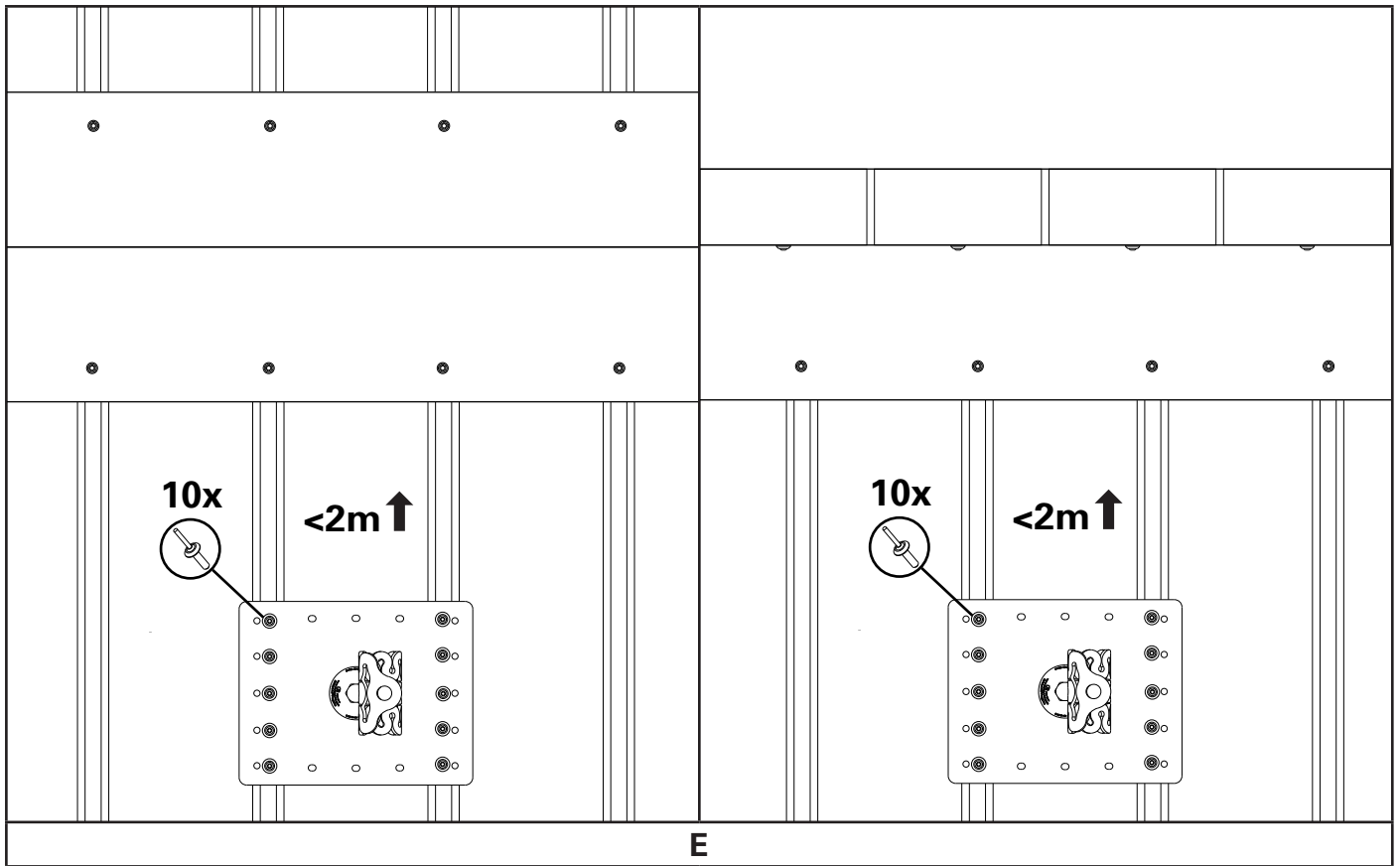

4.16.5 Raised Plates

- A If the plate is to be installed more than 2m from any edge, the plate can be installed with 10 rivets. No additional fasteners are required into the structure.
- B If the plate is to be installed within 2m of an edge, the plate can be installed with 8 rivets and 2 screws through the centre holes in the plate into a purlin.
- C If the plate is to be installed within 2m of an edge, four fixings shall be installed through the sheet that the plate is on, into the structure, between the plate and the edge. This must be done for each edge within 2m of the plate. The four fixings can be;
- I Screws through the crest of the sheet
 - II Screws in the pan of the sheet
 - III Rivets in the pan of the sheet

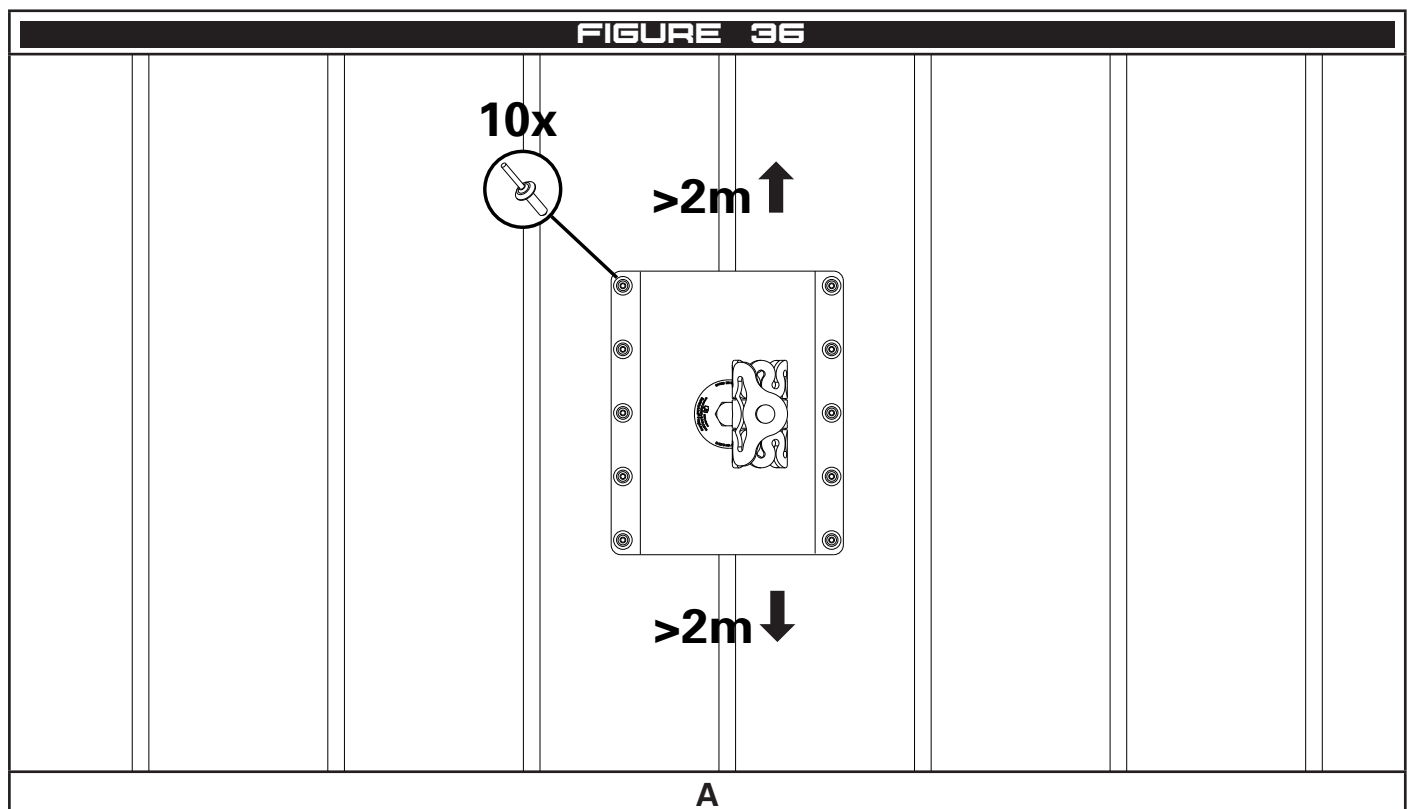

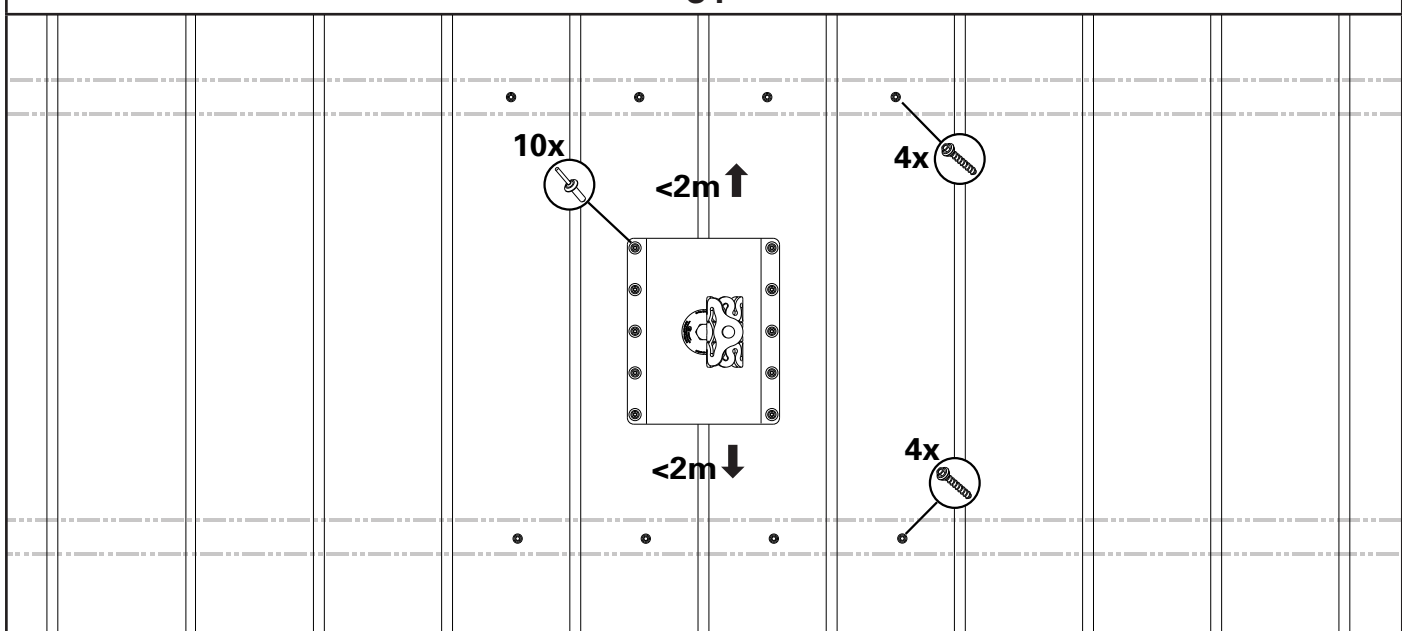
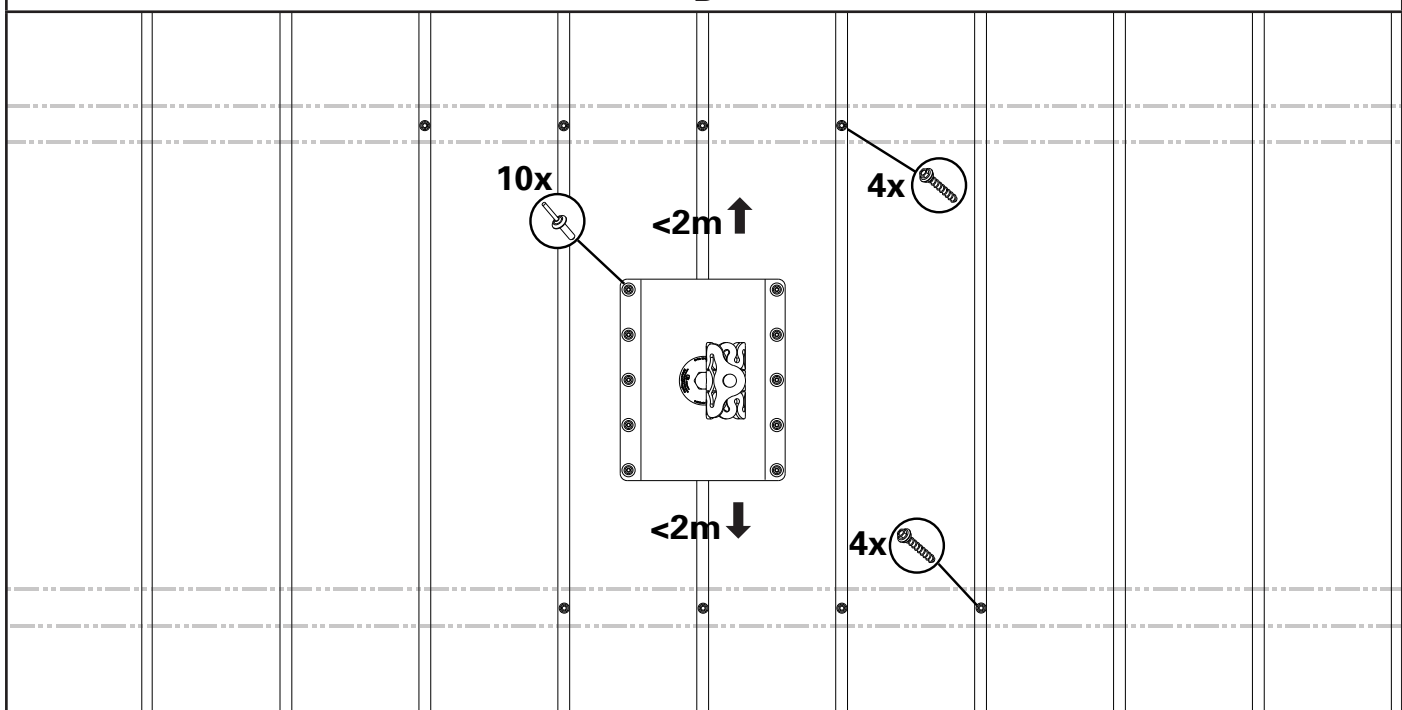
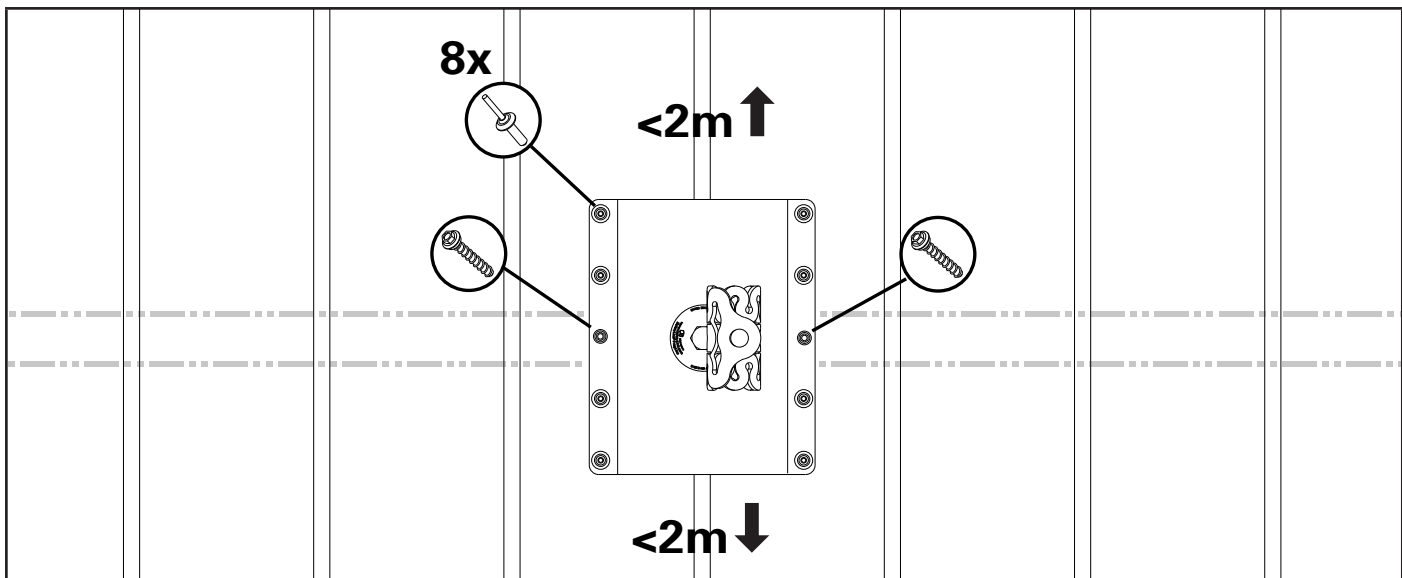

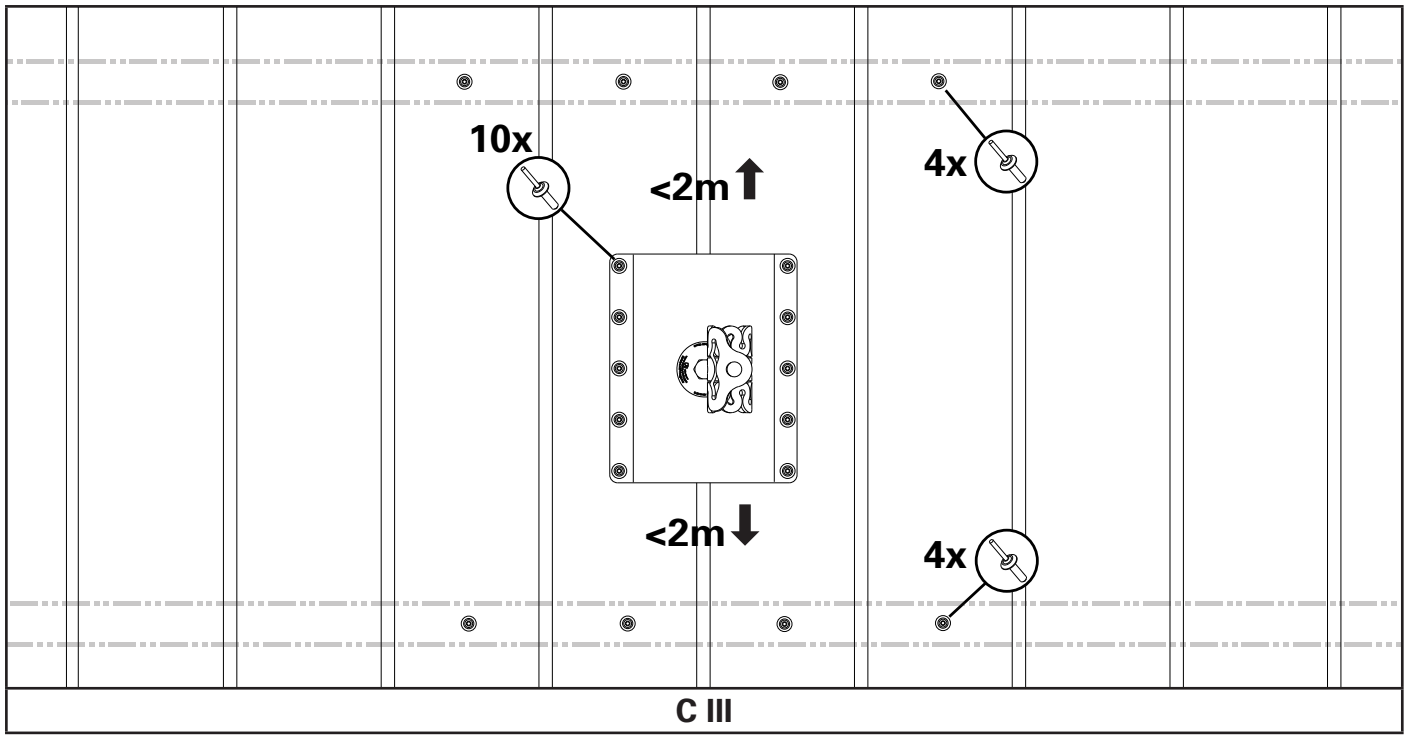

4.16.6 MaxLine

- A If the plate is to be installed more than 2m from any edge, the plate can be installed with 10 rivets and eight 10x16mm screws through the adjacent crests as shown.
- B If the plate is to be installed within 2m of an edge, four fixings shall be installed through the sheeting as shown. This must be done for each edge within 2m of the plate.
- C If the plate is to be installed within 2m of an edge, the plate can be installed with 8 rivets and 2 screws through the centre holes in the plate.

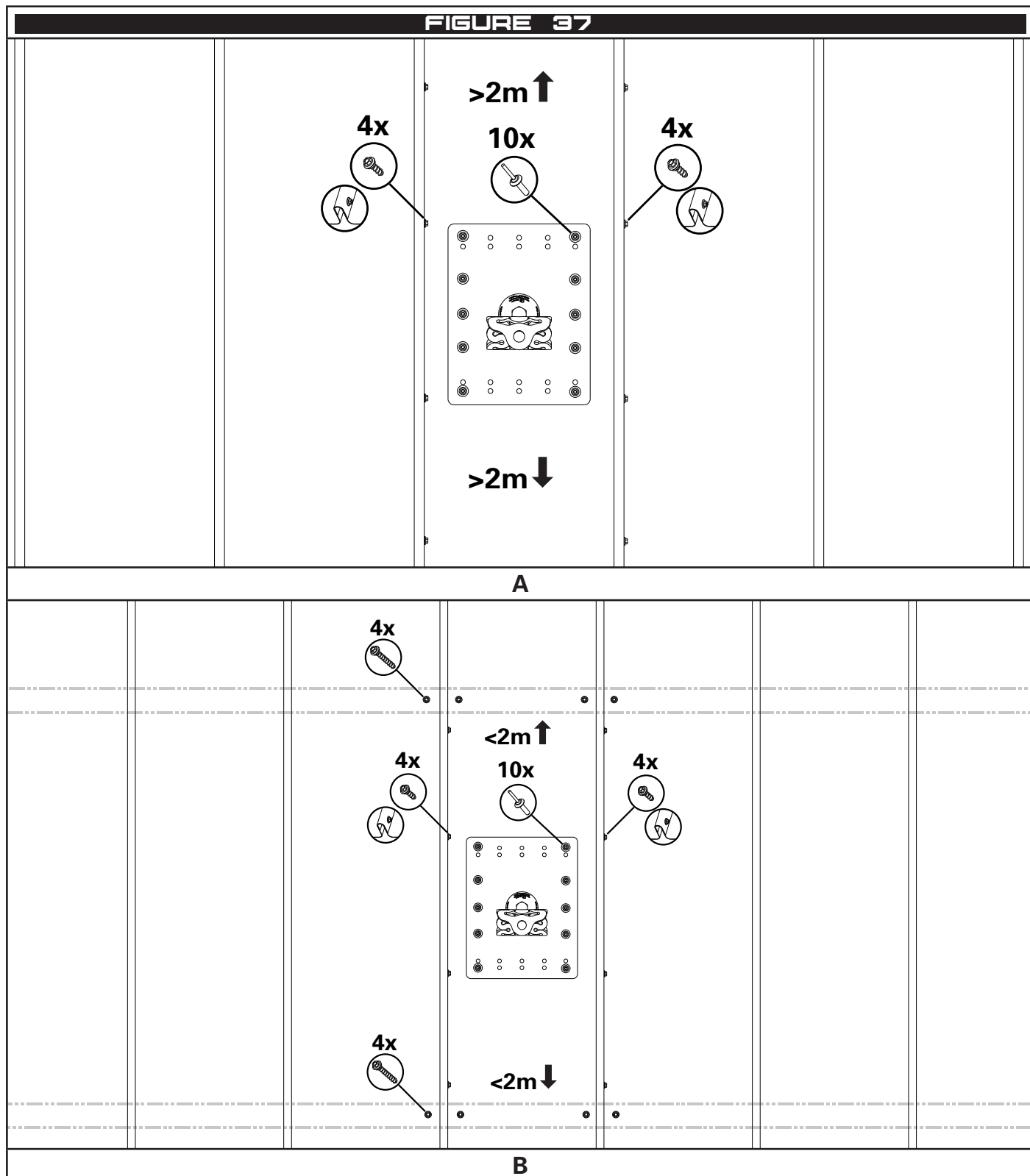

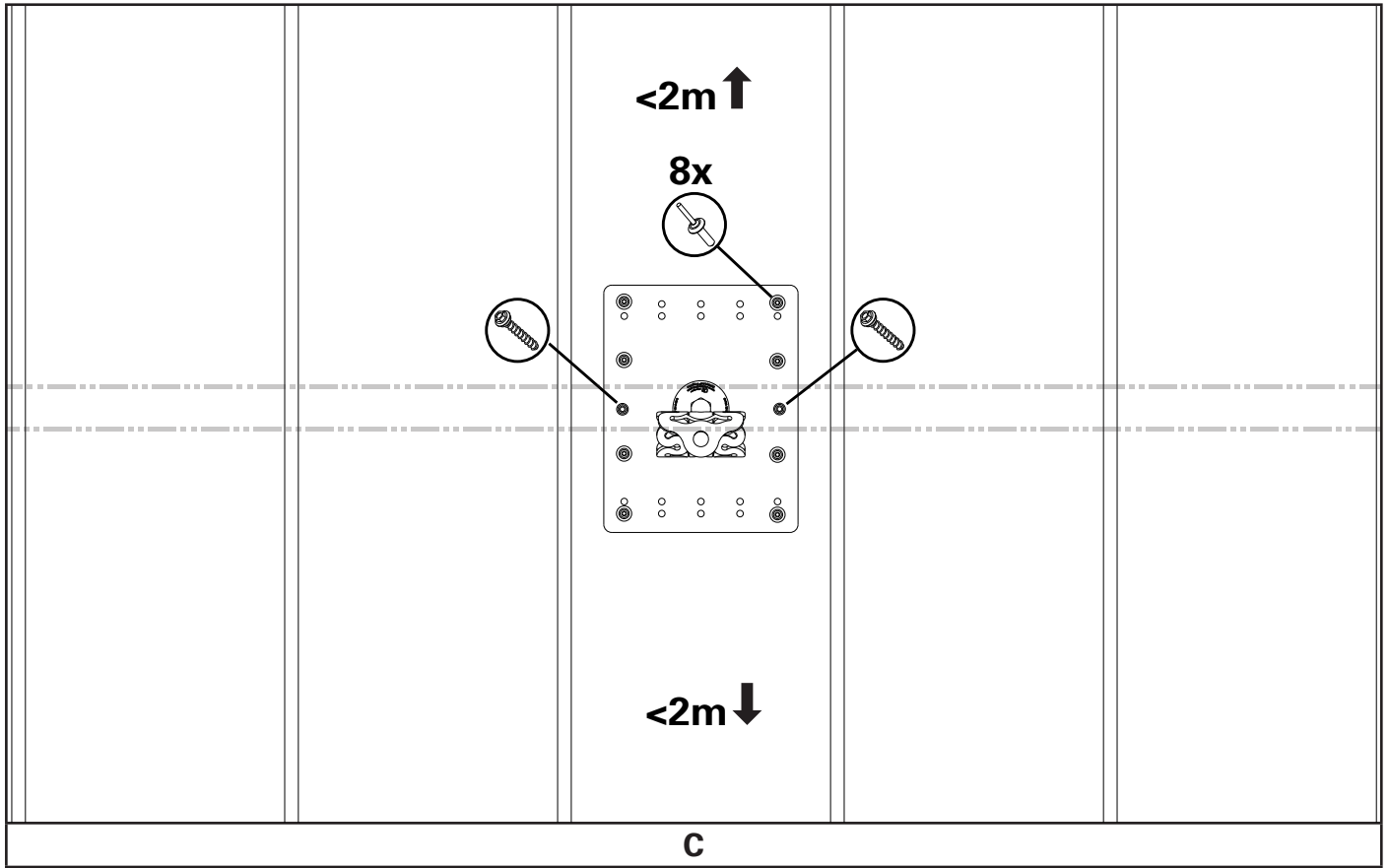

4.16.7 Brownbuilt (Side Fixing)

⚠ Plates shall sit 5mm clear of the top of the roof sheeting.

⚠ All rivets shall penetrate 2 layers of roof sheeting.

⚠ Internal dimension: minimum 165mm, maximum 240mm

A If the plate is to be installed more than 2m from any edge, the plate can be installed with 12 rivets through the crest as shown.

B If the plate is to be installed within 2m of an edge, four fixings shall be installed as shown, through the sheet, into the structure, between the plate and the edge. This must be done for each edge within 2m of the plate. The four fixings can be;

I Screws into the pan of the sheet

II Rivets into the pan of the sheet

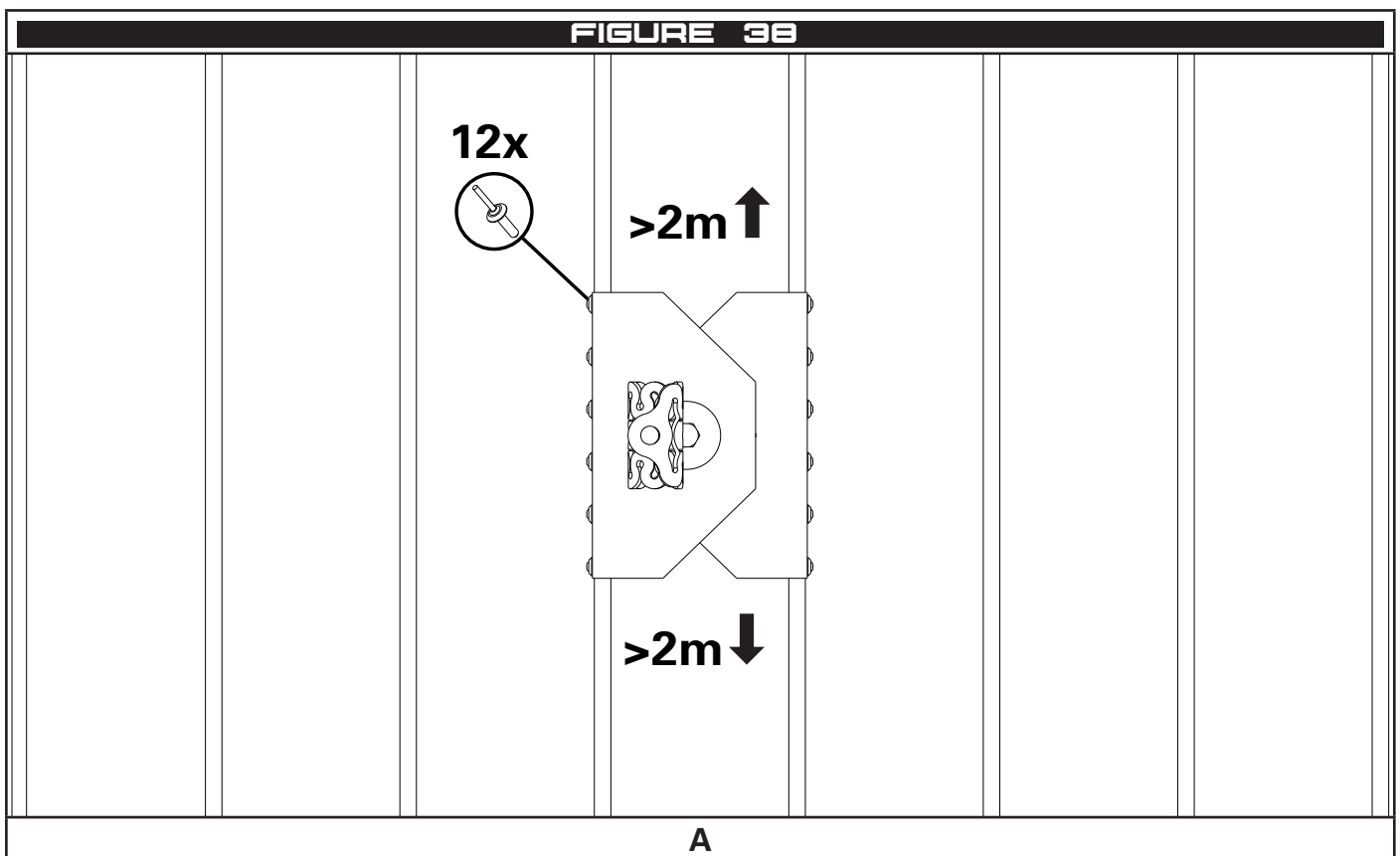

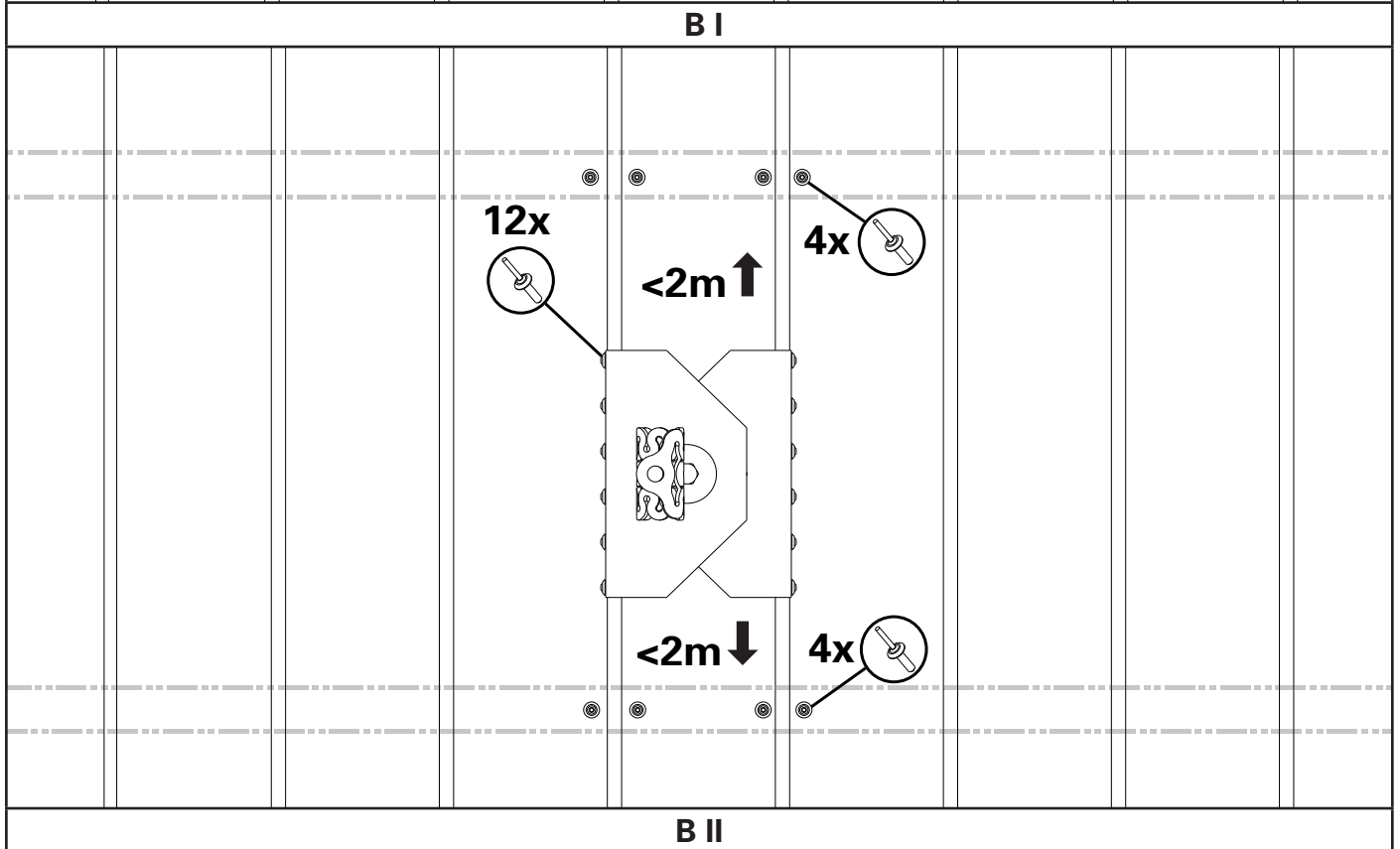
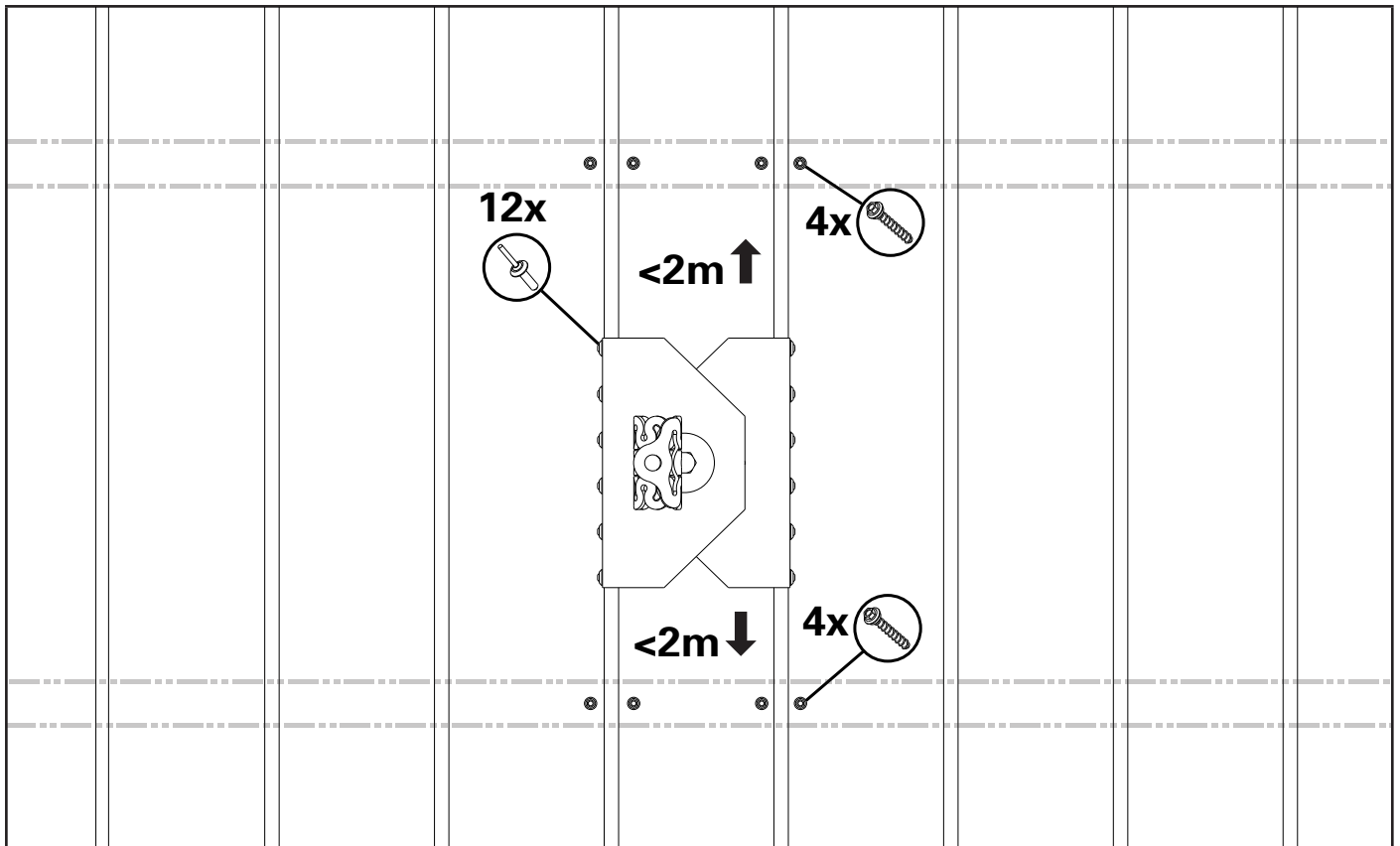

4.16.8 Brownbuilt (Top Fixing)

⚠ Plates shall sit 5mm clear of the top of the roof sheeting.

⚠ All rivets shall penetrate 2 layers of roof sheeting.

⚠ Internal dimension: minimum 165mm, maximum 240mm

A If the plate is to be installed more than 2m from any edge, the plate can be installed with 12 rivets through the crest as shown.

B If the plate is to be installed within 2m of an edge, four fixings shall be installed as shown, through the sheet, into the structure, between the plate and the edge. This must be done for each edge within 2m of the plate. The four fixings can be;

I Screws into the pan of the sheet

II Rivets into the pan of the sheet

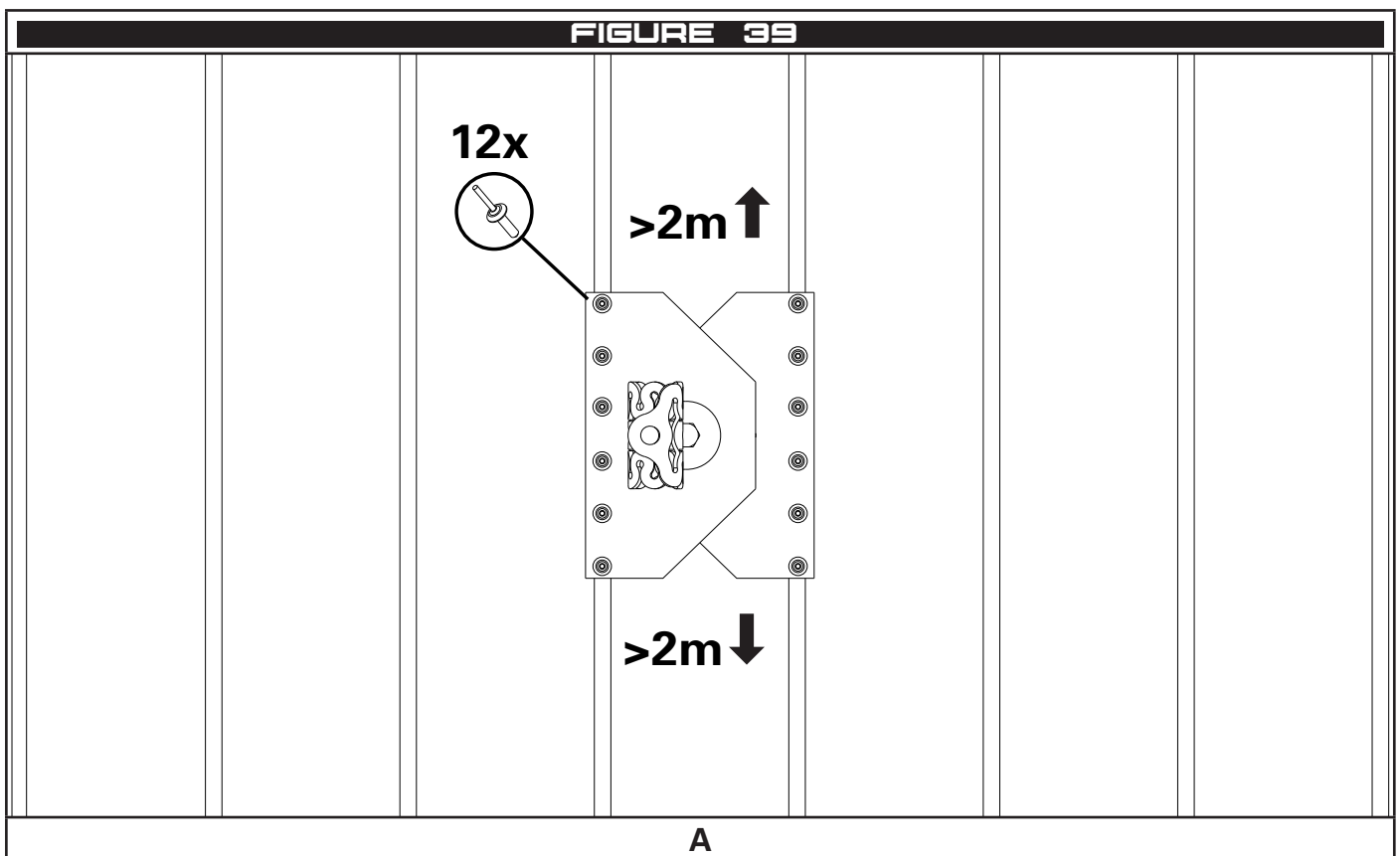

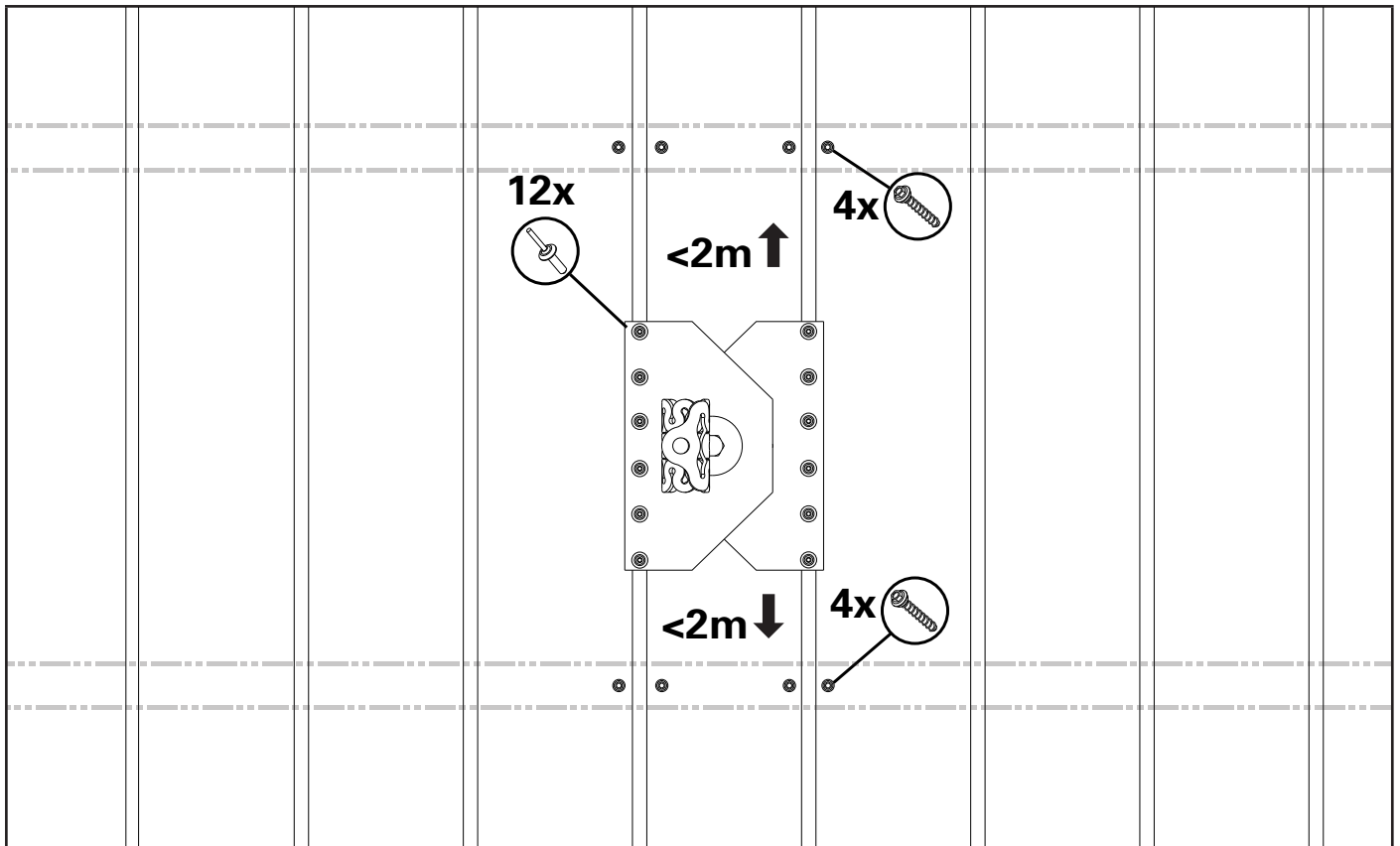

B I

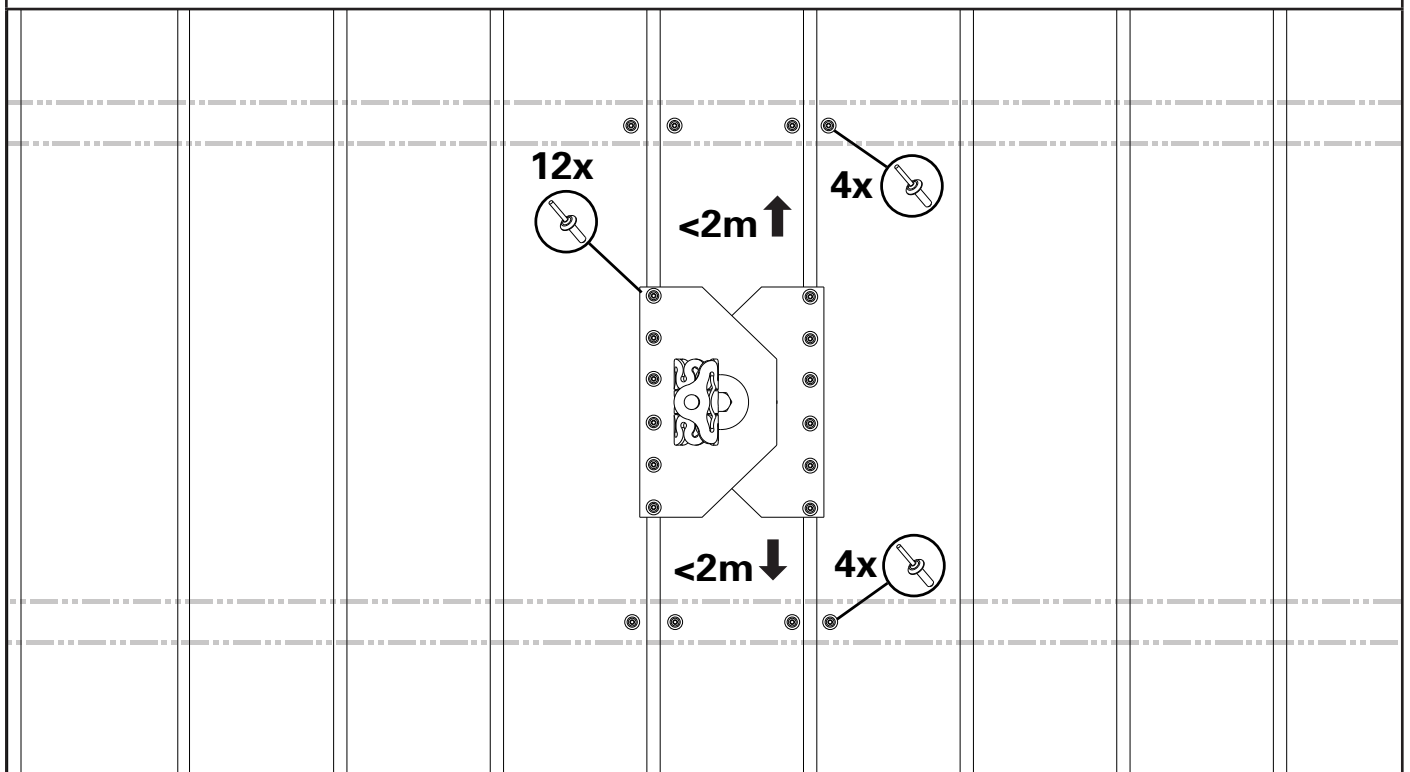

B II

4.16.9 Plywood

A The plate shall be fixed with 16 x14g timber screws 50mm long as shown.

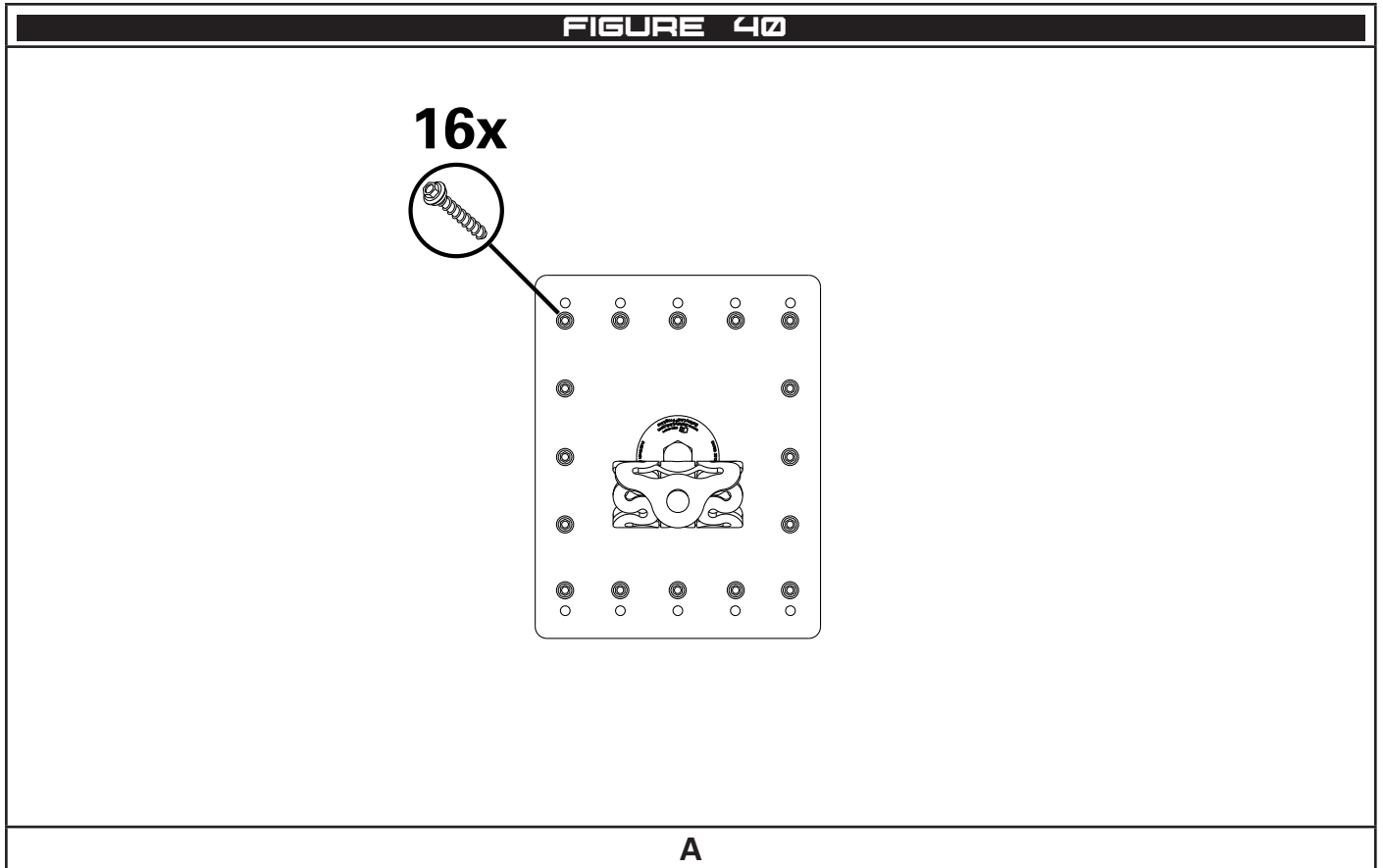

4.16.10 Sandwich Panels (100mm and greater)

- ✓ The span between support can be up to 3m.
- A For roof sheeting that is screwed to the structure, the plate may be installed anywhere on the roof sheet with 10 rivets provided there is a screw line above and below the plate.
- B The plate may also be installed in the screw line with the centre two rivets being replaced by screws.

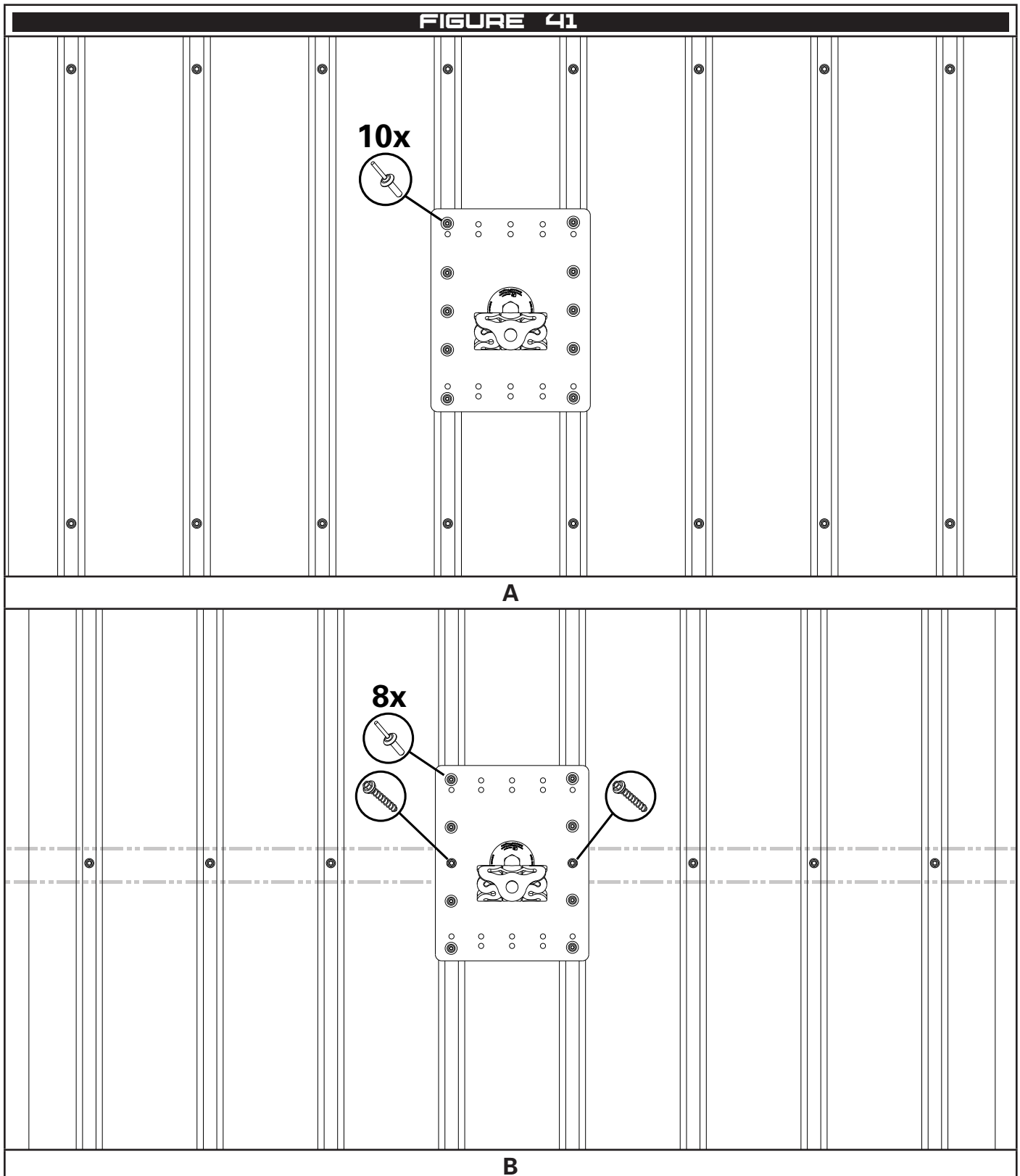

4.17 Membrane

- 1 Mark and drill four 30mm holes in the roof.
- 2 Cut the PVC tube and insulation to suit the thickness of the roof and assemble the toggle bolts through the plate.
- 3 Lower the toggle bolts through the holes and pull up on each bolt to check the toggle has rotated.
- 4 Tighten the bolts to 10Nm.
- 5 Install a suitable membrane cover to match the roof specification.
- 6 Install the bracket with a washer, spring washer and nut. Tighten to 60Nm.

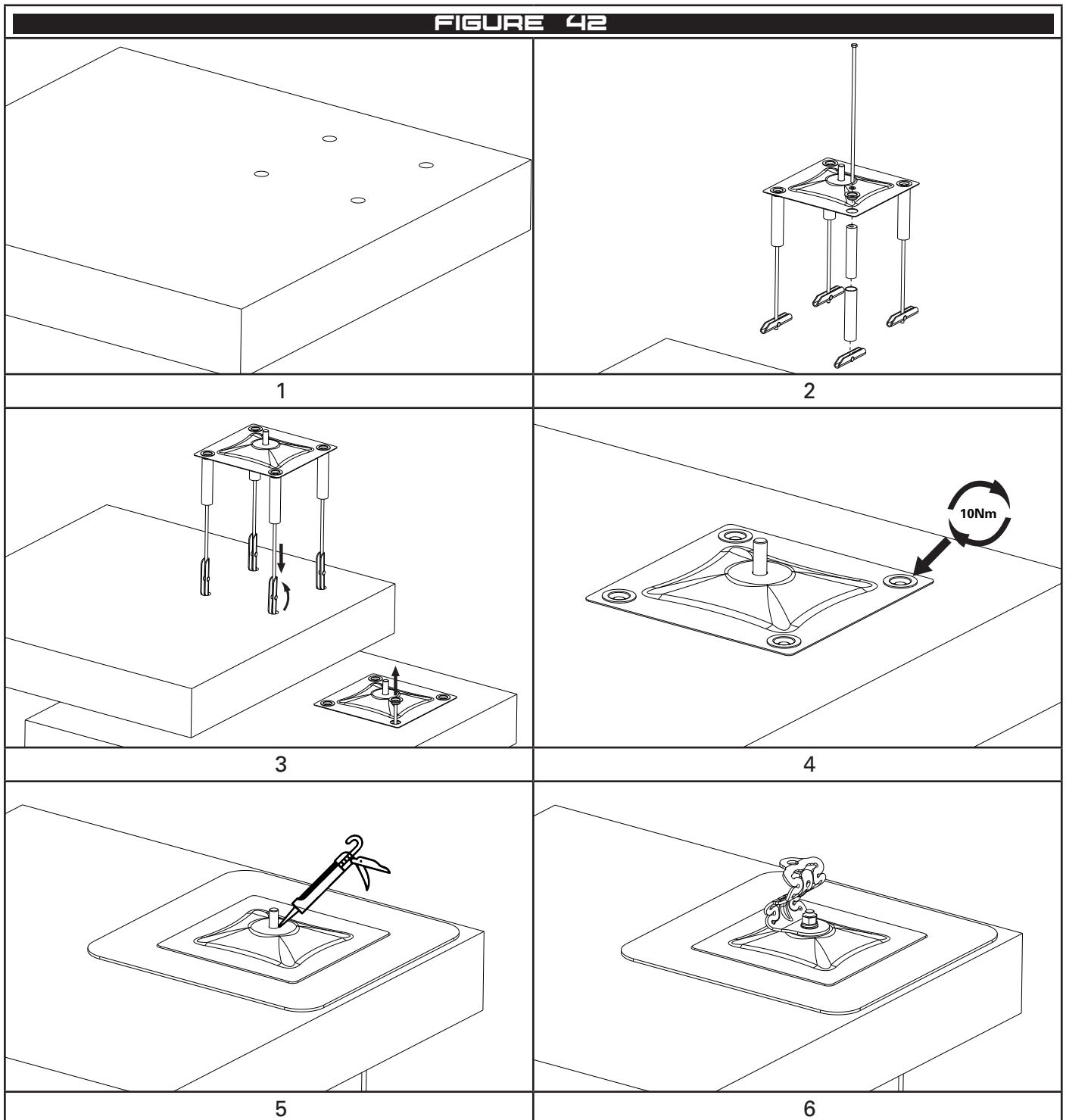

4.18 Clamps

4.18.1 FastFit Clamp SL CLAMP.KL700 (KlipLok 700)

- 1 Assemble the bracket on the plate with the supplied 35mm M16 bolt placing a plastic washer on each side of the plate. (For aluminium plates only, ADV-PLATE-AL-305 & ADV-PLATE-AL-305-SLCLAMP)
- 2 Install the 70mm stainless washer, spring washer and nut. Tighten to 60Nm.
- 3 Drill four $\varnothing 13\text{mm}$ holes in the plate to suit the roof sheeting and install four clamps.
- 4 Install the plate on the roof and tighten all clamps to 20Nm.

⚠ All four clamps shall be located on one sheet. Do not install any clamps on a lap joint.

⚠ If the plate is installed within 2m of an edge, the sheet shall be fixed in accordance with Section 4.16.4 C.

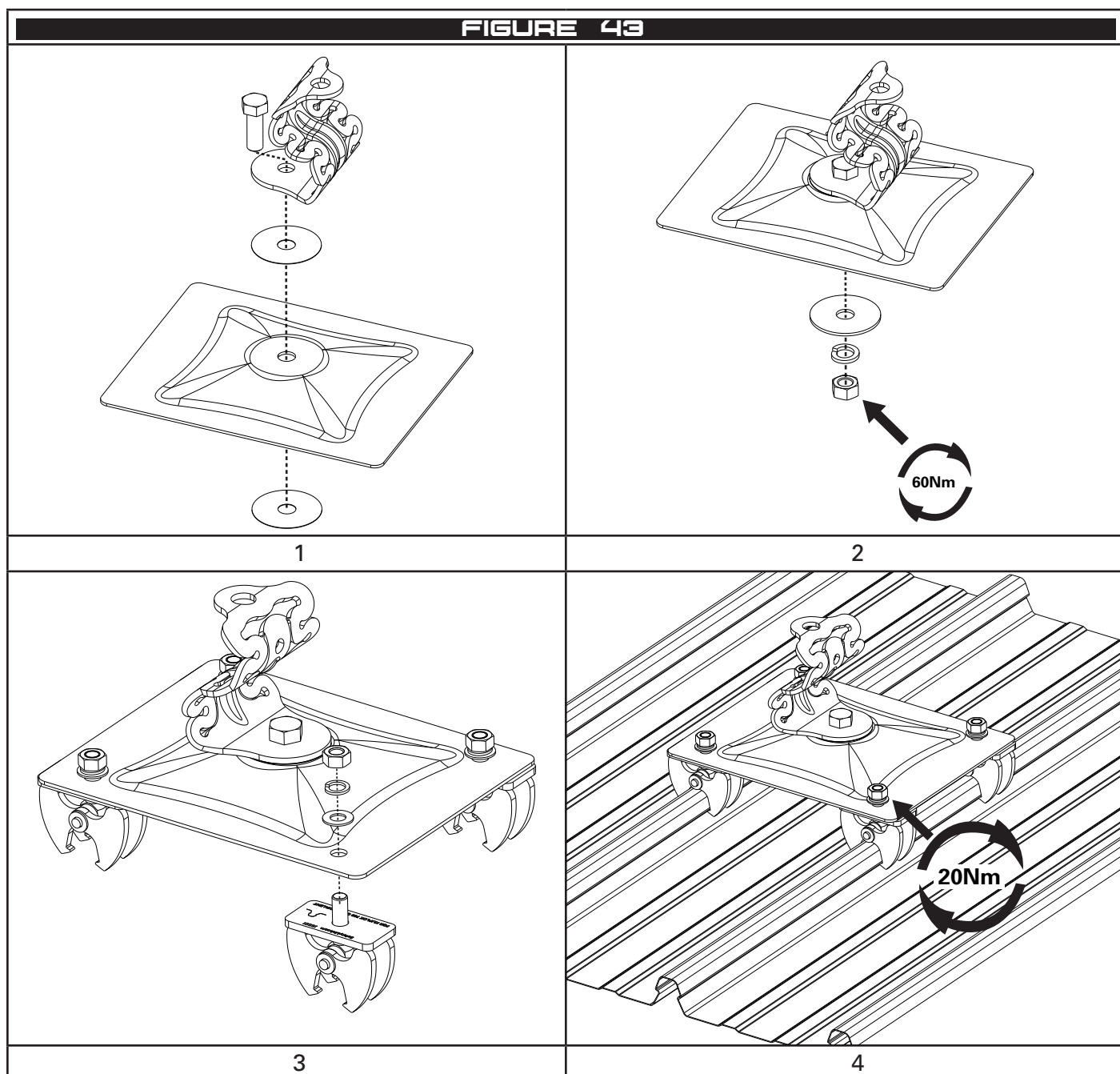

4.18.2 S5 Clamps

- 1 Assemble the bracket on the plate with the supplied 35mm M16 bolt placing a plastic washer on each side of the plate. (For aluminium plates only)
- 2 Install the 70mm stainless washer, spring washer and nut. Tighten to 60Nm.
- 3 Drill four $\varnothing 8.5\text{mm}$ holes in the plate to suit the roof sheeting and install four clamps.
- 4 Install the plate on the roof and tighten all socket screws in each clamp to 15Nm.

⚠ Thread lock adhesive shall be used on all fasteners.

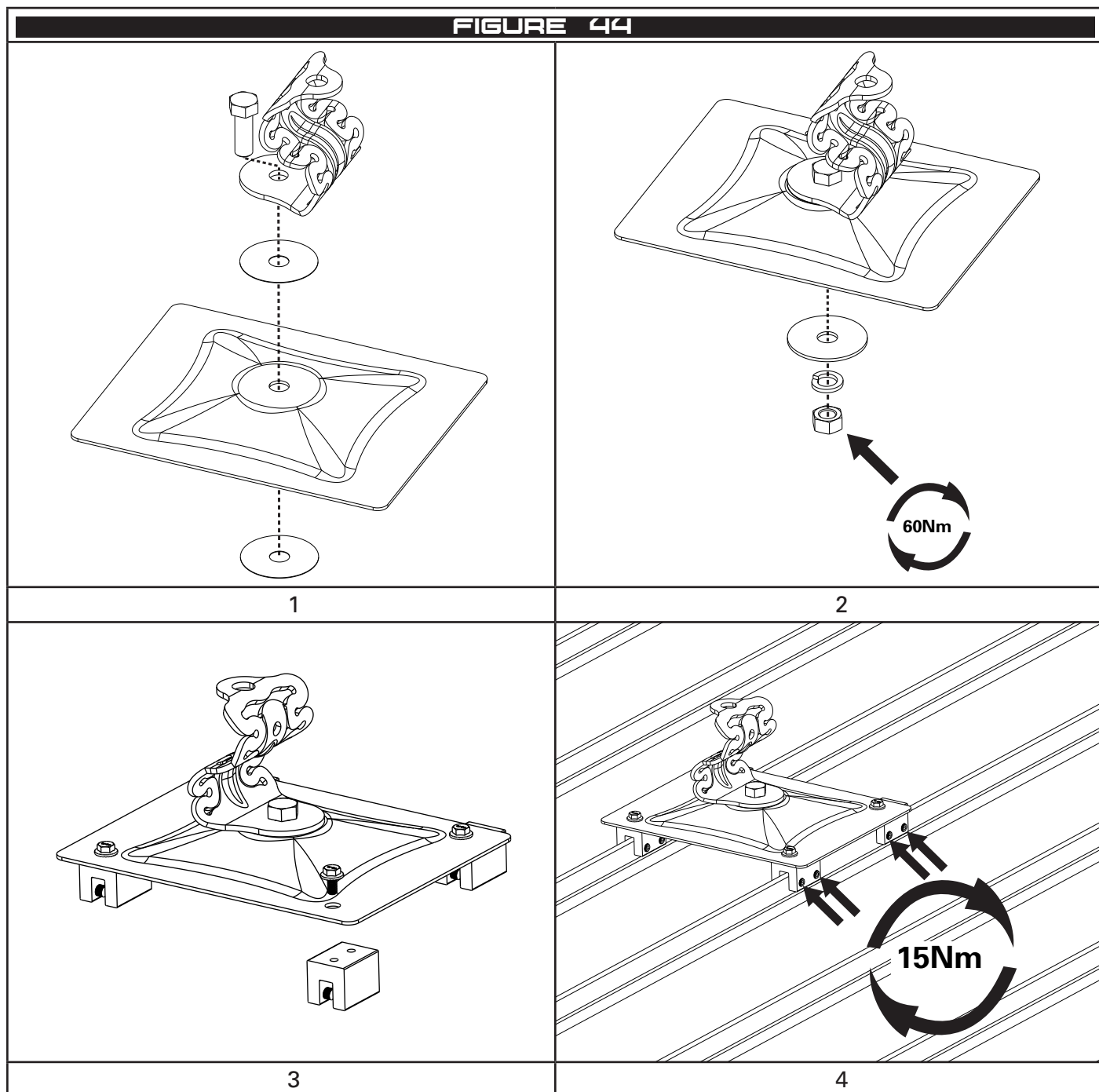

4.18.3 S5-Z Clamps

- 1 Assemble the bracket on the plate with the supplied 35mm M16 bolt placing a plastic washer on each side of the plate. (For aluminium plates only)
- 2 Install the 70mm stainless washer, spring washer and nut. Tighten to 60Nm.
- 3 Drill four $\varnothing 8.5\text{mm}$ holes in the plate to suit the roof sheeting and install four clamps.
- 4 Install the plate on the roof, install the clamp inserts and tighten all socket screws in each clamp.

! *Thread lock adhesive shall be used on all fasteners.*

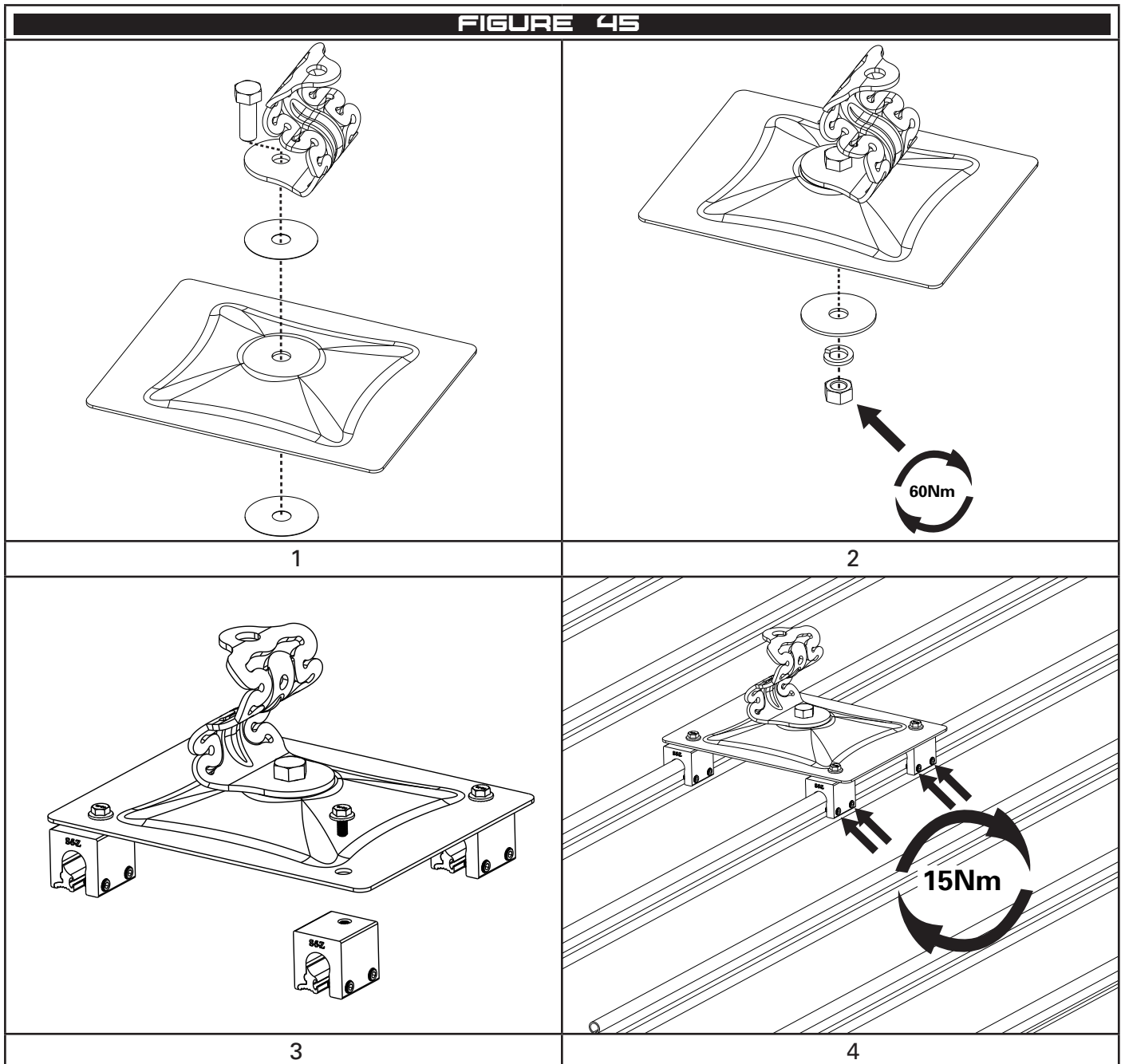

5 Limitations of Use

5.1 Fall Clearance

When planning your fall protection system, it is important to accurately assess all components of your system in order to avoid injury. Figure 46 provides guidance on how to calculate fall clearance. In Figure 46, (A) represents deflection of the anchor (see Section 3.6), (B) represents energy absorber deployment and estimated D-ring slide of the harness (Refer the manufacturer's information), (SF) represents the recommended safety factor of 1m, (FC) represents the total allowable fall clearance. For safe use FC shall always be greater than $D + E + SF$.

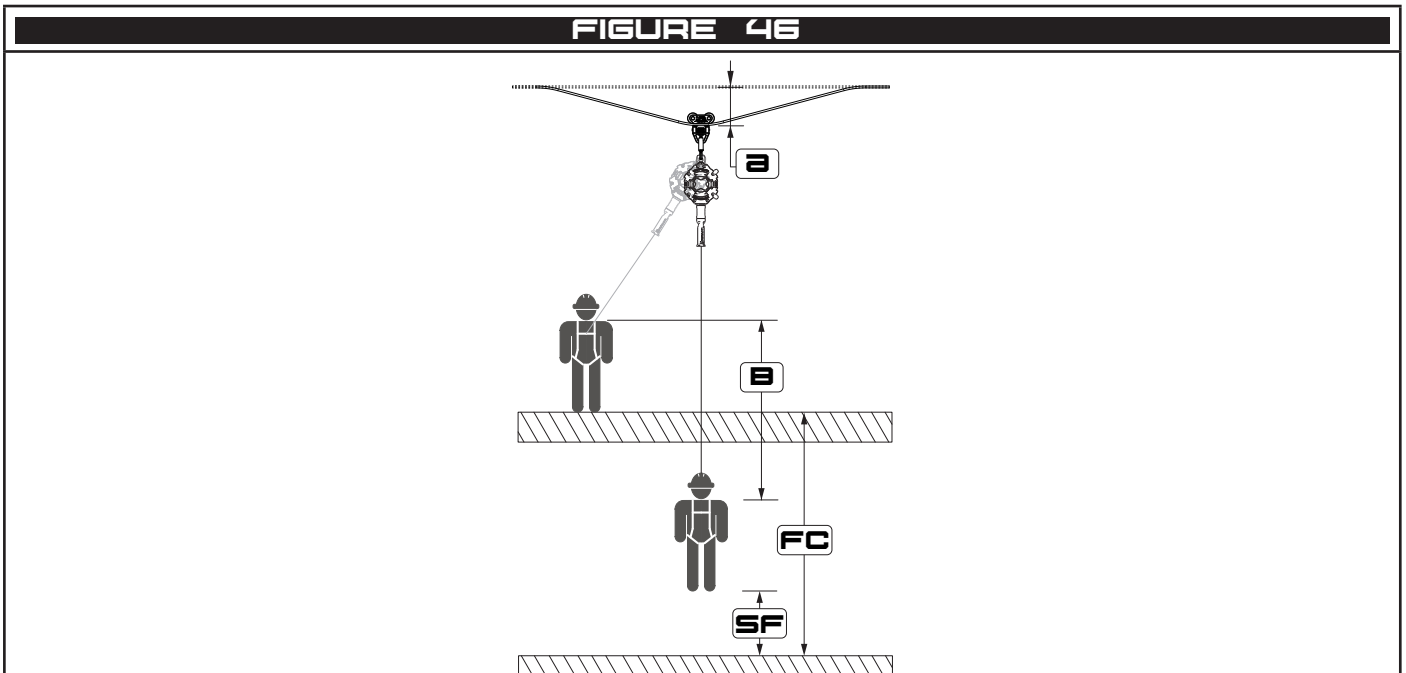

5.2 Swing Fall

Working off centre of a Horizontal Lifeline may cause a swing fall. See Figure 47. Fall protection systems shall be setup in such a way to limit swing fall.

⚠ The force of striking an object during a swing fall may result in serious injury or death.

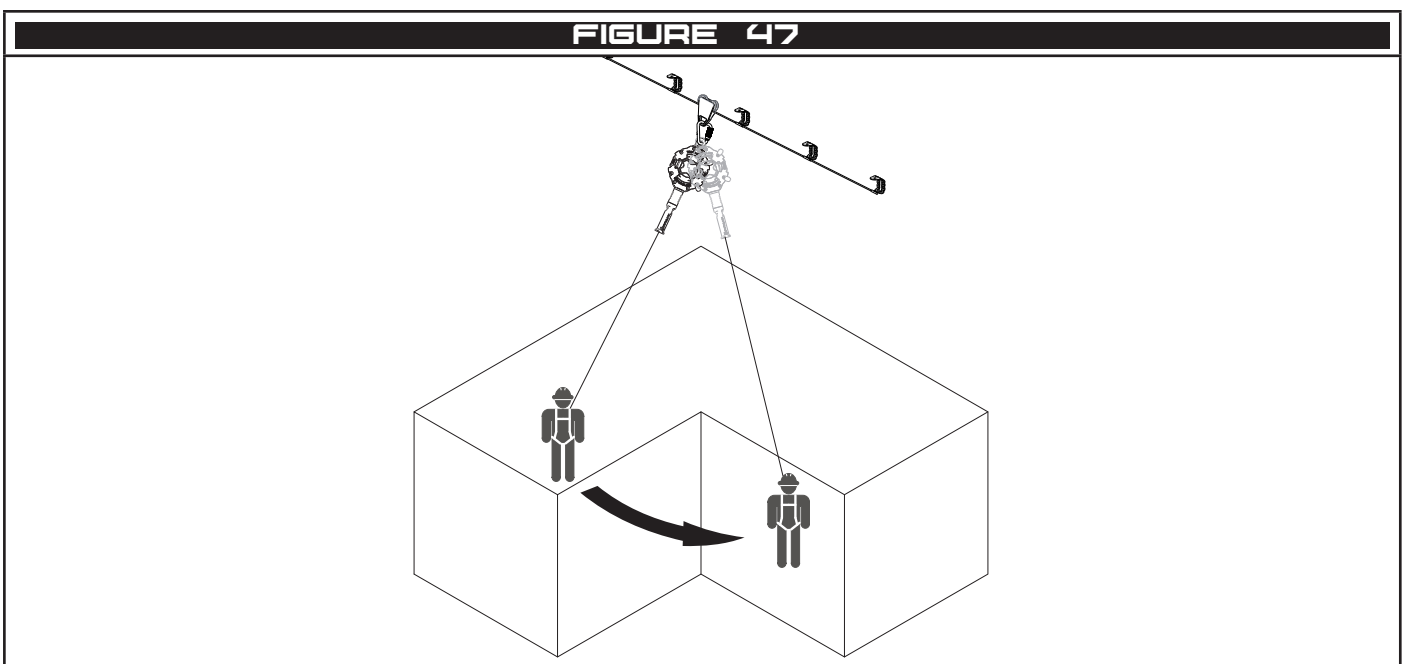

5.3 Hazards

Use of this equipment in the presence of hazards may cause damage to the equipment and/or result in the function of the equipment being impeded. These hazards include but are not limited to; extreme temperature, sharp edges, chemical reagents, electrical conductivity, abrasion, cutting, climatic exposure and rotating or moving machinery.

5.4 Training

It is essential that all users are trained in the proper inspection, setup and use of this equipment. It's the responsibility of the user to ensure they are trained in the correct use of this equipment and understand the limitations of its use.

 ***Incorrect use of this equipment may result in serious injury or death.***

5.5 Rescue

It is the responsibility of the user of this equipment and their employer to have a suitable rescue plan and the ability to implement it at any time during setup and use of this equipment.

5.6 Connection System

Connection systems (SRL, Lanyard, etc.) attached to the FrogLine shall not exceed 8kg.

6 Connections

6.1 Making Connection

Only make compatible connections. Always ensure connectors close and lock correctly before use. Below and Figure 48 are examples of unsuitable connections;

- 1 To an anchor or D-ring which has another connector attached.
- 2 In a position that will apply load to the gate mechanism.
- 3 By passing the connection through the attachment.
- 4 Connecting a connector to another connector.
- 5 Around a structure and back to the lifeline.
- 6 To an attachment that will limit the function of the gate.
- 7 To a location that will not load the connector as designed.

6.2 Compatibility of Connections

Connection made to and with this equipment shall be compatible. Connector shall be compatible shape, size and equivalent rating in order to ensure a compatible connection is made. Incompatible connections may cause loading of the gate mechanism leading to unintentional disengagement. See Figure 49. Connectors shall be compliant with EN362 and auto closing and locking.

! *Making incompatible or unsuitable connection may result in unintentional disengagement of the connector resulting in serious injury or death.*

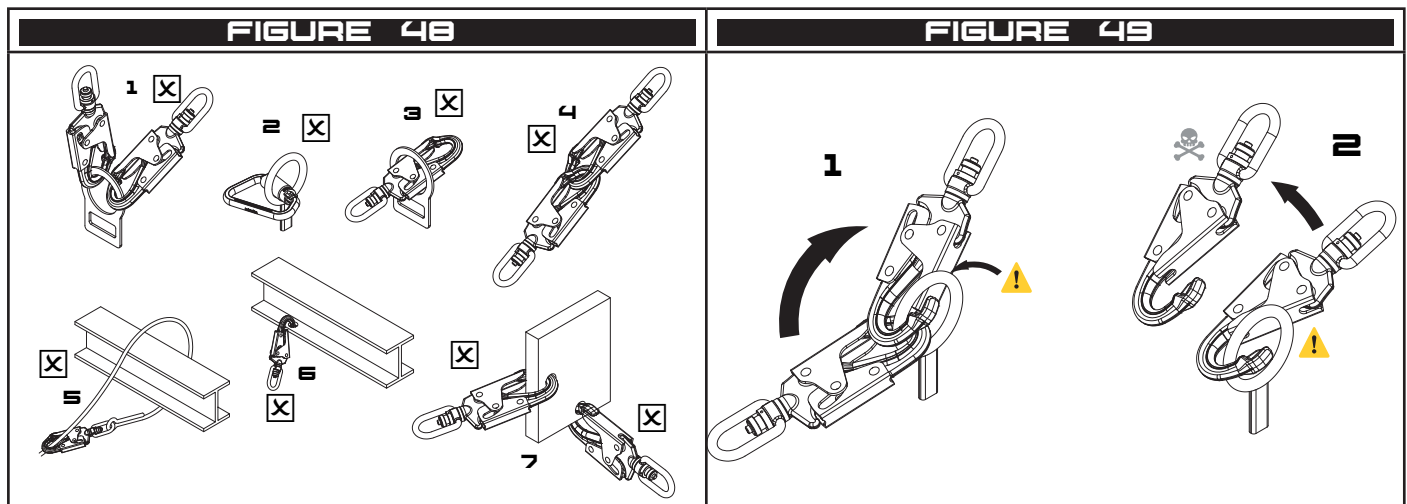

7 Use

7.1 Planning

Before starting work, plan your working at heights and rescue systems by accounting for all hazards present in the work place and allowing for the available fall clearance. Ensure all users are fit, healthy and capable of safely operating this equipment as well as implementing the rescue plan.

⚠ During use always allow for the required fall clearance, swing fall and hazards present in the work place.

7.2 FrogLine Shuttle

- 1 Lift up the small latch.
- 2 Rotate the large gate down and hold open.
- 3 Position the shuttle over the cable.
- 4 Release the gate pieces and check that the latch is fully closed.

The shuttle can be removed from the line by manipulating the latch in the same way.

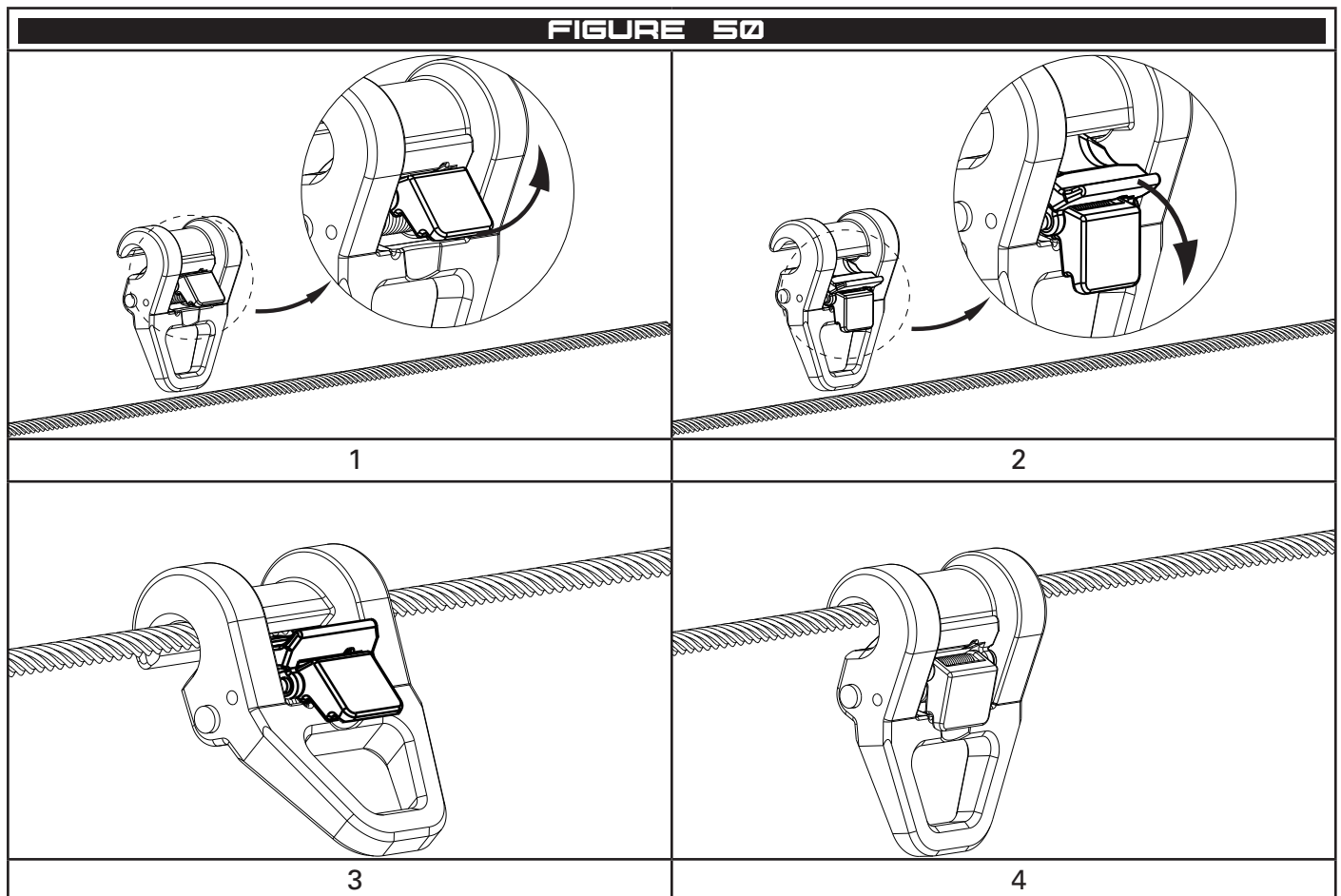

7.3 Overhead Shuttle

- 1 Lift up the small latch.
- 2 Rotate the large gate down and hold open.
- 3 Position the shuttle over the cable.
- 4 Release the gate pieces and check that the latch is fully closed.

The shuttle can be removed from the line by manipulating the latch in the same way.

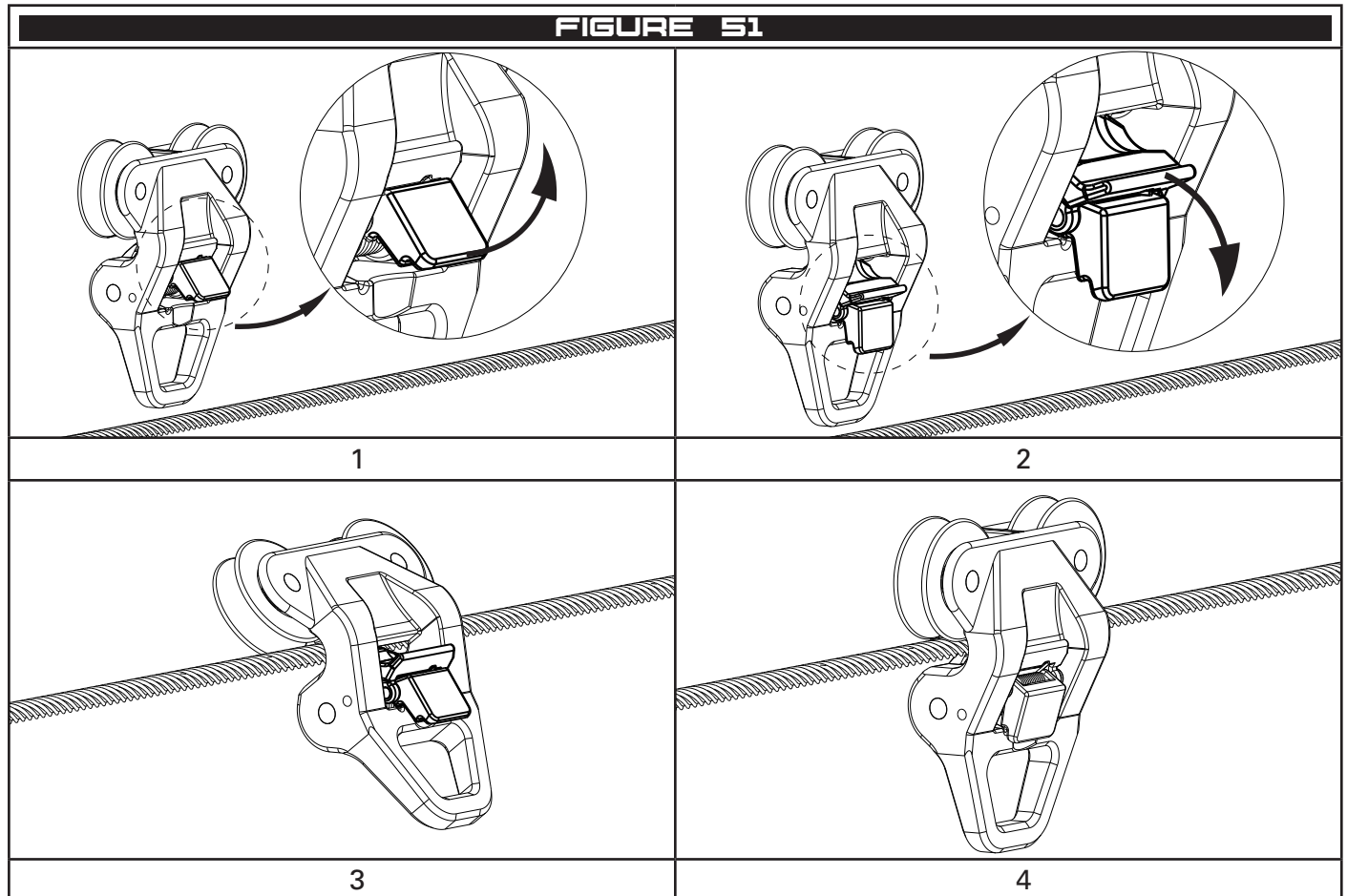

7.4 Shuttle Operation

Each shuttle type has 1 attachment for connecting to the users system.

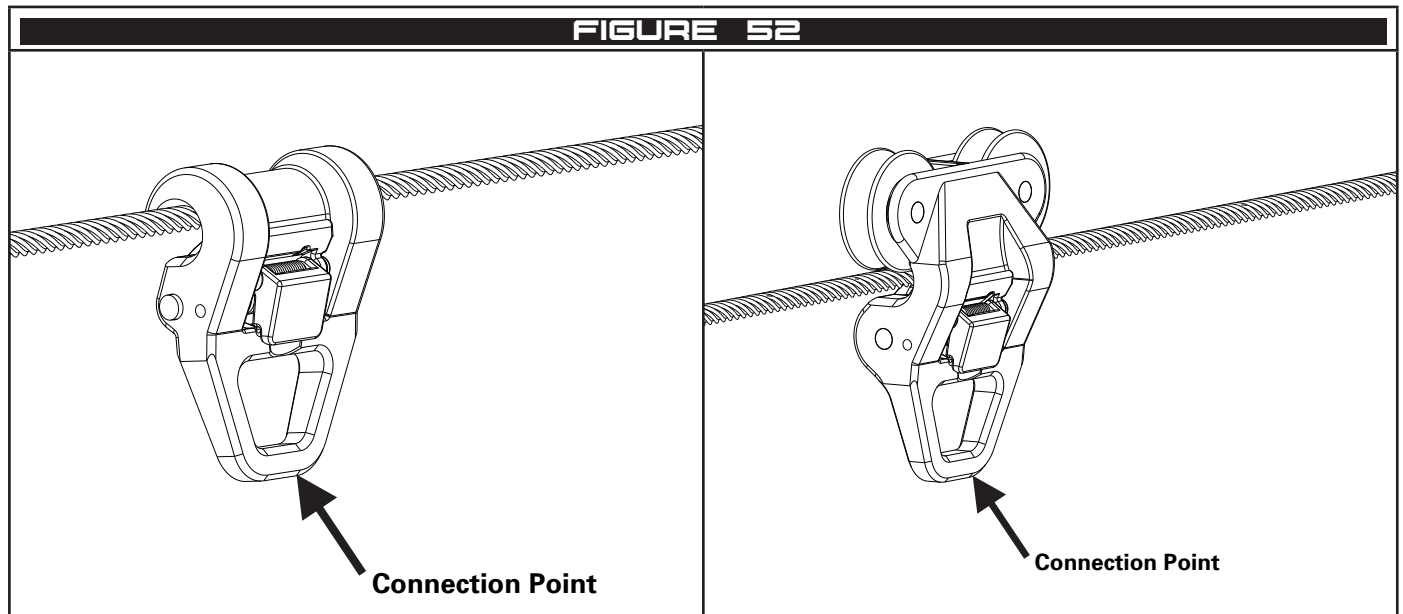

- ⚠ Only attach to the attachment point indicated on the shuttle.**
- ⚠ Do not attach to any other point on the FrogLine.**
- ⚠ Do not attach multiple users a single shuttle.**
- ⚠ Do not exceed the operating range of the shuttle.**
- ⚠ Do not load the shuttle with more than 8kg. This included the weight of SRL's or other heavy connecting systems.**

8 Storage, Transport and Maintenance

8.1 Storage and transport

This equipment shall be stored and transported in a cool, dry environment, away from any hazards and out of direct sunlight.

8.2 Maintenance

The FrogLine system is serviceable only by trained and authorised installers. Contact SafetyLink to find your nearest available installer. The service interval will be determined by the condition in which it is used. Harsher conditions will require more frequent servicing. The equipment may remain in service until it fails an inspection or is involved in a fall.

⚠ Do not attempt to modify or disassemble this product.

8.3 Cleaning

The FrogLine Horizontal Lifeline may be cleaned by the end user periodically to increase service life. After cleaning, the product shall undergo the pre-use inspection.

Clean with a rag and warm water to remove dirt and grit. A mild detergent may be used to remove grease or oils from the product.

⚠ Do not store this product when wet. Allow the product to dry and conduct a pre-use inspection prior to return the item to service.

9 Inspection

9.1 Before and After Use

The FrogLine Horizontal Lifeline shall be inspected before and after each use by the user.

9.2 Competent Person

A competent person shall inspect the system at least every 12 months. Systems installed in harsher conditions will require more frequent inspection. Installations in marine, coastal or other extreme corrosive environments should be inspected at least every 12 months.

9.3 Procedure

FrogLine systems and components shall be inspected as per the below check list.

9.4 Proof Load

Proof loading is for competent person inspections only, concrete fixings that do not extend through the concrete and are not cast in shall be proof loaded to 50% of the design load and held for 30 seconds.

FROGLINE INSPECTION CHECKLIST

Date of Inspection	
Date of Next Inspection	
Inspector	
Position	
Company	

Site Location or Address	
--------------------------	--

General Checklist	Yes/No	Action Taken / Comments
Does the site plan match the components installed?		
Are the components correctly tagged?		
Are all components installed as per the installation handbook?		

Component Inspection	Non Compliant identification number	Action taken / Comments
Warning and compliance sign shall be legible, present and securely fastened. Ensure all installation information is correctly filled out.		

WARNING

↑

ACCESS POINT

↑

Australia 1300 789 545
 International +61 249 641068
www.safetylink.com

THIS SYSTEM MUST:

- BE USED ONLY BY COMPETENT PERSONS.
- BE USED BY PERSONS WITH RELEVANT AUTHORISATION ONLY.
- HAVE ALL SAFETY PROCEDURES COMPLIED WITH AS STATED IN THE CURRENT CODES OF PRACTICE FOR WORKING AT HEIGHTS.
- BE USED WITH A **FULL BODY HARNESS WITH ENERGY ABSORBER** COMPLYING WITH APPROPRIATE LEGISLATION, REGULATIONS AND STANDARDS.
- BE CLOSED IMMEDIATELY IN THE EVENT OF A FALL, DAMAGE OR EXPOSURE TO CHEMICALS. REOPEN UPON REPAIR & RE-CERTIFICATION.
- BE INSPECTED EVERY 12 MONTHS 6 MONTHS

month/	20	year	month/	20	year
month/	20	year	month/	20	year
month/	20	year	month/	20	year
month/	20	year	month/	20	year
month/	20	year	month/	20	year

ANCHOR POINTS - QTY _____

FALL ARREST ABSEILING

LOAD RATING _____ kN

NO. OF PERSONS PER ANCHOR _____

LIFELINE - QTY _____

NO. OF PERSONS PER LINE _____ PER SPAN _____

OTHER _____

LOAD RATING _____ kN



NO. OF PERSONS PER ANCHOR _____



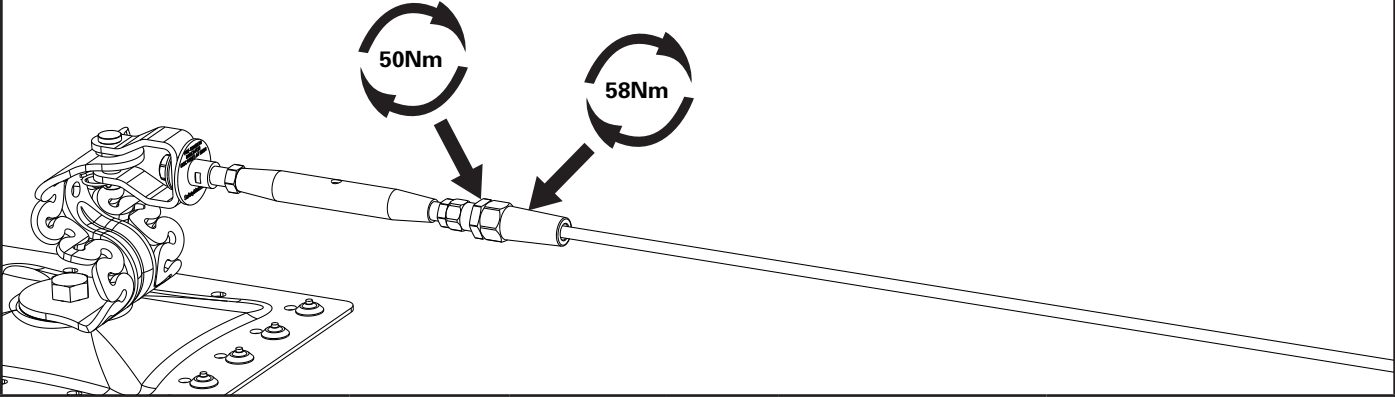
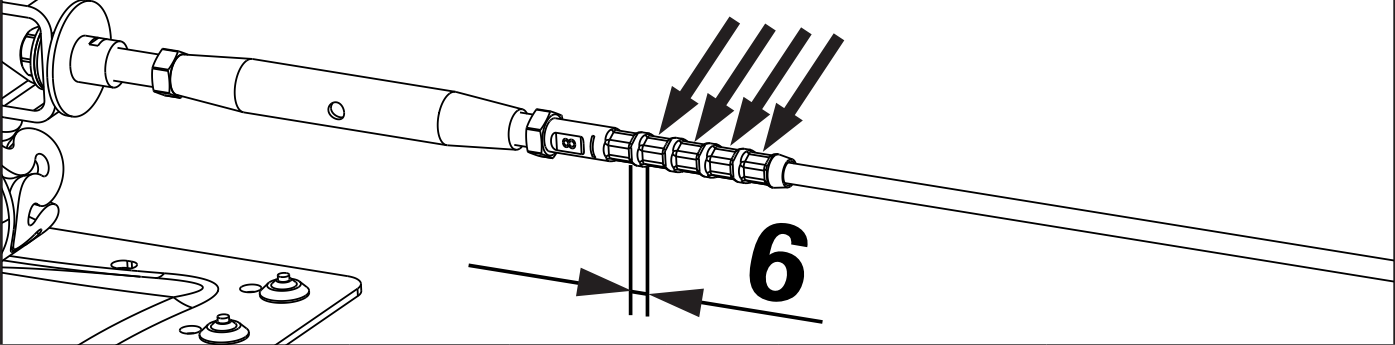

INSTALLER/CERTIFIER: _____

SYSTEM IDENTIFICATION NO: _____

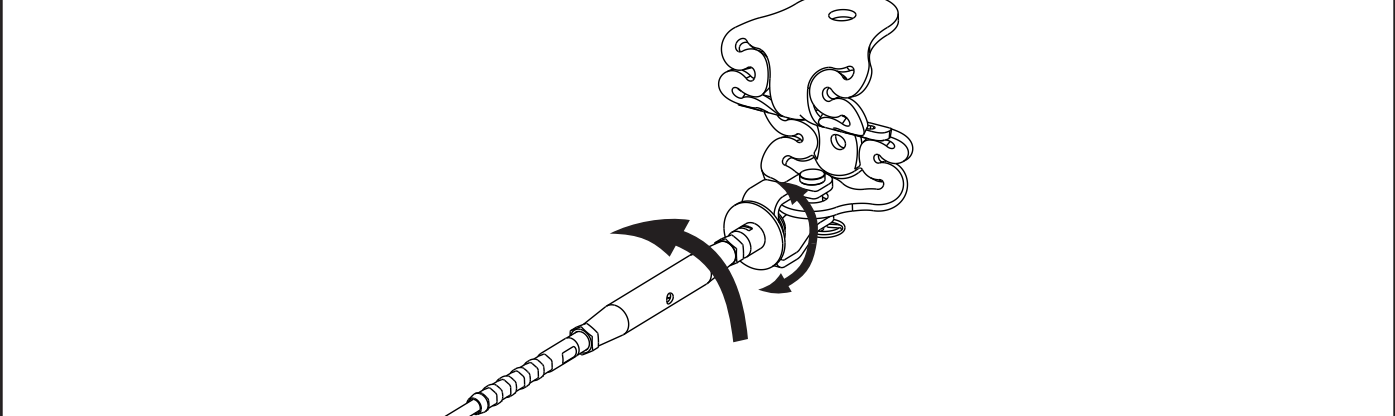
INSTALLED/CERTIFIED DATE: _____

DUE SERVICE DATE: _____

Component Inspection	Non Compliant identification number	Action taken / Comments
<p>Swageless fittings shall be inspected to ensure they have been installed as per Section 4.8.2. Coded Tags shall be fitted to all swageless fittings.</p>		
		
<p>Crimp Fittings shall be inspected to ensure they have been installed as per Section 4.8.1</p>		
		
<p>Inspect the tension Indicator (red disc) is free to rotate under light pressure.</p> <p> Do not over tension.</p>		
		
<p>Inspect the full length of cable to ensure there are no broken strands or wires.</p>		

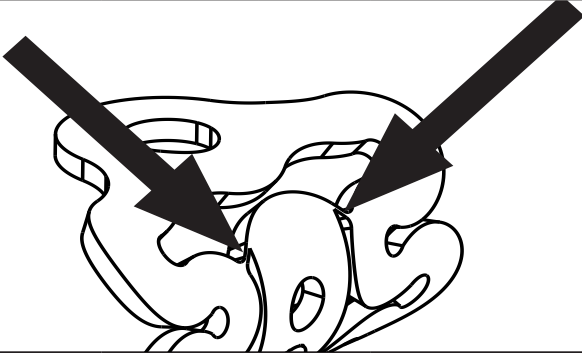
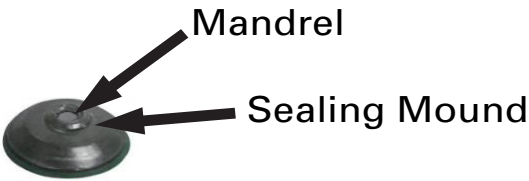
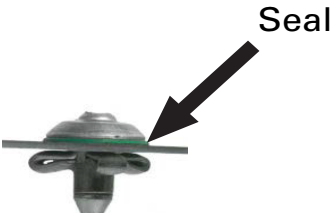
Component Inspection	Non Compliant identification number	Action taken / Comments	
<p>Ends, Intermediates and Corners</p> <p>Inspect the components are not deformed.</p> <p>Check for corrosion, discolouration, cracks, weld defects, distortion and signs of overloading.</p> <p>Check the brackets are no further than 10m apart.</p>			
			
<p>Check the fall indicators are intact.</p>			
			
<p>Check all fasteners are installed and tightened as per Section 4.</p>			
<p>Check the correct number of rivets have been used as per Section 4.16.</p> <p>For each rivet check:</p> <p>a) The mandrel has broken off just below the sealing mound.</p> <p>b) The seal is compressed between the sealing mound and the plate</p>			
			

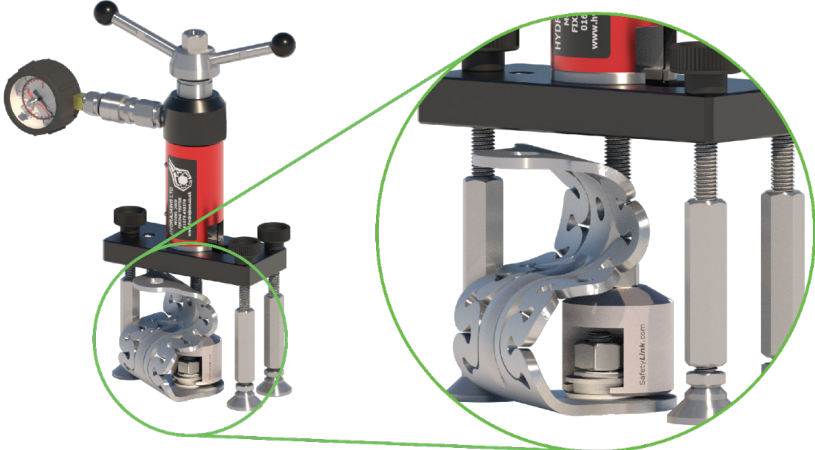
Component Inspection	Non Compliant identification number	Action taken / Comments
<p>Check all bracket for potential water proofing issues. Ensure:</p> <ul style="list-style-type: none"> a) Retro tube installations are correctly sealed with silicon. b) Rivets and screws penetrate the water proofing strips. c) Toggle bolts are installed with silicone sealant. 		
<p>Check surface mounted plates are installed with the appropriate number for rivets and screws for the location as per Section 4.16.</p>		
<p>Check the FastFit Clamps are torqued correctly as per Section 4.18.1.</p>		
<p>Check the S-5 Clamp are torqued correctly as per Section 4.18.2 or 4.18.3.</p>		
<p>Any drilled in fasteners (friction or glued-in) shall be proof loaded to 50% of the design load as per AS/ NZS1891.4</p>		
		
<p>Run the shuttle over the entire line and check for any locations where the shuttle catches or stops on the line.</p>		
<p>Inspect the line angle does not exceed 15° or 25° as per Section 3.1.</p>		

Warranties

EXTRACT: SAFETYLINK PTY LTD STANDARD TERMS AND CONDITIONS

- 1.1 To the extent permitted by law all implied conditions, warranties and undertakings are expressly excluded.
- 1.2 Except as provided in this clause the Company shall not be liable for any loss or damage, whether direct or indirect (including consequential losses or damage) arising out of any breach of contract by the Company or any negligence of the Company, its employees or agents.
- 1.3 Should the Company be liable for a breach of a guarantee, condition or warranty implied by the Australian Consumer Law (not being a guarantee, condition or warranty implied by sections 51, 52 and 53 of that Law) then its liability for a breach of any such condition or warranty express or implied shall be limited, at its option, to any one or more of the following.
- A in case of Goods
- I the replacement of the Goods or the supply of equivalent Goods.
 - II the repair of the goods,
 - III the payment of the cost of replacing the Goods or acquiring equivalent Goods.
 - IV the payment of the cost of having the Goods repaired. Provided that any such Goods are returned to the Company by the Purchaser at the Purchaser's expense.
- B in the case of services
- I the supply of the services again,
 - II the payment of the cost of having the services supplied again.
- 1.4 The Company is not liable for the costs of recovery of the Goods from the field, loss of use of the Goods, loss of time, inconvenience, incidental or consequential loss or damage, nor for any other loss or damage other than as stated above, whether ordinary or exemplary, caused either directly or indirectly by use of the Goods.
- 1.5 The Company warrants that at the time of shipment, Products manufactured by it will be free from defects in material and workmanship. In the absence of a modified written warranty, the Company agrees to making good any such defects by repairing the same or at the Company's option by replacement, for a period of (1) one year from the date of shipment. This limited warranty applies provided that:
- a defects have arising solely from faulty materials or workmanship;
 - b the Products have not received maltreatment, inattention or interference;
 - c the Products have been installed in accordance with the Company's Installation Handbooks using only products supplied by the Company;
 - d accessories used with the Products are manufactured by or approved by the Company
 - e the Products are maintained in accordance with Australian Standard 1891.4 (section 9).
 - f you notify any claim under this warranty to SafetyLink in writing to the address below no later than 14 days after the event or occurrence concerning the produce giving rise to the claim and you pay all costs related to your claim.
- This warranty does not apply to any defects or other malfunctions caused to the Goods by accident, neglect, vandalism, misuse, alteration, modification or unusual physical, environment or electrical stress.
- Please note that the benefits to the purchaser (as a consumer) given by this warranty are in addition to your other rights and remedies under the Australian Consumer Law. Our goods come with guarantees that cannot be excluded under the Australian Consumer Law. You are entitled to a replacement or refund for a major failure and compensation for any other reasonably foreseeable loss or damage. You are also entitled to have the goods repaired or replaced if the goods fail to be of acceptable quality and the failure does not amount to a major failure.
- 1.6 If any goods are not manufactured by the Company, the guarantee of the manufacturer thereof shall be accepted by the Purchaser as the only express warranty given in respect of the goods.
- 1.7 Except as provided in this clause 11, all express and implied warranties, guarantees and conditions under statute or general law as the merchantability, description, quality, suitability or fitness of the Products for any purpose or as to design, assembly, installation, materials or workmanship or otherwise are hereby expressly excluded (to the extent to which they may be excluded by law).

PLEASE SEE SAFETYLINK PTY LTD FULL STANDARD TERMS OF CONDITIONS OF SALE FOR FURTHER REFERENCE.



SafetyLink Pty Ltd | ABN 83 081 777 371 | www.safetylink.com

Head Office: 54 Bonville Ave, Thornton, 2322, NSW, Australia

+64 2 4964 1068 | 1300 789 545

Asia-Pacific/The Americas | info@safetylink.com

Europe/Africa/Middle East | europe.sales@safetylink.com

Northern Europe | uk.sales@safetylink.com